

Chlorella Vulgaris Surface-Mount Photobioreactor with Vision-Based Growth Signature Prediction Optimized by Electromagnetism-Like Mechanism



Ronnie Concepcion II, Michael Jon Alain Saavedra, Jonnel Alejandrino, Maria Gemel Palconit

Abstract: Industrial waste disrupts the natural production of microalgae cultures. Cultivation of microalgae in a controlled environment highly results to biomass with lower contamination necessary as high-valued economic product. In response to the emerging challenges of sustainable energy production, the integration of computational intelligence and biosystems engineering is considered as an open research area. In this study, *Chlorella vulgaris* microalgae were cultivated in BG-11 growth medium on three customized surface-mount light bioreactors that are equipped with digital camera for growth monitoring in terms of accumulated biomass surface area and color reflectance intensity via IoT. Feature-based machine learning models predicted microalgae growth area in terms of water temperature, pH level and turbidity, and light intensity. Microalgae cultures were exposed to combinations of white artificial light source of 2000 ± 1000 lux and water temperature of $27 \pm 5^\circ\text{C}$ using Peltier plate to discriminate biomass growth within a 30-day cultivation period. A total of nine environmental conditions were employed to clearly discriminate the impacts of environmental stressors to microalgae growth. Combined neighborhood component analysis and ReliefF was used to select high impact color features of C, Ye, M, H, and S with biomass area. Electromagnetism-like mechanism optimized-RBNN bested RNN and generalized processing regression with R^2 of 0.985 and RMSE of 6.262. There is also considerable growth in biomass surface area for certain combinations of light intensity and water temperature (2125 ± 625 lux and $28.75 \pm 3.25^\circ\text{C}$), and turbidity and water pH concentrations (3.85 ± 0.15 NTU and 8.025 ± 0.775). However, the photobioreactor with 27°C and 2000 lux exposure is considered having the exact optimum controlled environment condition in cultivating *Chlorella vulgaris* based on the generated growth in biomass surface area of 38.314%. This developed intelligent system is scalable for seamless microalgae production of any strands for renewable energy resource.

Keywords: bioreactor, computational intelligence, computer vision, microalgae

I. INTRODUCTION

The world is dependent on the use fuel to manufacture commodities, power large systems, and activate vehicle motion on the road [1]. Fossil fuel is the most consumed formed of fuel resulting to a great contribution in the vulnerability of the atmosphere to the threat of global climate change due to perilous greenhouse gas (GHG). As the concentration of carbon dioxide (CO₂) emission intensifies due to the production of first generation of biofuel which is drawn from food crops [2], the use of algal biomass has numerous environmentally safe production processes to offer given a land area constraint. Both seawater and freshwater resources are now easily damaged by industrial sector due to improper disposing of chemicals [3-4], with the added malpractices of household communities that are not connected to a local sewage system [5]. Algal biomass is the third generation of biofuel that includes both microalgae and macroalgae resources. This promising approach of utilizing microorganisms to yield high-value products with economic impact is one of the attractive sustaining solutions in maintaining ecological balance and speeding up industrial revolution [6-7]. Biofactories, on the average, produces enough microalgae that is a key indicator for domestication [8]. The challenge of cultivating microalgae is provided with developing an optimal controlled biosystem to have faster production and cleaner biomass. Using artificial intelligence and life cycle analysis, the environmental impact of cultivating microalgae and transforming it to biofuels have been predicted [1,9]. A planning tool for microalgae agriculturist and bio-economist had been developed that outlines the environmental impact and its corresponding profit based on the strain of microalgae to be cultivated and harvesting approach [10]. Microalgae are unicellular microscopic photosynthetic microorganisms or phototrophs that are classified to cyanobacteria or chloroxybacteria and eukaryotic which is similar to green algae or chlorophyta [11]. It can be transformed in energy forms of biodiesel [12], bioethanol [13], biohydrogen [14] and biogas [15]. Biodiesel extracted from microalgae requires the purity of lipids and fatty acids in order to refine good oil.

Revised Manuscript Received on November 24, 2020.

* Correspondence Author

Ronnie Concepcion II*, Electronics and Communications Engineering Department, De La Salle University, Manila, Philippines. Email: ronnie_concepcionii@dlsu.edu.ph

Michael Jon Alain Saavedra, Electronics Engineering Department, University of Perpetual Help System DALTA, Las Piñas City, Philippines. Email: fop.saavedra12@gmail.com

Jonnel Alejandrino, Electronics and Communications Engineering Department, De La Salle University, Manila, Philippines. Email: jonnel_alejandrino@dlsu.edu.ph

Maria Gemel Palconit, Electronics and Communications Engineering Department, De La Salle University, Manila, Philippines. Email: maria_gemel_palconit@dlsu.edu.ph

© The Authors. Published by Blue Eyes Intelligence Engineering and Sciences Publication (BEIESP). This is an open access article under the CC BY-NC-ND license (<http://creativecommons.org/licenses/by-nc-nd/4.0/>)

Chlorella Vulgaris Surface-Mount Photobioreactor with Vision-Based Growth Signature Prediction Optimized by Electromagnetism-Like Mechanism

The Philippines comprises the geographical epicenter of tropical algae diversity in the world as there are abundant microalgae both in marine and freshwater natural habitats such as *Chlorella vulgaris* (*C. vulgaris*), *Spirulina platensis*, *Dunaliellasalina*, *Nannochloropsisculata*, and *Tetraselmis sp.* These strains of microalgae have been characterized to normally depend on environmental parameters such as dissolved oxygen (dO₂) and pH concentration [16-17]. Temperature effect was also analyzed based on the photosynthetic growth and biochemical reactions of *Nannochloropsis oceanica* and it was proven that decrease of temperature to 18°C results to suboptimal production of lipids necessary for extracting biofuel [18].

Aside for being labor intensive, mass culturing of microalgae in outdoor environment is often results to algal crashes. The introduction of indoor mass culture of microalgae using controlled photobioreactors is the currently ideal tactic to generate clean biofuels. In this manner, the quality of biomass is maintained, monitored, and altered by adjusting the pre-harvest factors such as light intensity, temperature, carbon dioxide, pH and water nutrients [19]. A photobioreactor (PBR) is a closed-system bioreactor that houses photoautotrophs and exposes it to light source to generate its own biomass. Outdoor photobioreactors are comparably larger than the one being used in indoor type that is mostly used in mass production of microalgae in the industry scale. Indoor photobioreactors, on the other hand, are mostly used to produce laboratory-grade biomass. There is quite a number of fabricated photobioreactors that are made using transparent horizontal and vertical tubes and cylindrical vessels, raceway pond, flat plate [20], biocoil, and bubble column [21]. These geometrical shapes of photobioreactors have a fallback in analyzing the surface area of microalgae as growth indicator and high developmental cost due to customization of curves to allow proper pressure inside the chamber. The challenge of high cost in lighting system and directional illumination is still present. A centered-light photobioreactor was developed [22] imposing that pattern of illumination and its intensity are highly considerable factors to increase the biomass yield of microalgae. Light management involving triggering on and off of light source [23] and variation of illumination spectrum [24] had been materialized to verify its impact to biomass growth.

Biomass color is directly correlated with the light source spectrum. There is immediate increase in green chromaticity by cultivating *Dunaliella tertiolecta* (*D. tertiolecta*) using red and blue lights after 10 days compared to using white light [25]. Conventionally, microscopic segmentation is the approach for microalgae growth detection [26]. However, the integration of computer vision with computational intelligence offers vast applications of speeding up monitoring, detection, classification, and prediction of microalgae growth signatures [27-28]. Microalgae growth has been monitored by using spectral analysis that defines the different light absorbance of microalgae biomass surface [29], and image processing which uses hue saturation value (HSV) and cyan-magenta-yellow (CMYe) color spaces [30].

Despite of the abovementioned scientific studies in cultivating microalgae for biofuel production, automation using artificial intelligence has not been comprehensively

explored yet. The challenge of distinguishing the harvest maturity and growth signatures of microalgae using bare eyes of the agriculturist is a subjective approach and prone to misclassification. Hence, the integration of computer vision and computational intelligence is an open research in the field of algal technology. In this study, *Chlorella vulgaris* is in-vitro cultivated with combinations of varying artificial photosynthetic light intensity and water temperature to discriminate the best environmental configuration for higher yield. The growth signatures considered are based on the acquired images which are color and phytomorphological features. Surface-mount light photobioreactors equipped with RGB digital camera were developed with IoT-based wireless sensor network for seamless data collection. pH concentration and turbidity level are also monitored in relation to microalgae growth. Optimized feature-based machine learning models were developed to predict microalgae growth.

II. MATERIALS AND METHODS

The developmental architecture for *Chlorella vulgaris* growth signature prediction based on environmental harvest factors using feature-based machine learning models is shown in Fig. 1. In order to mimic the natural environmental stressors, photobioreactors were developed in consideration with light and temperature variations only. Sensors were deployed to quantify environmental stressors. MATLAB R2020a is the only computational intelligence software used in this study. Minitab 19 was used in statistics and Python programming language was used for intelligent electronic system development.

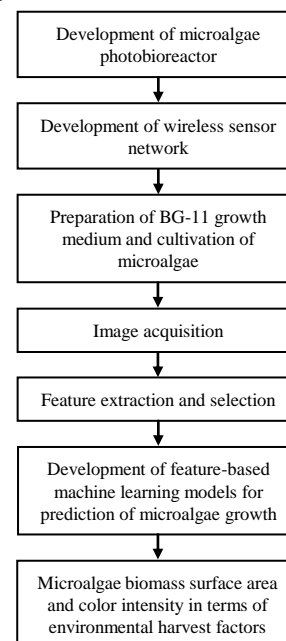

Fig 1. Developmental architecture for chlorella vulgaris growth signature prediction based on environmental harvest factors using feature-based machine learning models

A. Phenotype Description and Artificial Environment Conditions

Chlorella vulgaris is the strain of green microalgae that was cultivated in 30-day life cycle in a phytotron located in Las Piñas City, Philippines with coordinates of 14.4484° N and 120.9867° E. The microalgae culture was obtained from the Aquaculture Department (AQD) of the Southeast Asian Fisheries Development Center (SEAFDEC) in Binangonan, Rizal, Philippines. Photobioreactors were developed to contain *Chlorella vulgaris* culture with varying environmental conditions in terms of light intensity ranging from 1000 to 3000 lux and enclosed chamber water temperature of 22 to 32°C. Shown in Table 1 is the list of photobioreactor environmental test conditions with a total of 9 batches of microalgae cultivations. Each photobioreactor is configured based on the listed environmental conditions every 30 days. Only water temperature and light intensity were considered as controlled environmental stressors that will induce changes on growth rate of the microalgae culture contained on the vessel. The captured microalgae surface image has aspect ratio of 640 x 480 with horizontal and vertical resolutions of 96 dpi and bit depth of 24. There is a total of 864 images collected over a month of cultivation for all the photobioreactors.

Table- I: Environmental Test Conditions for Each Photobioreactor

Test Chamber	Water Temperature (°C)			Light Intensity (lux)
	Cond. 1	Cond. 2	Cond. 3	
PBR 1	22	27	32	1000
PBR 2	27	32	22	2000
PBR 3	32	22	27	3000

B. Photobioreactor Development

Three photobioreactors were constructed to house *Chlorella vulgaris*. By definition, a photobioreactor utilizes light source to allow photosynthesis in the generation of biomass of phototropic microorganisms such as microalgae.

In this study, photobioreactors are constructed using white plastic sheets, with dimensions of 57 cm x 42 cm x 37 cm (Fig. 2). This vessel can handle 80 liters of liquid. Artificial photosynthetic lighting was employed using T8 white light spectrum LED that is placed at the chamber cover. It was carefully considered that the whole water surface area is benefited with this light source. As light intensity is directly proportional to its power, a metal oxide semiconductor field effect transistor (MOSFET) driver circuit enhanced by pulse width modulation (PWM) was constructed to calibrate the light source from 3 to 7 watts. To control the water temperature of the bioreactor, a tandem configuration of two Peltier device which is composed of bismuth telluride (Bi₂Te₃) and tellurium (Te), was placed on the sidewall of the photobioreactor. It exhibits thermoelectric principle by generating heat with the aid of external power source. This configuration increases the efficiency of Peltier plate to provide lower temperature despite of high ambient temperature. Each Peltier plate is rated 150 watts. Relay circuit is constructed for the controls of Peltier activation. Aerator was also placed to promote carbon dioxide

dissolution on to the aqueous system.

One mote per photobioreactor is configured to monitor the environmental conditions. It is constructed by integrating TSL2561 light sensor, DS18B20 weather-proof temperature sensor, SE0198 turbidity sensor and Gravity pH sensor with Arduino Mega as the processing core in enabling the array of sensors (Fig. 3). The Arduino Mega microcontroller is then connected with Raspberry Pi 3 Model B+ for wireless transmission of acquired sensor data.

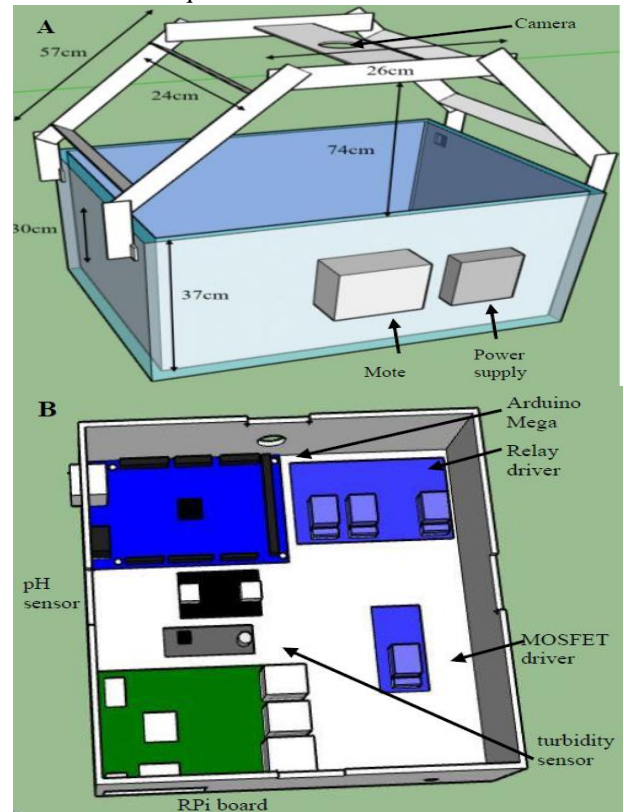

Fig 2. Design of (a) photobioreactor test platform and (b) the component placement of a single mote

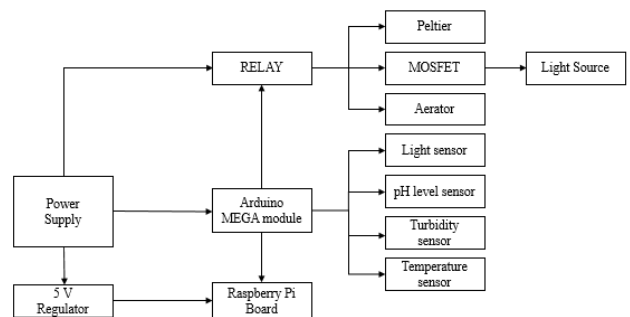

Fig 3. System block diagram of a single mote placed on a photobioreactor to control light intensity and temperature configuration and monitor environmental stressors

To render data integrity on the acquisition module, each sensor was subjected to calibration. pH sensor underwent three-point calibration where each sensor probe is properly submerged to containers with pH 7, 4, and 10 calibration solution, resembling neutral, acidic, and basic concentrations, separately for two minutes.



Chlorella Vulgaris Surface-Mount Photobioreactor with Vision-Based Growth Signature Prediction Optimized by Electromagnetism-Like Mechanism

The sensor probe is rinsed with distilled water (dH₂O) and dried with paper towel before contacting with another test solution. DS18B20 temperature sensor is corrected using two-point calibration technique by subjecting the sensor metallic probes to boiling and freezing point conditions [31]. TSL2561 luminosity sensor is also corrected using two-point calibration technique by subjecting to laboratory light source with known luminosity and black box. Turbidity sensor is subjected to zero nephelometric test with agitations and signal-averaging. All sensor calibrations were done with room temperature ranging from 24 to 26 °C. The collected calibration data was used to generate the regression equations for each sensor and were embedded in Arduino Mega microcontroller. Overall, the developed photobioreactor is movable due to built-in wheels beneath the vessel itself and compact placements of electronic components. Single photobioreactor is considered an independent system, thus, can be placed to other place with no dependency with other photobioreactors because it has its own intelligent system to control in range the water temperature and light intensity needed for photosynthetic production.

C. Wireless Sensor Network Development

A self-configured data-centric wireless sensor network (WSN) composed of three client motes deployed in physical environment monitoring, one sink node, WiFi router and cloud connectivity and user machine is developed in this study (Fig. 4). It is used to monitor and record physical observations of environmental pre-harvest factors of *Chlorella vulgaris* microalgae. Motes were connected in star topology to the sink node. IP Logitech cameras were directly connected to the USB adapter of Raspberry Pi microcontroller and to the cloud via Internet capability. To ensure data storage, data duplication is manifested on the system by storing sensor data both in the Google cloud and individual Raspberry Pi local memory card. Time scheduling of hourly acquisition is employed. The collected images and data sensors were purged from the cloud storage using file transfer protocol (FTP) and secured control protocol (SCP) down to the local user machine in comma separated variable (.csv) file format. The data file is configured to record series of data array composed of 5 data elements with the following consecutive placement: {data acquisition timestamp, water temperature, light intensity, pH concentration, turbidity level}. No transmission delays were experienced due to close proximity of motes with sink node and WiFi router.

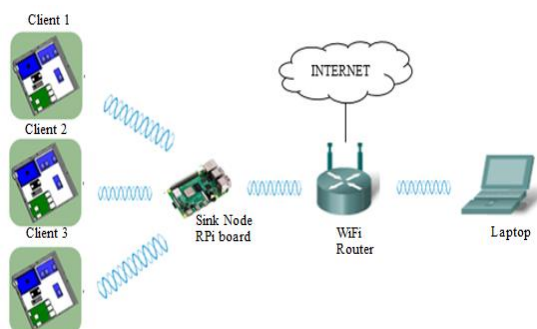

Fig 3. Wireless sensor network architecture with sink node for IoT

D. Growth Medium Preparation and Microalgae Cultivation

Water impurities due to industrial and household wastes adversely impacts the generation of biofuel from microalgae with good quality. With this very reason, there is a need to formulate artificial saltwater with no impurities. The preparation of BG-11 growth medium was done in a laboratory with analytical-grade chemicals. Shown in Table 2 is the composition of BG-11 growth medium and Table 3 presents the BG-11 stocks composition. BG-11 stock 3 is primarily composed of ferric ammonium citrate ((NH₄)₅[Fe(C₆H₄O₇)₂]) and partially of ethylenediaminetetraacetic acid disodium salt (EDTA 2Na). This medium results to no impurities yielding better quality of microalgae. In this study, 30 liters of distilled water and 6 liters of BG-11 growth medium were mixed and set as the primary solvent for each photobioreactor vessel.

BG-11 growth stocks 1, 2, 3 and 4 were first prepared before making the growth medium. These stocks were mixed with deionized water using laboratory glass bottles based on the measurement listed on Tables 2 and 3, and then mixed with other BG-11 growth medium components using glass rod that resulted to pure artificial saltwater.

Table- II: BG-11 Growth Medium Compositions

Component	Amount (L ⁻¹ of total solution volume)
NaNO ₃	1.5 g
K ₂ HPO ₄	0.04 g
MgSO ₄ ·7H ₂ O	0.075 g
Citric Acid	0.006 g
Stock 1	1 mL
Stock 2	1 mL
Stock 3	1 mL
Stock 4	1 mL

Table- III: BG-11 Stocks Composition

BG-11 Stock	Component	Amount (L ⁻¹ of total solution volume)
1	NaNO ₃	2 g
2	CaCl ₂ ·2H ₂ O	3.6 g
3	Ferric ammonium citrate	0.6 g
	EDTA 2Na	0.1 g
4 Part A	H ₃ BO ₃	0.572 g
	MnCl ₂ ·4H ₂ O	0.362 g
4 Part B	ZnSO ₄ ·7H ₂ O	0.0444 g
4 Part C	Na ₂ MoO ₄ ·2H ₂ O	0.078 g
4 Part D	CuSO ₄ ·5H ₂ O	0.0158 g

E. Feature Extraction and Selection

Spectro-morphological microalgae growth signatures were extracted to differentiate daily growth with the impact of photosynthetic light intensity and water temperature level inside the photobioreactor. Color features were extracted from the following visible color spectrums: red, green, and blue (RGB), hue, saturation, and value (HSV), cyan, magenta and yellow (CMY), lumina, blue-difference, and red-difference (YCbCr), and lightness, green-to-red, blue-to-yellow (CIELab).



Using 10,000 superpixels, which is based on simple linear iterative clustering (SLIC) algorithm and K-means clustering [4, 32], it was superimposed on to the raw microalgae surface images to segment non-vegetative pixels from vegetative which is microalgae and region of interest (ROI) in this application. The phytomorphological area of microalgae was computed using region properties of the annotated image.

There is a total of 16 image-based features considered as growth signatures for microalgae being cultivated where 15 of these are color elements. Using human bare eyes often results to subjective classification on the maturity of microalgae even with presence of artificial photosynthetic light, thus computer vision-aided color extraction is necessary. Hybrid neighborhood component analysis (NCA) and ReliefF algorithms were used for feature selection of abiotic environmental stressors of water temperature, pH, turbidity, and light intensity, and spectral signatures based on its variation impact to the extracted microalgae surface area (Fig. 5). NCA is configured with limited-memory Broyden-Fletcher-Goldfarb-Shanno algorithm as its solver, Hessian history size of 15 and line search method of weak Wolfe. By following the results of hybrid NCA-ReliefF, water temperature and pH concentration inside the photobioreactor have the greatest relevance to microalgae surface area among other abiotic environmental stressors. Conversely, color components of yellow, magenta, hue, cyan, and saturation resolves on providing highest correlation with microalgae surface area.

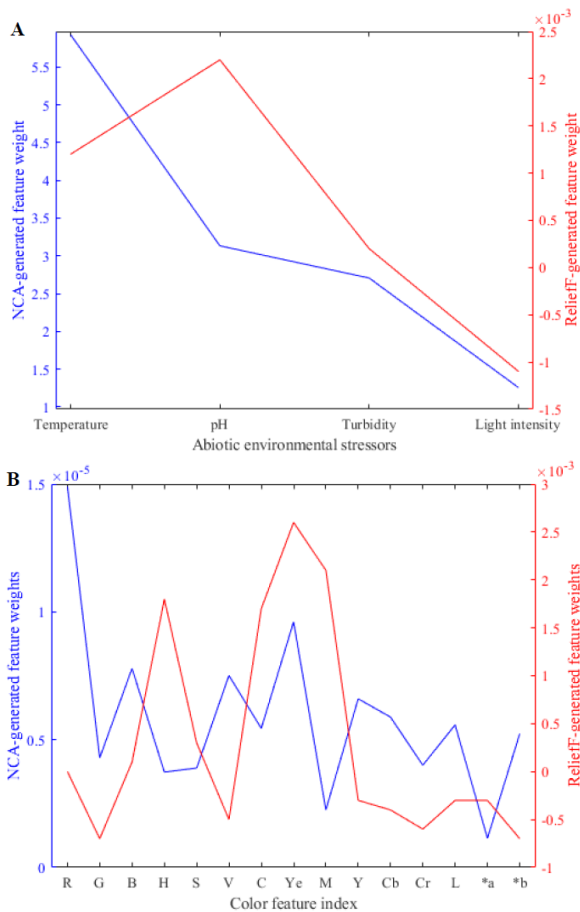

Fig 5. Feature selection of (a) abiotic environmental stressors and (b) biomass spectral signatures based on its relevance to microalgae surface area using neighborhood component analysis and ReliefF

F. Development of Feature-Based Machine Learning Models for Prediction of Microalgae Growth

The extracted features from the previous step were utilized in developing feature-based machine learning models for prediction of microalgae growth in terms of its surface area as captured by the camera. In this study, radial basis neural network (RBNN), recurrent neural network (RNN) and generalized processing regression (GPR) were configured to generate prediction of surface area based on environmental stressors and color signatures, separately. RBNN was optimized by using electromagnetism-like mechanism (EM) which is a physics-inspired metaheuristic algorithm materializing the principle of attraction and repulsion of charged particles in electromagnetic field [28]. In this study, it starts with initializing the 100 charged particles as uniformly distributed along the two-dimensional hypercube of electromagnetic field. Then, the electromagnetic activity of a sampled charged particle is tested, and its corresponding objective function value (y) is calculated with x as the spread factor value in constructing the RBNN architecture (1). The explored electromagnetic hypercube dimension ranges from 1 to 10 (Fig. 6a) and the maximum feasible step length ranges from 0 to 1 (Fig. 6b). New charged particle is labeled as best particle when the current charged particle exhibits lower objective function value. The EM optimization of RBNN terminates after 500 iterations with optimum convergence. It is exhibited with unchanging current best charged particle resembling the spread factor value of 14. It is noticeable that spread factor value dominantly follows the nature of the objective function value on a certain scale increase (Fig. 6c). RNN was optimized by constructing its architecture with 250-150-50 artificial neurons configuration on the hidden layer. On the other hand, GPR was optimized using Bayesian algorithm as solver, squared exponential for kernel function, constant basis function with beta of 24.8520 and sigma of 26.0293, exact predict method and fit method, and random active set method. RBNN, RNN and GPR models were evaluation using the metrics of RMSE, R2, MAE and inference time.

$$y = 0.0054 x^4 + 0.0254 x^2 - 0.047 x + 0.4327 \quad (1)$$

III. RESULTS AND DISCUSSIONS

A. Vision-Based Microalgae Photobioreactor

Implementation of advanced technologies in biosystem setup for cultivating microalgae has fascinated both agriculturists, engineers, and scientists [1,3,6,9,10,18,21,22,24,25,29]. It involves the adjustment of light source, variations on nutrient injection rates, and innovations on the grow bed or bioreactor itself. The developed *Chlorella vulgaris* microalgae photobioreactor is equipped with artificial white light source and Peltier plates that adjust the light intensity and water temperature level in exploring what is the optimum combination of these environmental stressors will generate the significant biomass with consideration of cultivar life cycle (Fig. 7a).



Chlorella Vulgaris Surface-Mount Photobioreactor with Vision-Based Growth Signature Prediction Optimized by Electromagnetism-Like Mechanism

It is noticeable that the developed automated photobioreactor is effective for moving its physical placement in

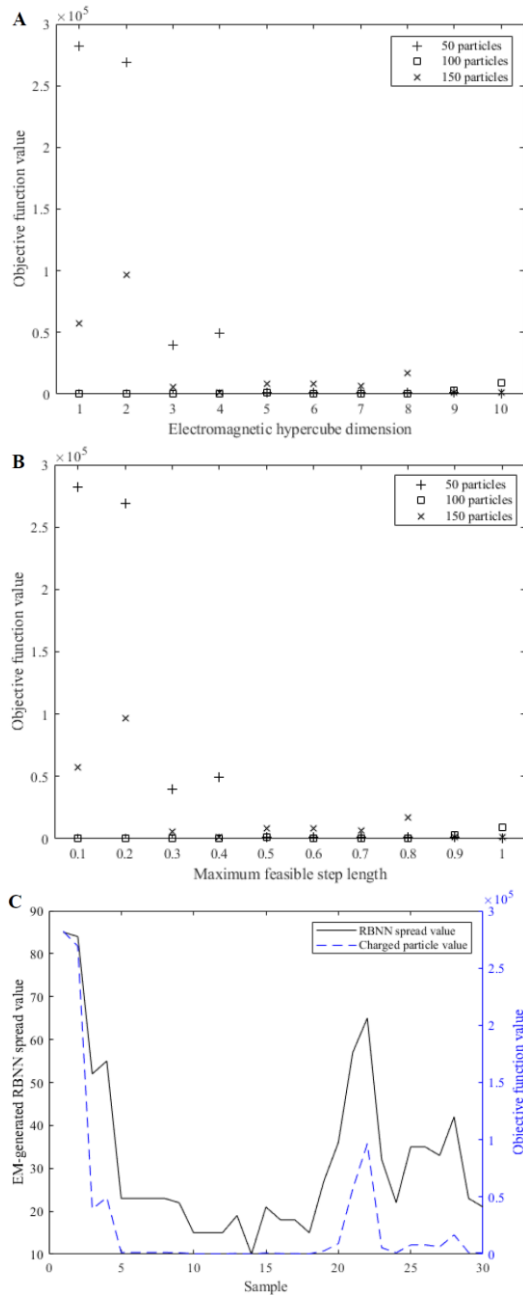

Fig 6. Particle charge response with varying electromagnetic hypercube dimension and maximum feasible step length, and its interaction with the spread factor of radial basis neural network

a large phytotron as it has wheels beneath it. Moreover, the structure is compact and scalable for larger production of biomass. It employs adaptive bioreactor environment condition management by just choosing what type of microalgae will be cultivated. It means that the system automatically configures the suitable range for biomass production. With enough pre-harvest factors based on the requirements of photosynthesis, which are light energy, carbon dioxide, and water, the microalgae bioreactor generates comparable biomass. The greener colonies of eukaryotic species are the growing *Chlorella vulgaris* as expected because the bioreactor is subjected to minimum amount of light energy and temperature as part of the

photosynthetic requirement (Fig. 7b). The overlaying of 10,000 superpixels over the raw captured image enables segmentation of biomass from non-algae pixels (Fig. 7c). Five color clusters were used to provide efficient segmentation which are white, red, green, blue, and black. Hence, the developed three photobioreactor acts independently one each other because of the embedded automations on separate systems which is comparable to locally dependent growth chambers using internally illuminated tubes [3] and eight series vertical columns [25]. The proposed surface-mount light photobioreactor was able to cultivate microalgae as the light is evenly spread over the water surface resulting to equal photosynthetic reaction among microalgae cultures throughout the cultivation period.

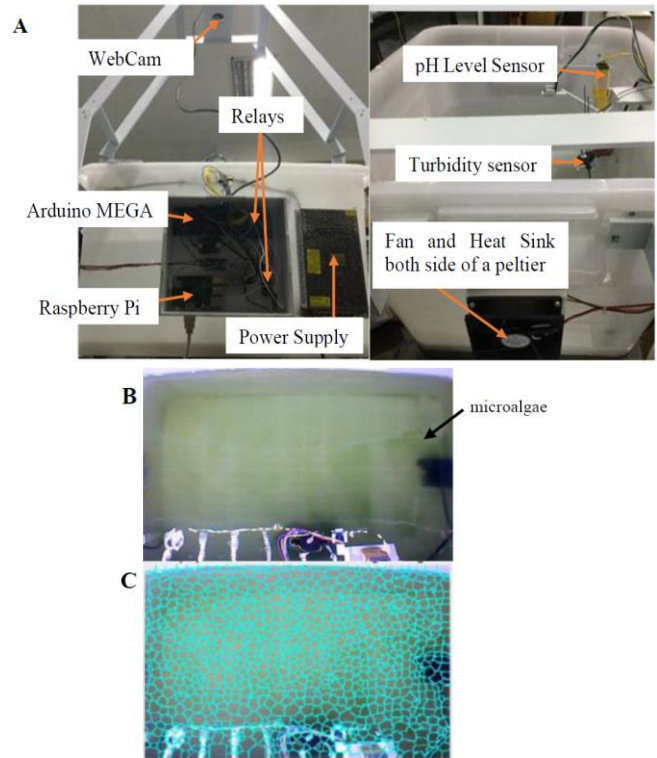

Fig 7. (a) Actual photobioreactor prototype, (b) microalgae biomass cultivation and (c) biomass segmentation using superpixels

B. Feature-based Growth Signature Prediction of *Chlorella Vulgaris*

Based on hybrid neighborhood component analysis and ReliefF-selected spectral and abiotic environmental stressors, (2) and (3) are the corresponding regression models. $A_{\text{biomass}(c)}$ denotes the biomass area that can be generated using the spectral signatures of microalgae with R^2 of 0.9788 where θ , ε , γ , ψ and μ are the spectral component values of hue, saturation, cyan, yellow, and magenta, respectively. On the other hand, $A_{\text{biomass}(e)}$ denotes the biomass area that can be generated using the selected abiotic environmental stressors of temperature (τ) and pH concentration (ρ) with R^2 of 0.93.

$$A_{\text{biomass}(c)} = 53.1 - 22.9 \theta + 9.17 \varepsilon + 0.39 \gamma - 0.696 \psi + 0.229 \mu \quad (2)$$



$$A_{\text{biomass}(e)} = 16.34 + 0.210 \tau + 0.378 \rho \quad (3)$$

Nine different combinations of controlled environmental stressors were separately configured on the customized photobioreactors. Matured microalgae biomass is visually recognizable with darker green color resembling the accumulation of photosynthetic pigment and thickening of algal strands (Fig. 7b). Captured microalgae surface images were quantitatively assessed by predicting its surface area based on environmental pre-harvest factors and spectral signatures using optimized general processing regression, recurrent neural network, and radial basis neural network. Machine learning modes were suffixed with numerical subscripts of 4 and 2 denoting the number of environmental stressors used as predictors in estimating biomass surface area such as GPR₄ for general processing regression using the unreduced features of water temperature, pH, turbidity and light intensity (Fig. 8). Whereas RNN₂ resembles recurrent neural network using the hybrid NCA and ReliefF-selected high impact features of water temperature and pH concentration. Equally, GPR₁₅ resembles GPR using the 15 original pre-selected spectral features of five color spaces, and RBNN₅ is for RBNN using yellow, magenta, hue, cyan,

and saturation components as predictors. For predicting microalgae biomass surface area with environmental stressors as predictors, EM-RBNN₂ bested out GPR and RNN variants with RMSE of 6.262, R² of 0.985 and MAE of 2.847 (Table 4). However, it is noticeable that RNN₂ and RNN₄ performed the shortest inference time of 4 seconds despite of its network looping in triple staged hidden layer. It is 87.8% faster than the most sensitive RBNN₂. For predicting microalgae biomass surface area with spectral signatures as predictors, EM-RBNN₅ performed the most accurate, sensitive, and responsive model with RMSE of 10.489, R² of 0.944 and MAE of 5.160 (Table 4). RNN variants still turned out to have the fastest inference time of 81.42% than RBNN₅. It is evident that predictions using models requiring higher number of input features resulted to longer inference time. Among the included machine learning models, RBNN variants exhibited the most consistent performance from training, validation and testing phases depicting perfect sampling and no overfitting or underfitting is involved. Overall, RBNN₂ using water temperature and pH that is improved by EM resolved to have optimum performance in evaluating microalgae biomass surface area.

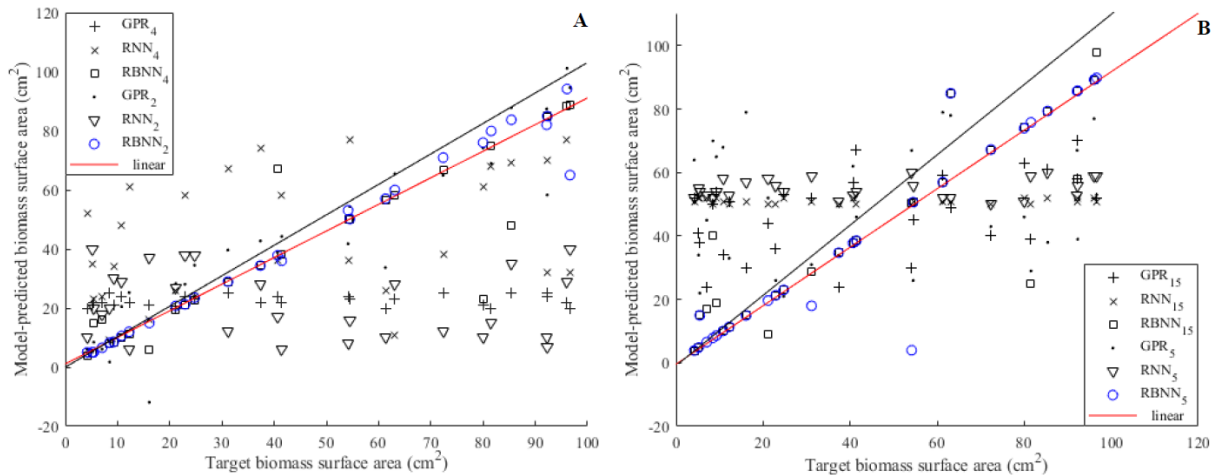

Fig 8. (a) Regression lines in predicting *Chlorella vulgaris* surface area using (a) abiotic environmental stressors and (b) spectral signature of biomass

Table- IV: Name of the Table that justify the values

Model	No. of Features	Training			Validation			Testing			Inference Time (s)
		RMS E	R ²	MAE	RMS E	R ²	MAE	RMS E	R ²	MAE	
Using Abiotic Environmental Stressors as Predictors											
GPR	4	12.916	0.03	11.36	39.021	0.04	30.04	35.482	0.12	25.40	24.251
GPR	2	6.284	0.20	4.494	6.549	0.97	4.690	10.695	0.93	6.690	12.744
RNN	4	11.616	0.07	9.131	33.732	0.02	26.41	29.011	0.35	22.28	4.000
RNN	2	12.389	0.10	10.67	29.309	0.23	21.54	39.070	0.16	29.54	4.000
RBNN	4	0.893	0.97	0.707	10.086	0.90	3.541	13.535	0.90	6.933	36.116
RBNN	2	0.893	0.98	0.707	10.086	0.93	3.541	6.262	0.98	2.847	32.784

Chlorella Vulgaris Surface-Mount Photobioreactor with Vision-Based Growth Signature Prediction Optimized by Electromagnetism-Like Mechanism

Using Biomass Spectral Signatures as Predictors											
GPR	15	10.835	0.008	9.112	42.930	0.195	34.013	28.578	0.299	23.397	48.148
GPR	5	12.699	0.177	11.160	32.445	0.209	24.381	33.220	0.103	25.659	36.740
RNN	15	14.284	0.151	12.176	32.476	0.103	24.666	30.385	0.068	25.284	5.000
RNN	5	23.125	0.059	22.153	29.554	0.126	21.143	30.973	0.218	25.821	4.000
RBNN	15	26.259	0.924	0.898	18.365	0.909	0.987	14.083	0.885	7.454	51.215
RBNN	5	0.875	0.955	0.742	20.040	0.887	0.988	10.489	0.944	5.160	24.220

Unlike a destructive testing of extracting biomass tissues from time to time in order to monitor its growth by weighting it [3, 25], this study is definite in predicting microalgae growth based on the intensity of color reflectance in various color spaces and abiotic environmental stresses as a nondestructive approach (Table 4).

C. Chlorella vulgaris cultivation and limnological interaction

The photobioreactor 1 (PBR1) with light intensity of 1,000 lux and water temperature of 22°C successfully cultivated a 26.422 cm² *Chlorella vulgaris* biomass surface area after a 30 days of cultivation period with 6.597 cm² growth from the first week baseline growth of 19.825 cm² (Fig. 9). Exposing *Chlorella vulgaris* and BG-11 growth medium to light intensity of 1,000 lux and increasing temperature up to 32°C substantially decreased the generated biomass surface by 51.707%. Photobioreactor 2 configured with condition 1 (PBR2-COND1) has total increase of 7.193 cm² of biomass surface after the cultivation period while PB2-COND2 is characterized with an increase of 6.883 cm². PBR2-COND1 and PBR2-COND2 conditions primarily differ with the generated biomass surface area during first week with 20.166 cm² for PBR2-COND1 and 17.936 cm² for PBR2-COND2. Photobioreactor 3 configured with condition 1 (PBR3-COND1) having water temperature of 22°C and 3,000 lux generated an increase of 4.281 cm² over a period of one month where PBR3-COND3 having water temperature of 32°C and 3,000 lux is short of 0.04 cm².

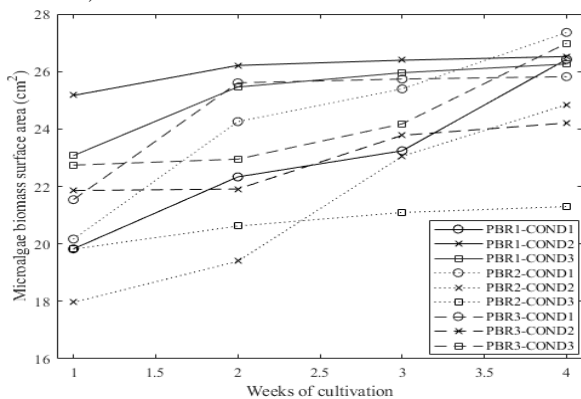

Fig 9. Growth curve of chlorella vulgaris biomass surface area in three environmentally controlled photobioreactors

In terms of limnological parameters interaction, there is an increase of 14.075% in pH and 61.58% for the turbidity as water temperature is increased from 22°C to 32°C with constant 1,000 lux (Fig. 10). However, pH concentration is

lightly weakened by 5.39% and turbidity is increased by 14.777% for the controlled environment emitting 2,000 lux. Like the PBR1, photobioreactor 3 that is equipped with 3,000 lux artificial lighting contained a noticeable increase of 31.579% for pH concentration and 2.473% in turbidity. With this, turbidity is highly reliable with light intensity and the growth of biomass on water surface as there is 59.107% deviation per 2,000 lux increase. Conversely, pH is highly affected by light intensity with 17.504% rise per 2,000 lux increase. There is also considerable growth in biomass surface area for certain combinations of light intensity and water temperature such as 1,500 to 2,750 lux and 25.5 to 32°C, and turbidity and water pH concentrations of 3.7 to 4 NTU and 7.25 to 8.8, respectively (Fig. 10). However, PBR2-COND2 with 27°C and 2,000 lux is considered as the exact optimum controlled environment condition in cultivating *Chlorella vulgaris* based on the generated growth in biomass surface area of 38.314%.

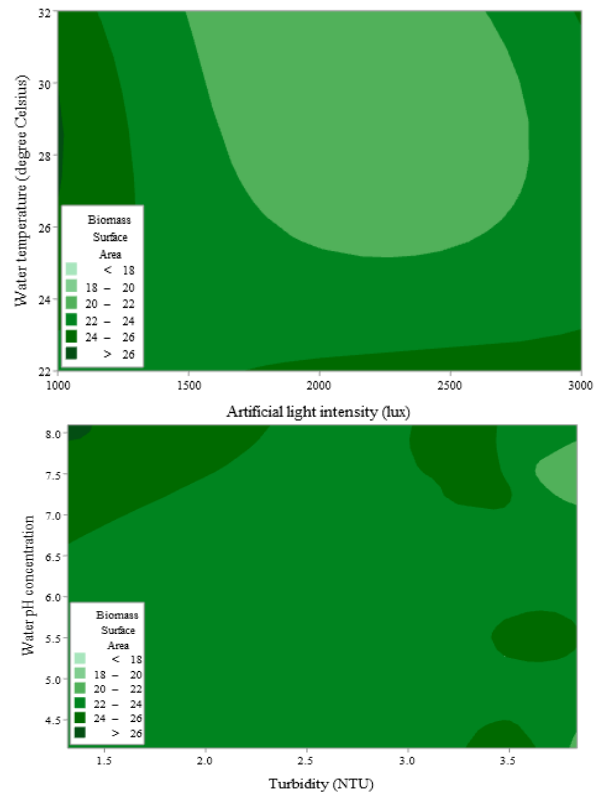

Fig 10. Impacts of limnological parameters inside the controlled photobioreactors to chlorella vulgaris biomass surface area

IV. CONCLUSIONS

This study demonstrated the development of a surface-mount light photobioreactor equipped with Peltier plates, computer vision and wireless sensor network for the cultivation of *Chlorella vulgaris*, and the implementation of computational intelligence for its growth prediction. Three photobioreactors were constructed that works independently with each other based on the configured automation in the adjustment of abiotic environmental stressors in terms of water temperature and light intensity that helps the photosynthetic process of microalgae tissue to grow inside this controlled environment chamber. Consumer-grade digital RGB camera visually monitors and captures images of the microalgae being cultivated and the images were used to extract biophysical signatures of microalgae. Array of pH, temperature, turbidity, and light sensors was placed inside the photobioreactors and connected to the IoT for seamless transmission of important environmental data. Artificial seawater was mixed using laboratory-grade chemicals to create pure nutrient medium for microalgae cultures. Cyan, yellow, magenta, hue, saturation, and biomass area are the highly selected spectro-morphological signatures for growth rate prediction of microalgae using hybrid neighborhood component analysis and ReliefF algorithms. Generalized processing regression, recurrent neural network and radial basis neural network optimized using electromagnetism-like mechanism were used in predicting the actual microalgae surface based on the pre-selected signatures. Accordingly, these are the following outcomes were obtained: EM-RBNN performed the best prediction accuracy and sensitivity with lower RMSE score, the best photobioreactor environment condition in cultivating *Chlorella vulgaris* exhibits 27°C water temperature and 2000 lux exposure, turbidity has direct relation with light intensity and accumulation of biomass tissue on water, and pH is highly affected by light concentration. Overall, there is significant benefit in cultivating microalgae in a closed environment biosystem as proper photosynthetic requirements will be met in all season. For future studies, it is recommended to employ techno-economic analysis to comprehensively assess the impact of materializing this biosystem in larger scale.

ACKNOWLEDGMENT

The authors would like to acknowledge the support of the Engineering Research and Development for Technology (ERDT) of the Department of Science and Technology (DOST) of the Philippines and the Intelligent Systems Laboratory of the De La Salle University, Philippines.

REFERENCES

1. Ubando AT, Felix CB, Gue IH V., et al. Priority Evaluation of Life Cycle Impact Factors for Algal Biofuel Production in the Philippines Using Analytic Hierarchy Process. *Appl Mech Mater*. 2016;842:355-364. doi:10.4028/www.scientific.net/amm.842.355
2. Ubando AT, Gue IH V., Mayol AP, et al. Life cycle validation study of algal biofuels in Philippines via CML impact assessment. *IEEE Reg 10 Humanitarian Technology Conference R10-HTC 2015 - co-located with 8th International Conference on Humanoid, Nanotechnology, Information Technology, Communication, Control, Environmental Management HNICEM* 2015. 2016:0-4. doi:10.1109/R10-HTC.2015.7391871

3. Almomani F, Al Ketife A, Judd S, et al. Impact of CO₂ concentration and ambient conditions on microalgal growth and nutrient removal from wastewater by a photobioreactor. *Sci Total Environ*. 2019;662:662-671. doi:10.1016/j.scitotenv.2019.01.144
4. Concepcion R, Loresco PM, Bedruz RA, Dadios E, Lauguico S, Sybingco E. Trophic state assessment using hybrid classification tree-artificial neural network. *International Journal of Advances in Intelligent Informatics*. 2020;6(1):46-59. doi: 10.26555/ijain.v6i1.408
5. Wada Patella, Rodrigo S. Jamisola Jr., Moathodi W. Letshwenyo AMN. A Survey on Management of Upstream Land Use and its Impact on Downstream Water Quality Parameters. *J Comput Innov Eng Appl*. 2017;2(1):1-11.
6. Shin YS, Choi H II, Choi JW, Lee JS, Sung YJ, Sim SJ. Multilateral approach on enhancing economic viability of lipid production from microalgae: A review. *Bioresour Technol*. 2018;258:335-344. doi:10.1016/j.biortech.2018.03.002
7. Concepcion RS, Bedruz RAR, Culaba AB, Dadios EP, Pascua ARAR. The Technology Adoption and Governance of Artificial Intelligence in the Philippines. 2019 IEEE 11th Int Conf Humanoid, Nanotechnology, Inf Technol Commun Control Environ Manag HNICEM 2019. 2019. doi:10.1109/HNICEM48295.2019.9072725
8. Benedetti M, Vecchi V, Barera S, Dall'Osto L. Biomass from microalgae: The potential of domestication towards sustainable biofactories. *Microb Cell Fact*. 2018;17(1):1-18. doi:10.1186/s12934-018-1019-3
9. Mayol AP, San Juan JLG, Sybingco E, et al. Environmental impact prediction of microalgae to biofuels chains using artificial intelligence: A life cycle perspective. *IOP Conf Ser Earth Environ Sci*. 2020;463(1). doi:10.1088/1755-1315/463/1/012011
10. San Juan JLG, Mayol AP, Sybingco E, et al. A scheduling and planning algorithm for microalgal cultivation and harvesting for biofuel production. *IOP Conf Ser Earth Environ Sci*. 2020;463(1). doi:10.1088/1755-1315/463/1/012010
11. Khan MI, Shin JH, Kim JD. The promising future of microalgae: Current status, challenges, and optimization of a sustainable and renewable industry for biofuels, feed, and other products. *Microb Cell Fact*. 2018;17(1):1-21. doi:10.1186/s12934-018-0879-x
12. Culaba AB, Juan JLG, Ching PML, Mayol AP, Sybingco E, Ubando A. Optimal Synthesis of Algal Biorefineries for Biofuel Production Based on Techno-Economic and Environmental Efficiency. 2019 IEEE 11th Int Conf Humanoid, Nanotechnology, Inf Technol Commun Control Environ Manag HNICEM 2019. 2019:0-4. doi:10.1109/HNICEM48295.2019.9072730
13. Chang H, Quan X, Zhong N, et al. High-efficiency nutrients reclamation from landfill leachate by microalgae *Chlorella vulgaris* in membrane photobioreactor for bio-lipid production. *Bioresour Technol*. 2018;266:374-381. doi:10.1016/j.biortech.2018.06.077
14. Anto S, Mukherjee SS, Muthappa R, et al. Algae as green energy reserve: Technological outlook on biofuel production. *Chemosphere*. 2020;242. doi:10.1016/j.chemosphere.2019.125079
15. Xie B, Gong W, Tian Y, et al. Biodiesel production with the simultaneous removal of nitrogen, phosphorus and COD in microalgal-bacterial communities for the treatment of anaerobic digestion effluent in photobioreactors. *Chem Eng J*. 2018;350(March):1092-1102. doi:10.1016/j.cej.2018.06.032
16. Mayol AP, Ubando AT, Mandia E, Mendoza DM, Sybingco E, Culaba A, Dadios E. Development of a microalgal automated cultivation system on *Tetrademus obliquus*. *Journal of Computational Innovations and Engineering Applications*. 2017;2(1):27-32.
17. Abou-Shanab RAI, Ji MK, Kim HC, Paeng KJ, Jeon BH. Microalgal species growing on piggery wastewater as a valuable candidate for nutrient removal and biodiesel production. *J Environ Manage*. 2013;115:257-264. doi:10.1016/j.jenvman.2012.11.022
18. Carneiro M, Cicchi B, Maia IB, et al. Effect of temperature on growth, photosynthesis and biochemical composition of *Nannochloropsis oceanica*, grown outdoors in tubular photobioreactors. *Algal Res*. 2020;49(April):101923. doi:10.1016/j.algal.2020.101923
19. Tan XB, Lam MK, Uemura Y, et al. Semi-continuous cultivation of *Chlorella vulgaris* using chicken compost as nutrients source: Growth optimization study and fatty acid composition analysis. *Energy Convers Manag*. 2018;164(March):363-373. doi:10.1016/j.enconman.2018.03.020

Chlorella Vulgaris Surface-Mount Photobioreactor with Vision-Based Growth Signature Prediction Optimized by Electromagnetism-Like Mechanism

20. Azizi S, Bayat B, Tayebati H, Hashemi A, Shariati FP. Nitrate and phosphate removal from treated wastewater by *Chlorella vulgaris* under various light regimes within membrane flat plate photobioreactor. *Environ Prog Sustain Energy*. 2020. doi:10.1002/ep.13519
21. Nwoba EG, Parlevliet DA, Laird DW, Alameh K, Moheimani NR. Light management technologies for increasing algal photobioreactor efficiency. *Algal Res*. 2019;39(September 2018):101433. doi:10.1016/j.algal.2019.101433
22. Mustapa NS, Abu Mansor MS, Serri NA. Design and development of centred-light photobioreactor for microalgae cultivation system. *IOP Conf Ser Mater Sci Eng*. 2020;716(1). doi:10.1088/1757-899X/716/1/012009
23. Folorunso P, Petrini S, Andreottola G. Evolution of real municipal wastewater treatment in photobioreactors and microalgae-bacteria consortia using real-time parameters. *Chem Eng J*. 2018;345:507-516. doi:10.1016/j.cej.2018.03.178
24. Pozzobon V, Levasseur W, Guerin C, Gaveau-Vaillant N, Pointcheval M, Perré P. *Desmodesmus* sp. pigment and FAME profiles under different illuminations and nitrogen status. *Bioresour Technol Rep*. 2020;10(Febuary). doi:10.1016/j.biteb.2020.100409
25. Rebolledo-Oyarce J, Mejía-López J, García G, Rodríguez-Córdova L, Sáez-Navarrete C. Novel photobioreactor design for the culture of *Dunaliella tertiolecta* – Impact of color in the growth of microalgae. *Bioresour Technol*. 2019;289(June):121645. doi:10.1016/j.biortech.2019.121645
26. Ruiz-Santaquiteria J, Bueno G, Deniz O, Vallez N, Cristobal G. Semantic versus instance segmentation in microscopic algae detection. *Eng Appl Artif Intell*. 2020;87(April 2019):103271. doi:10.1016/j.engappai.2019.103271
27. Lauguico SC, Concepcion RIS, Alejandrino JD, Tobias RR, Dadios EP. Lettuce life stage classification from texture attributes using machine learning estimators and feature selection processes. *Int J Adv Intell Informatics*. 2020;6(2):173. doi:10.26555/ijain.v6i2.466
28. Concepcion R.S., Ilagan L.C., Valenzuela I.C. (2020) Optimization of Nonlinear Temperature Gradient on Eigenfrequency Using Genetic Algorithm for Reinforced Concrete Bridge Structural Health. In: Beltran Jr. A., Lontoc Z., Conde B., Serfa Juan R., Dizon J. (eds) *World Congress on Engineering and Technology; Innovation and its Sustainability 2018*. WCETIS 2018. EAI/Springer Innovations in Communication and Computing. Springer, Cham. 2018, 141 – 152 https://doi.org/10.1007/978-3-030-20904-9_11
29. Zhen-hong Huang, Li-jin Lian, Liang Hu, and Xue-juan Hu "Monitoring of microalgae growth in different environments based on spectral analysis", *Proc. SPIE 11427, Second Target Recognition and Artificial Intelligence Summit Forum, 114273V* (31 January 2020); <https://doi.org/10.1117/12.2553071>
30. Rashvand M, Zenouzi A, Abbaszadeh R. Potential of image processing, dielectric spectroscopy and intelligence methods in order to authentication of microalgae biodiesel. *Meas J Int Meas Confed*. 2019;148:106962. doi:10.1016/j.measurement.2019.106962
31. Concepcion RS, Cruz FRG, Uy FAA, Baltazar JME, Carpio JN, Tolentino KG. Triaxial MEMS digital accelerometer and temperature sensor calibration techniques for structural health monitoring of reinforced concrete bridge laboratory test platform. 2017 IEEE 9th International Conference on Humanoid, Nanotechnology, Information Technology, Communication and Control, Environment and Management (HNICEM). 2017. doi:10.1109/hnicem.2017.8269422
32. Concepcion, R. S., Lauguico, S. C., Tobias, R. R., Dadios, E. P., Bandala, A. A., & Sybingco, E. (2020). Estimation of Photosynthetic Growth Signature at the Canopy Scale Using New Genetic Algorithm-Modified Visible Band Triangular Greenness Index. 2020 International Conference on Advanced Robotics and Intelligent Systems (ARIS). doi:10.1109/aris50834.2020.9205787

AUTHORS PROFILE



Ronnie Concepcion II received his Master of Science Degree in Mapua University, Manila, Philippines and currently a PhD in Electronics and Communications Engineering at the De La Salle University, Manila. He has published more than 30 scientific journal articles, book chapters and conference proceedings in the national and

international levels and received best paper award in Cambodia for his engineering work of artificial intelligence. His research interest includes biosystems engineering, intelligent systems, artificial intelligence, computer vision, plant imaging, and plant science. Currently, a recipient of the Engineering Research and Development for Technology (ERDT)

Retrieval Number: 100.1/ijrte.D5007119420

DOI:10.35940/ijrte.D5007.119420

Journal Website: www.ijrte.org

scholarship of the Department of Science and Technology (DOST), Philippines, and the lead researcher of the Smart Farm research project of the Intelligent Systems Laboratory of DLSU.



Michael Jon Alain Saavedra received his Bachelor of Science in Electronics Engineering from the University of Perpetual Help Systems DALTA, Las Piñas City, Philippines. His research interest includes biosystems engineering, image processing, and wireless communications. His other research and development outputs were satellite communication system plan and 2.4GHz microwave system design for air navigation traffic data. Currently, he is doing a professional research about Internet-of-things under UPHSD Las Piñas City campus.



Jonnel Alejandrino at the present time is on track of his Master of Science in Electronics and Communications Engineering at the De La Salle University, Manila, the Philippines in the field of Artificial Intelligence for cognitive wireless communications and network systems. He finished his Bachelor of Science in Electronics and Communications Engineering at the Laguna State Polytechnic University last 2018. His learning experience in research development and technology was a rich one. He has a disparate contribution to Climate Change Mitigation, Adaptation & Disaster Risk Reduction Strategy of Harmonized National R&D Agenda. His former period researches bagged several awards in national investigatory project competitions in the principality of computational chemistry, particularly in water impurities. He was adequate to publish several technical and scientific papers aligned with his research specialties which are wireless communications, network system, sustainable agriculture, and structural health monitoring, biochemical engineering, computational intelligence, and intelligent systems. He is also a constituent of various research programs like Information and Communication System for Disaster Resilience and Hydroponics and Aquaponics system of smart farming. He is licensed electronics engineer and technician, an amateur radio operator class B. He is also member of the Institute of Electrical and Electronics Engineers Republic of Philippines Section.



Maria Gemel Falconit is a faculty member at the Electronics and Communications Engineering Department, Cebu Technological University. She is currently pursuing a Doctor of Philosophy in Electronics and Communications Engineering at De La Salle University. Throughout her academic journey, she has been a recipient of the scholarship programs from the Department of Science and Technology—RA 7687 in her undergraduate studies at Eastern Visayas State University and Engineering Research and Development for Technology (ERDT) at the University of San Carlos and De La Salle University. Her research interest is currently on the application of intelligent systems, IoT, computer vision, control systems, and signal processing.

