

Surveillance FPV Drone with Obstacle Avoidance System



Sunay Dharwadkar, Sarvesh Harmalkar, Chinmay Nagzarkar, Vivkanand Tendulkar

Abstract: *The unmanned air vehicle (UAV) is mostly used in inspection and surveillance operations recent. The UAV is also termed as vertical take-off landing (VTOL), since it is capable of vertical take-off and landing without need of a runway. The big tunnels, infrastructure and large bridges are inserted using UAV by photographic inspection. UAVs are also used for surveillance purposes by the military and by the security guards. Since this is a new technology of the last decade, deep research has to be done. UAVS have the cross structure arrangement to which the rotor blades are attached at the end points of cross beams. These rotors are driven by the DC brush motors and motors are powered by the lithium ion rechargeable battery. The working principle of quad-rotors is the same as the chopper by controlling the rpm of each rotor blade, due to which the gyroscopic torque will act and the vehicle will move in the desired direction. To hold the quad-rotor at a stationary position at some height constant rpm of all rotors has to be maintained. This signal is given by the controller from some distance, which is received by the, and then it processes the signal and drives the motor via the flight controller and drives the rotors. A quad-rotor is equipped with a high quality camera for photography and video shooting during surveillance. Since a quad rotor is manoeuvring in air, the wind may exert a drag force and take it along with it and the quad rotor may hit any obstacle or inspection objects. To avoid this, it is equipped with the ultrasonic sensors which is capable of sensing the obstacle and realize collision avoidance between wall or any object.*

Keywords: *About four key words or phrases in alphabetical order, separated by commas.*

I. INTRODUCTION

The first air craft was designed by Wright brothers in 1903, but the research had started by many scientists and researchers many years ago. The first unmanned air vehicle (UAV) was in 1920-1930. It is capable of take-off landing and given (VTOL). Sometimes it also called a remotely piloted air system (RPAS). RPAS term is commonly used by the civil and commercial aviation sector and UAV is commonly used by industry. The quad-rotor has a cross beam structure with

the rotors are mounted at the end of each beam. The quad-rotor is driven by DC motors and motors are powered by the lithium ion chargeable battery. When a signal is given to the quad rotor it starts the motor, along with it the rotor rotates, and when we provide the signal for take-off just increases the rpm of the rotor and it can stay at particular height by maintaining constant rpm. The application of quad-rotors are man, that it is used as toy by kids and also used by military people for defence purposes. Our focus is on the use of quad-rotor for inspection and for surveillance. Due to its low cost and high flexibility it is commonly used by industry people for surveillance and by the civil engineers for the inspection infrastructure, high bridges road and tunnels. The quad rotors are usually equipped with high quality camera and also with the obstacle avoidance system. The ultrasonic sensor us mostly for obstacle avoidance since it is suitable for close range direction up to 10 meters and provides multiple range measurement per second. The advantages of this sensor is it is inexpensive, require low power and could work in environment where other sensors could no work, like LASER sensors which could not work in smoky environment.

II. PROBLEM STATEMENT

Previously the inspection of infrastructure high bridges, roads and tunnels were done by engineers, quality inspector, etc. Earlier, the large infrastructure inspection are carried out by close visual inspection and hammering tests. But it is difficult for tall Bridges with higher piers and tunnels with high ceiling due to this, the structure is not being frequently checked. it is difficult to inspect it. And also the surveillance is carried out by CCTV camera, soldiers in military security guard in industry during nighttime and by incognito Serving County. But this is a very expensive, time-consuming and very risky job since one may lose his life. So we consider these issues as our problem statement and with the aid to this project we are trying to solve these problems.

III. PROPOSED DESIGN

1. Frame: The Frame is lightweight and durable which is made by strong and advance engineering material which has excellent strength. The arm is equipped with dampers for safe landing, the arm also has multiple holes equipped with vibration free bracket for FPV Camera mounting.

Revised Manuscript Received on August 05, 2020.

* Correspondence Author

Sunay Dharwadkar*, Goa College of Engineering Ponda Goa, India.

E-mail: dhawadkarsunay9@gmail.com

Sarvesh Harmalkar, AITD Engineering College, Goa, India. E-mail:

sarveshharmalkar92@gmail.com

Vivekanand Tendulkar, Goa College of Engineering Farmagudi, Goa,

India. E-mail: vivekanandtendulkar@gmail.com

Chinmay Nagzarkar, PCCE College of Engineering Goa, India.

E-mail: jaishnagzarkar@gmail.com

© The Authors. Published by Blue Eyes Intelligence Engineering and Sciences Publication (BEIESP). This is an [open access](https://creativecommons.org/licenses/by-nc-nd/4.0/) article under the CC BY-NC-ND license (<http://creativecommons.org/licenses/by-nc-nd/4.0/>)

Surveillance FPV Drone with Obstacle Avoidance System



Figure: Frame

2. Flight Controller and ESC Stack:

The flight controller is Fly color S tower 40 A BIHeli_S ESC with F4 flight controller and OSD. It has 4 ESC on 1 board stack up with F4 flight controller, it has a built in Micro SD Card to which support max.32G TF-card. It supports PPM, PWM, SBUS.



Figure: Flight Controller

3. Camera:

The Camera is 1500TVL which can be used as both PAL and NTSC. The toggle switch is provided on the camera by which you can switch modes. The camera has 2.1 mm lens, min illumination of about 0.001lux/1.2f, powered by 5-30 v DC.

4. Motors:

The GoolRC DX2205 2300KV CW/CCW motor is designed to provide both quality and performance. IT is built from high aluminum alloy which is produced from CNC milling machine. Voltage of 11.1V, load current 19.2 A, Continuous power : 213W/11.1V. Diameter of shaft is 5mm bod length 17.5mm.

5. Video Transmitter :

The video transmitter is TS834 5.8 G 600MW with 48 number of channels having 200mA current for 600mW wireless power which assures 5 Km Distance in an open area

6. Battery:

The battery is 3 cells, 2300mah capacity.

IV. DRONE CALCULATIONS

DRONE CALCULATIONS

Mathematical calculations and analysis.

Power Thrust Calculations

All up weight $W = 1170.5g$

Number of motors/ propellers =4

Thrust force required 2341g

Thrust force required per motor 585.25g

Average efficiency of motors $\eta = 0.85$

Estimated set up speed RPM= 2300

motor voltage in volts $V = 11.1V$

Number of batteries in parallel = 1

Battery cell capacity in $C = 2300$

Propeller

Propeller Diameter in $D = 5$

Propeller Pitch in inches Pitch= 535

Propeller sweep area in square inches is given by .3.1

$A = 0.25 \cdot \pi \cdot 1963.49 \text{ sq. inch}(3.1)$

Propeller sweep area in square feet, given by . 3.2 is,

$A_{ft} = A \cdot [0.006944444 \text{ (ft}^2/\text{inch}^2)] = 13.635 \text{ sq. feet}(3.2)$

Full Throttle

Common thrust to weight ratio to generate the needed lift is 2. total lift generated, given by . 3.3 is

$Lift_{Total} = 2 \cdot 2 \times 1170.5 = 2341g(3.3)$

That is, $Lift_{Total} = 2341g \times 0.0022 = 5.1502$

Total lift of the UAV is, $Lift_{Total} = 5.1502$

Lift per each motor, given by . 3.4 is,

$Lift = Lift_{Total} / 4 = 5.1502 / 4 = 1.28755 \text{ lbf}(3.3)$

Lift per motor is also given by . 3.5 below,

$= TL \cdot (P_{in}) = 1.28755 (3.5)$

Thrust loading equation is given by . 3.6 as follows,

$TL = 8.6859 PL^{-0.3107} \cdot 1 (/ \text{hp})(3.6)$

Power loading equation is given by . 3.7 as follows,

$PL = (P_{in} \cdot \eta) / A_{ft}(3.7)$

Substituting for PL from . 3.7 in . 3.6, we get . 3.8 as follows,

$TL = 8.6859 ((P_{in} \cdot \eta) / A_{ft})^{-0.3107} \cdot 1 (/ \text{hp})(3.8)$

Solving . 3.5 and . 3.8 Simultaneously, we get the values for P_{in} and TL as follows, given in . 3.9 and . 3.10 below.

$= 0.16646 (3.9)$

$TL = 15.5487 / \text{hp}(3.10)$

Substituting values from . 3.9 in . 3.7 we get the value for PL given in . 3.11 below.

$PL = 0.1535 \text{ hp} / \text{sq. feet}(3.11)$

Power input to motors in Watts is given by . 3.12 below

$P_{inWatt} = P_{in} [745.7 \text{ W/hp}] = 124.129 \text{ W}(3.12)$

Motor rating in KV is given by . 3.13 below

$\text{rpm}/V = 2300/11.1 = 207.207(3.13)$

Nominal KV of motor () which accounts for efficiency is given by . 3.14 below.

$= / \eta = 243.77 \text{ kv}(3.14)$

Current of motor is given by . 3.15 below.

$= P_{inWatt} / V = 19.2 \text{ A}(3.15)$

Total UAV current is given by . 3.16 below.

$= x = 76.8 \text{ A}(3.16)$

Required ESC current for motor is given by . 3.17 below.

$= x \cdot 1.2 = 23.04 \text{ A}(3.17)$

we required 4 motors of around 243.77Kv rating each

Now referring to motor charts for the available options we selected, 4 of, 4108, 380 KV motor each of this has a weight of 93g, can produce maximum thrust of 1620 g can handle a maximum current of about 15 A, and have a speed of 2300 rpm at 11.1V and are compatible for 5 inch propellers.

in next set of analysis we found the design parameters considering maximum throttle and hover conditions, Full Throttle

Since each of the BLDC motors produces a max thrust of 1024g,

Thus, Total lift of the UAV is given by Eq. 3.18 below,



Lift_{Total} = 1024x4 = 4096g = 9.0112 lbf. (3.18)
Lift per each motor is given by Eq. 3.19 below.
Lift = Lift_{Total} / N_{Motor} = 9.0112/4 = 2.2528 lbf (3.19)
Ideally, Thrust to weight ratio = Lift_{Total} / W = 4096/1170.5 = 3.499
Considering 85% efficiency thrust generated would be 0.85x 4096 = 3481.6
And thus thrust to weight ratio = 3481.6/1170.5 = 2.974.
Lift per motor is given by Eq. 3.20 below.
Lift = TL · (P_{in} · η) = 3.564 lbf (3.20)
Thrust loading equation is given by Eq. 3.21 below.
TL = 8.6859 PL^{-0.3107} · 1 (lbf / hp) (3.21)
Power loading equation is given by Eq. 3.22 below.
PL = (P_{in} · η) / A_{ft} (3.22)
Substituting for PL from Eq. 3.22 in Eq. 3.21 we get Eq. 3.23 given below.
TL = 8.6859 ((P_{in} · η) / A_{ft})^{-0.3107} · 1 (lbf / hp) (3.23)
Solving Eq. 3.20 and Eq. 3.23 simultaneously, we get the values for P_{in} and TL as follows, given in Eq. 3.24 and Eq. 3.25 below.
P_{in} = 0.33517 hp (3.24)
TL = 12.5097 lbf / hp (3.25)
Substituting values from Eq. 3.24 in Eq. 3.22 we get the value for PL given in Eq. 3.26 below.
Thus PL = 0.30908 hp / sq.feet (3.26)
Power input to motors in Watts is given by Eq. 3.27 below.
P_{inWatt} = P_{in} · |745.7 W/hp| = 249.93 W (3.27)
Current of motor is given by Eq. 3.28 below.
I_{motor} = P_{inWatt} / V = 11.25A (3.28)
Total UAV current is given by Eq. 3.29 below.
I_{tot} = I_{motor} × N_{Motor} = 45A (3.29)
Required ESC current for motor is given by Eq. 3.30 below.
ESC_{req} = I_{motor} × 1.2 = 13.5A (3.30)
Hover
Total lift of the UAV, is given by Eq. 3.31 below.
Lift_{HTotal} = 1 · W = 1170.5g = 2.5751 lbf. (3.31)
Lift per each motor is given by Eq. 3.32 below.
Lift_H = Lift_{HTotal} / N_{Motor} = 2.5751/4 = 0.6437 lbf (3.32)
Lift per motor is given by Eq. 3.33 below.
Lift_H = TL_H · (P_{Hin} · η) = 0.643 lbf (3.33)
Thrust loading equation is given by Eq. 3.34 below.
TL_H = 8.6859 PL_H^{-0.3107} · 1 (lbf / hp) (3.34)
Power loading equation is given by Eq. 3.35 below.
PL_H = (P_{Hin} · η) / A_{ft} (3.35)
Substituting for PL from Eq. 3.35 in Eq. 3.34 we get Eq. 3.36
TL_H = 8.6859 ((P_{Hin} · η) / A_{ft})^{-0.3107} · 1 (lbf / hp) (3.36)
Solving Eq. 3.33 and Eq. 3.36 simultaneously, we get the values for P_{Hin} and TL as follows, given in Eq. 3.37 and Eq. 3.38 below.
P_{Hin} = 0.06089 hp (3.37)
TL_H = 21.25 lbf / hp (3.38)
Substituting values from Eq. 3.37 in Eq. 3.35 we get the value for PL given in Eq. 3.39 below.
Thus PL_H = 0.056 hp / sq.feet (3.39)
Power input to motors in Watts is given by Eq. 3.40 below.
P_{HinWatt} = P_{Hin} |745.7 W/hp| = 45.405 W (3.40)
Current of motor is given by Eq. 3.41 below.
I_{Hmotor} = P_{HinWatt} / V = 2.04527 A (3.41)
Total UAV current is given by Eq. 3.42 below.
I_{Htot} = I_{Hmotor} × N_{Motor} = 8.181 A (3.42)
Endurance

Hover endurance time based on the battery capacity and motor current and is given by Eq. 3.43 below.
T_{hover} = (60 · (C/1000) · N_{Batt}) / I_{Htot} = 41.81 minutes. (3.43)
Full throttle endurance time based on the battery capacity and motor current and is given by Eq. 3.44 below.
T_{fullthrottle} = (60 · (C/1000) · N_{Batt}) / I_{tot} = 10.45 minutes (3.44)
Average endurance time is given by Eq. 3.45 below.
T_{average} = (T_{hover} + T_{fullthrottle}) / 2 = 26.13 minutes. (3.45)
Thus through it is observed through mathematical calculations that our drone design yields an average flight time of around 26.13 minutes.
Additional payload
Additional payload = 3481.6 - 1170.5 = 3720g = 2.3kg
Thus, as seen through calculations this drone design is able to support an additional payload of 2.3 kg.

V. COLLISION AVOIDANCE SYSTEM

Collision avoidance system as the name suggest, protects the drone from collision from any obstacle such as walls. The idea behind it is simple, whenever any obstacle is detected from left side the drone drift towards right and same in all directions. By keeping everything simple we can manipulate the receiver signal which are going to flight controller chip. To detect the object we used Ultrasonic sensors. The Receiver receives signal from transmitter which is being held by the pilot. It handover the signal values to the collision avoidance micro controller, sensor gives value to micro controller, then the micro controller changes the value of receiver according to the sensors values and send it ti flight controller. Flight controller gets values from gyroscope sensor and send signal to electronic speed controller which intern runs motors.

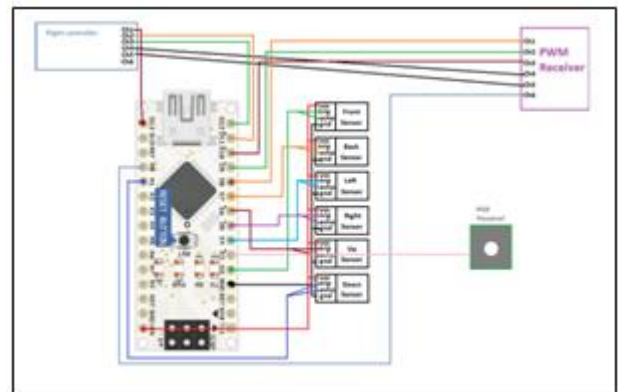

Figure: Collision avoidance system

VI. CONCLUSION AND FUTURE WORK

This article demonstrates design and fabrication of FPV drone. The avoidance is efficient and effect. The drone is capable of having good amount of surveillance. For future work we can incorporate more efficient sensor to have avoidance so that it can be more efficient. The following is the simulation results obtained for you.

Surveillance FPV Drone with Obstacle Avoidance System



Figure : FPV Drone

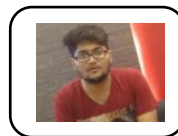

Vivekanand Tendulkar, BE Mechanical Engineering Goa College of engineering, Interested in robotics, IOT and innovative projects.



Chinmay Nagzarkar Be Mechanical Engineering Padre Conceicao College of Engineering Verna, Goa Interested in mechanical and Designing .



Figure : Structure inspection

ACKNOWLEDGMENT

We acknowledge our parents and the faculties who helped us built this drone.

REFERENCES

1. Prathamesh Salaskar , Saeed Paranjpe , Jagdish Reddy , Arish Shah, "Quadcopter – Obstacle Detection and Collision Avoidance," in International Journal of Engineering Trends and Technology (IJETT) – Volume 17 Number 2 – Nov 2014
2. Joseph Azetal, , Christian Bolu1 , Daniel Hinvi1 and Abiodun A Abioye1, "Obstacle detection using ultrasonic sensor for a mobile robot," in IOP Conf. Series: Materials Science and Engineering 707 (2019) 012012 IOP Publishing doi:10.1088/1757-899X/707/1/0120124.
3. Muhammad Fazlur Rahman, Rianto Adhy Sasongko, "Obstacle Avoidance for Quadcopter using Ultrasonic Sensor," in IOP Conf. Series: Journal of Physics: Conf. Series 1005 (2018) 012037 doi :10.1088/1742-6596/1005/1/012037
4. Marco Claudio De Simone * ID , Zandra Betzabe Rivera and Domenico Guida "Obstacle Avoidance System for Unmanned Ground Vehicles by Using Ultrasonic Sensors in machines.
5. Kenjiro Niwa, Keigo Watanabe, and Isaku Nagai "A Detection Method Using Ultrasonic Sensors for Avoiding a Wall Collision of Quadrotors," in International conference of mechatronics and Automation August 6-9, Takamatsu, Japan.

AUTHORS PROFILE



Mr Sunay Dharwadkar BE Mechanical engineering , from Goa college of engineering farmagudi ponda Interested in research oriented projects .

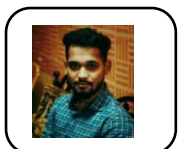

Sarvesh Harmalkar, BE Mechanical Engineering Agnel Institute Of Technology And Design Assgao Goa living in Bordem Bicholim Goa Interested in Mechanical and Aerospace Engineering