

# Influence of Tool Path Strategies and Pocket Geometry on Surface Roughness in Pocket Milling

MZA Yazid, Munzir Razak



**Abstract:** This paper discusses the effect of tool path strategies and pocket geometry to surface roughness due to pocket milling process. The machining processes have been performed on mould steel DF2 using carbide insert end mill as the cutting tool. The cutting parameters for this experiment were kept constant while the variables were cutting tool, path strategies and pocket geometries at three levels each. The effectiveness of different tool path strategy and different pocket geometry is evaluated in terms of measured surface roughness ( $R_a$ ) of the workpiece. The grade of a pocket is directly proportional with its surface roughness. The lowest surface roughness measurement was produced by pocket geometry B with parallel spiral cutting tool path strategy.

**Keywords :** Tool path strategy, pocket geometry, surface roughness, pocket milling.

## I. INTRODUCTION

The cutting tool path is the direction that leads cutting tool through the machined region. It is utilized to abolish all the substance inside some random closed partition space on a uniform surface of a workpiece to a fixed depth. Such a shape is regularly called a generalized pocket, or simply a “pocket”, and the process is called pocketing [1]. A pocket tool path’s purpose is to remove material from a cavity in the stock. Raised material defined by an enclosed contour inside a pocket, a boss, may be left standing in the cavity, if desired. This material left standing is commonly referred to as islands [2]. Mainly, there are two types of tool paths: spiral and zigzag [1]. The two types of tool paths are further categorized as normal and smooth spiral and normal and smooth zigzag. Milling of pocket features in machining parts may be fulfilled by applying different cutting path strategies [3]. In practices there are three of tool path in milling, which are back and forth or zigzag, spiral and one direction tool path strategies [4]. These tool direction strategies are often used in Computer Aided Manufacturing (CAM) software [3]. One direction is a tool direction strategy where the tool moves in side by side

line across the surface of workpiece to be machined. At the finish of line, the tool moves up and returns back to its original position, it then scans the area with a fixed step over values. For back and forth milling, the tool draws a zigzag cutter path by moving back and forth across the workpiece in the plane X – Y. Spiral milling is a tool direction strategy where the tool may start at the midpoint of the pocket and then proceeds spirally outside [3]. Quality of a pocket is evaluated directly with its surface quality. Good surface quality is essential because product functionality such as wearing, contact, coating and heat transmission could be affected by poor surface roughness [5]. Thus, it is important to put extra attention in choosing the right strategy to generate tool path and pocket geometry because these may influence other main parameters such as path cutting forces, length of the tool, surface roughness, machining time. The roughness is highly depending on material types, tooling types, cutting parameters and machining types. The scales of surface roughness essentials are based on suitable cutting parameter selections. Therefore, it is significant to conduct such experiment to determine the optimum parameters [6]. The factors subsidizing to the surface roughness are mechanical stiffness tool geometries, and cutting conditions while utilizing the conventional end milling machine tools. Meanwhile, feed rate and spindle speed known as a parameters of cutting condition, is the most significant on surface roughness. In the production of mould and dies, to reduce machining time, high speed milling is commonly employed. High speed machining (HSM) means utilizing cutting speeds that are remarkably higher than those used in standard machining operations. Normal HSM spindle paces range between 3500 and 8000 rpm, despite some spindles today are designed to overcome speed at 100,000 rpm, depending on the size of the spindle. In the past, the impact of pocket geometry and tool path strategy in term of machining time and cutting forces on surface roughness has been researched especially on a flat surface. However, there is limited literature on the influence of tool path strategies and pocket geometry in pocket milling for mould steel material that involves many pocketing processes during the production of mould and die using HSM. The focus of this research project to investigate the impact of tool path strategies and pocket geometry on surface roughness in pocket milling of mould steel DF2 material, which is the most commonly utilised steel for plastic mould [7].

Manuscript received on May 25, 2020.

Revised Manuscript received on June 29, 2020.

Manuscript published on July 30, 2020.

\* Correspondence Author

**M.Z.A. Yazid**, Associate Professor, Department of Manufacturing Section, Universiti Kuala Lumpur-Malaysia

**Munzir Razak**, Master of Engineering Technology (Manufacturing), Universiti Kuala Lumpur-Malaysia Italy Design Institute, Kuala Lumpur, Malaysia.

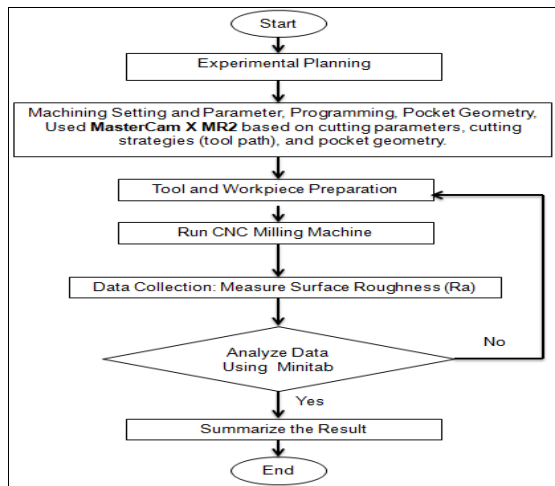
© The Authors. Published by Blue Eyes Intelligence Engineering and Sciences Publication (BEIESP). This is an [open access](https://creativecommons.org/licenses/by-nc-nd/4.0/) article under the CC BY-NC-ND license (<http://creativecommons.org/licenses/by-nc-nd/4.0/>)

## II. METHODOLOGY

This investigation focused on influences of a different tool path strategy and different pocket geometry on surface roughness in pocket milling. The pocketing tests have been performed on mould steel DF-3 and using carbide insert end mill as cutting tool in this project.

The cutting parameters were kept constant while the variable in this project are the three level of tool direction strategies; (one direction path, back and forth path, and spiral cutter path) and three level of pocket geometry. The results from the machining are surface roughness is investigated. The effectiveness of different tool path strategy and differ pocket geometry is evaluated in terms of surface roughness generated.

Figure 1 shows the experiment workflow utilized to perform the project being executed from the beginning until the finish of the project as described. The research scopes are to identify the impact of tool path strategy and also pocket geometry on surface roughness in pocket milling major research work being delegated in this research workflow chart, there are several stages of workflow to be followed.



**Fig. 1. Experiment Workflow**

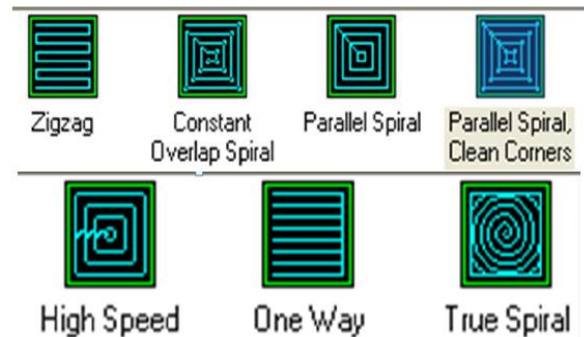
### A. Workpiece Material and Tooling

Author (s) The workpiece is mould steel DF2 blocks of 100 mm × 100 mm × 16 mm, and the cutting tool is 2-flute Kennametal DIN 6528 solid carbide end-flat mills of 10 mm of diameter and a helix angle 30°. The machining trials are ran under dry conditions at a feed rate of 300 mm/min, a spindle speed of 10,000 rpm and depth of cut of 0.30 mm.

The workpieces, made up of Mould Steel DF-3 DIN 1.2510, are best dimensional stability during hardening, fine combination of high surface hardness and toughness, and a best machinability later when hardening and tempering. Because of that, mould steel is one of the most frequently utilized material for plastic mould [8].

Carbide has greater hardness, has higher rigidity, and can withstand higher cutting temperatures, compared with HSS tool material. These substantial properties let carbide tools to machining at higher speeds and feeds, increasing production rates while providing extended tool life [2]. Always select the shortest end mill be able for the project to acquire highest tool rigidity [2].

In order to acquire the best cutting path strategy, MasterCam X MR2 software have been used to utilize the cutting path for machining workpiece into CNC end milling machine. Machining Setting and Programming (MASTERCAM X MR2) based on cutting strategies before running the CNC end milling machine, there are various setting need to be competed in order to get the correct process method for machining the product of workpiece. Mastercam X MR2 software was used to select the milling cutting path strategies of each cutting process [9]. All the parameters are in a constant value of setting. Other than that, the parameters also must be allocated to accomplish the condition of machining such as depth, cutting speed and feed rate of cut which is important in order to observe the correct parameters for the correct process. Then, the experiments can be done accordingly to the machining cutting path strategies. There are seven (7) cutting path strategies are being used for this project. The patterns of cutting paths are shown in Figure 2.



**Fig. 2. Machining cutting methods in Mastercam software**

The research tool MasterCam X MR2 software will generate code to CNC (Computer Numerical Control) milling machine. This computer holds memory register storing a various of routine that are efficient of manipulating logical functions generate by MasterCam X MR2 software. Then, the machining can be finished accordingly to the machining cutting path strategies.

### B. Experimental equipment and set up.

Deckel Maho Evolution 50 High Speed Milling was used for the experiment. The maximum spindle speed that could be achieved by the machine was 18,000 RPM. The surface roughness readings were measured by utilizing a Mitutoyo's Surftest SV-3100. It provides measurement of fine peak, as well as the normal type of surface roughness measurement. The most usual term of surface roughness parameter reading was Ra. Ra is the region between the roughness peak and its mean line, three measurements taken with "cut off" 16 mm lengths were made for each sample, then an average value was calculated. The experiment run by using Deckel Maho – DMU 50 eVo Linear, was the high speed milling machine available at advanced machining shop in UniKL IPROM. It was arranged to prepare a suitable entry-level apparatus for machining trial with 3-axis machining and CAD/CAM systems which mean suitable for code that has been generated by MasterCam X MR2 software.

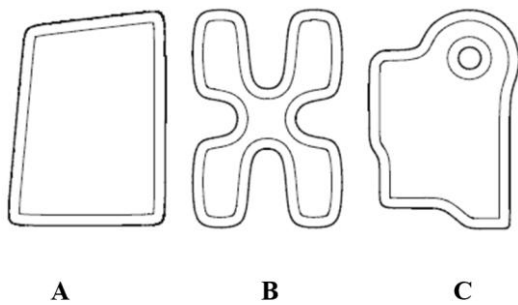


The workpieces, made up of Mould Steel DF2 provided and the machining tool used is four-flute solid carbide end mill. Tool path strategies, pocket geometry and cutting parameters is generated by MasterCam X MR2 software make the running process easier to run in sequence based on design of experiment (DOE) method, generated by Minitab software.

Minitab is an excellent tool for both Confirmatory Analysis and Exploratory Data Analysis. Its wide use in the Industry, Business environments and University speaks for its favour in terms of both constancy and ease of use [10]. Minitab's built-in with an assist that helps in execute Design of Experiment (DOE) that will simply discovered which factors and interactions affect the process

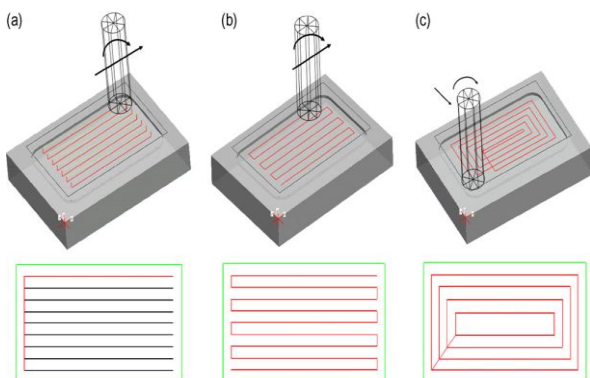
**C. Experimental Procedure**

Figure 3 shows the three pocket geometries used in this experiment which were extracted from [11]. The result between this experiment and past research by [11] will be compared. The pocket shapes are chosen based on the followings: pocket A is a non-symmetric closed convex curve; pocket B is a two axes symmetric non-convex curve; pocket C is a non-symmetric closed curve with an interior island.

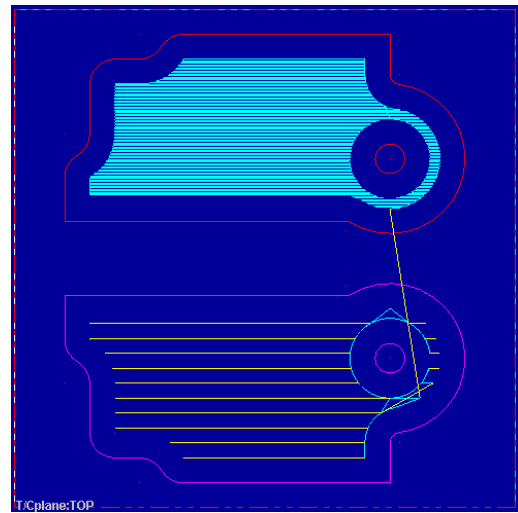


**Fig. 3. Three pocket geometries used in experiment.**

The cutting path strategies employed in the experiment, which is the One direction, Zigzag and Parallel Spiral is shown in Figure 4 [4]. The tool path was generated using the MasterCam X MR2 machining station as shown in Figure 5. Shape and dimensions of stock and tool, as well as the machining condition such as the feed rate, spindle speed and depth of cut, were also included into the software.



**Fig. 4. Cutting path strategies; a) one direction; b) Zigzag; c) Parallel Spiral.**



**Fig. 5. Tool path generation created by MasterCam X MR2 software.**

NC code was generated by CATIA was examined and simulated before dispatch it to the machining core. After the machining processes, the transversal and longitudinal surface roughness was measured with the Mitutoyo's Surftest SV-3100. The run order of the experiment, shown in Table 1, was generated using Minitab.

**Table- I: Experimental run order**

Standard Order	Run Order	Toolpath Strategy	Pocket Geometry
5	1	Parallel Spiral	C
9	2	One Direction	C
8	3	One Direction	A
7	4	Zigzag	A
6	5	Zigzag	B
4	6	Parallel Spiral	A
2	7	Zigzag	B
3	8	One Direction	C
1	9	Zigzag	A

The sample of workpiece will be crafted with pocket milling, which is an another form of end milling used to mill shallow pockets into flat parts after removing all the material inside some random closed region on a flat surface of a workpiece to a fixed depth. The result of Ra measurements were taken 3 times for each runs and then averaging it. Than the sample will be trimmed by grinding process every time the sample was involved in Ra measurements. The results from the Mitutoyo's Surftest SV-3100 is quantifies as roughness average (Ra) and will be analyze in the Minitab software in form of graphical analysis. The effectiveness of different tool path strategy and pocket geometry is evaluated in form of surface roughness will be generated. The analysis generated is based on a factorial experiment, designed to study the effect of two or more factors, each of which is applied at two or more levels. It also can be used to study how a response variable is influenced by certain factors which mean the response variable able to investigate the influence of tool path strategies and pocket geometry on surface roughness in pocket milling of mould steel.



# Influence of Tool Path Strategies and Pocket Geometry on Surface Roughness in Pocket Milling

## III. RESULT AND DISCUSSION

The result data entered into the Minitab software to generate a graph of response (surface roughness) in various form of graphical analysis. All 9 runs were measured to get the surface roughness (Ra) data. By using the data, the pattern of graphs can be classified. The standard for Ra were been set the lowest is better than the highest. Means that lowest Ra is recognized as good quality surface.

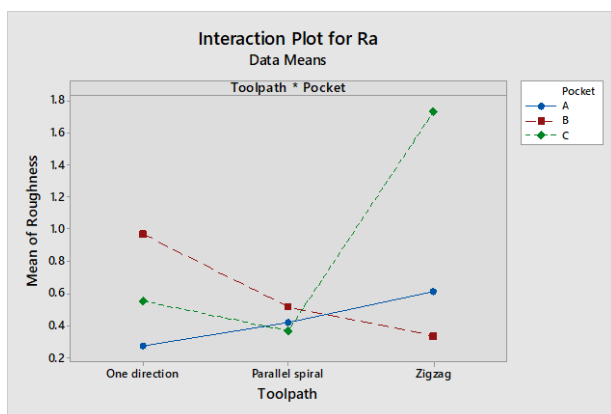
The relations between different tool path strategy and pocket geometry on surface roughness of mould steel DF2 can be determined from the Ra measurement from experimental result. Besides that, individual plot graph of surface roughness of each factors (tool path strategy and pocket geometry) will be discussed thoroughly on the effect against the response factor (surface roughness, Ra).

The graphs more clearly to interpret each of the graphical patterns and so the decision can be make which setting are known as optimum machining parameters includes tool path strategies and pocket geometry to get the better surface roughness, Ra. The optimum parameter can be use it in the industry practice purpose.

Table 2 shows the measured surface roughness, Ra for all nine experiments. The lowest surface roughness reading was obtained for Pocket A with One direction cutting path strategy about 0.271. The highest surface roughness reading was obtained for Pocket C with Zigzag cutting path strategy 1.734.

**Table- II: Experimental run order**

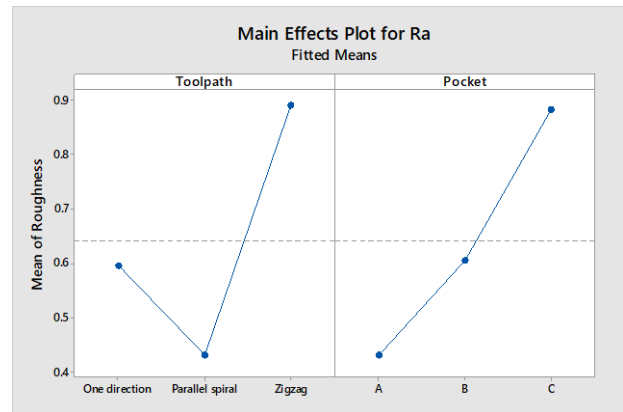
Std. Order	Run Order	Toolpath Strategy	Pocket Geometry	R <sub>a</sub>
1	1	One direction	A	0.271
9	2	Zigzag	C	1.734
3	3	One direction	C	0.551
8	4	Zigzag	B	0.333
4	5	Parallel spiral	A	0.414
6	6	Parallel spiral	C	0.365
2	7	One direction	B	0.969
7	8	Zigzag	A	0.609
5	9	Parallel spiral	B	0.514



**Fig. 6. Interaction plot for Ra**

From interaction plot graph above (Figure 6) shows two (2) things. First the toolpath strategy of parallel spiral response (Ra) was lower in value than the other 2 toolpath strategy which is lower than 0.6. The other is oocket geometry A are most lower Ra produce than the other pocket geometry

B and C that shows all the result is lower than 0.609. There are strongly proves from main effect plot for Ra below (Figure 7) that the toolpath strategy parallel spiral and pocket geometry A are lower in value of Ra for experimental results conducted.



**Fig. 7. Main effect plot for Ra**

The results obtained from the experiment show lowest Ra value was recorded by one direction strategy with pocket geometry A, and for Zigzag strategy, the highest Ra was recorded with pocket geometry C. This experimental result concludes that the type of pocket geometry affect Ra value.

In relation to surface roughness, pocket A and pocket B, transversal and longitudinal roughness is lower than 0.65  $\mu\text{m}$  for any tool path strategy as shown in Figure 5 and Table 3. This trend coincides with one presented by [11]. (2013) for UNS A96063 alloy. The Ra is highest in pocket C (refer Figure 5), due to the presence of islands (refer to Figure 1), which distorts the path of the cutting tool [11]. The influence is also depending on the size and shape of the island contours and workpiece, and the size of cutter used [1]. The results of comparison show that the finest tool path strategies is dependent on the geometry of the part, the type of the used tool paths, the machine characteristics, and cutting conditions. In general there is no specific tool path type that can be used for the same machine for all workpieces (Elkeran et al., 2006).

## IV. CONCLUSION

A The finding of this research able to conclude that the Parallel Spiral strategy yields lowest Ra measurements, which is about 0.43  $\mu\text{m}$  for various type of pocket geometry and had higher precision to produce fine surface roughness based on experimental results (refer Figure 5). Furthermore, in terms of pocket geometry, pocket geometry A produced lowest Ra value in this experiment. In relation to surface roughness, it can be concluded that pocket A and B produced fine surface roughness than pocket geometry C. It has been found that tool path pattern has significant influence on surface roughness. Although, the trend from past researches by using high speed milling in experiment activities involves in much metal removal proven to achieve fine surface finished. Through this experiment, show that the adequate choice of tool path strategy to milling a specific geometry can improve the surface roughness in terms of lowest Ra..

## ACKNOWLEDGMENT

The authors would honor to thanks to Universiti Kuala Lumpur (UniKL) Malaysia Italy Design Institute (MIDI) for financial and technical supports which facilitated the equipment in the successful completion of this work.

## REFERENCES

1. Elkeran, A., El-Midany, T. T., & Tawfik, H. (2006). Toolpath Pattern Comparison: Contour-Parallel with Direction-Parallel . *Geometric Modeling and Imaging--New Trends*, 06, 77 - 82.
2. Krar, S. F., & Gill, A. (2011). *Technology of machine tools* (7th ed.). New York, NY: McGraw-Hill.
3. Toh, C.K., 2004. A study of the effects of cutter path strategies and orientations in milling. *J. Mater. Process. Technol.* 152, 346–356.
4. Gologlu, C., & Sakarya, N. (2008). The effects of cutter path strategies on surface roughness of pocket milling of 1.2738 steel based on Taguchi method. *Journal of Materials Processing Technology*, 206(1–3), 7-15.
5. Wang, M.Y., Chang, H.Y., 2004. Experimental study of surface roughness in slot end milling AL2014-T6. *Int. J. Mach. Tools Manuf.* 44, 51–57.
6. Chartakom, S. & Butdee, S. (2008). Journal of Achievements in Materials and Manufacturing Engineering. *Experiment on High Speed Machining Parametres for Sport Shoe Sole Mold Making Using Aluminium Alloy 5083, 6163 and 7075*, 31(2), 307-307. Retrieved from Papers\_vol31\_2/31221.pdf.
7. Gokler, M.I., Ozanozgu , A.M., 2000. Experimental investigation of effects of cutting parameters on surface roughness in the WEDM process. *Int. J. Mach. Tools Manuf.* 40 (13), 1831–1848..
8. ASSAB DF-3. (n.d.). *DF3\_Brochure*. Retrieved March 4, 2014, from [http://assabmalaysia.com/DF3\\_Brochure\\_090619\\_Ed.pdf](http://assabmalaysia.com/DF3_Brochure_090619_Ed.pdf).
9. Shamsuddin, K. A., Ab - Kadir, A. R., & Osman, M. H. (2013). A Comparison of Milling Cutting Path Strategies for Thin-Walled Aluminium Alloys Fabrication. *The International Journal Of Engineering And Science (IJES)* , 2(3), 01-08.
10. Ganesh, S. (1997). Software review: A review of Minitab – Release 11. *Journal of Applied Mathematics and Decision Sciences*, 1(1), 73-78.
11. Romero, P., Dorado, R., Díaz, F., & Rubio, E. (2013). Influence of Pocket Geometry and Tool Path Strategy in Pocket Milling of UNS A96063 Alloy. *Procedia Engineering*, 63, 523-531.

## AUTHORS PROFILE



**M.Z.A. Yazid** is Associate Professor in Manufacturing Section at Universiti Kuala Lumpur-Malaysia Italy Design Institute, Kuala Lumpur, Malaysia. He receives his Master of Science in Engineering Business Management and Ph.D. in Mechanical and Materials Engineering, from University of Warwick, United Kingdom and Universiti Kebangsaan Malaysia,

Selangor, Malaysia, respectively. His research areas include Mechanical Properties, Corrosion, Machining, and Materials. A recent publication is “Environmentally friendly approaches assisted machining of aluminum alloy 7075-T6 for automotive applications: a review”.



**Second Author Munzir Razak** is currently work towards Master of Engineering Technology (Manufacturing) in Universiti Kuala Lumpur-Malaysia Italy Design Institute, Kuala Lumpur, Malaysia. He holds a Bachelor of Engineering Technology in Manufacturing Systems in 2015 from Universiti Kuala Lumpur - Institute of Product Design and Manufacturing. He is a Registered Engineering Technologist under Board of Engineer Malaysia (BEM). His research mainly focuses in Metal Cutting, Machining, Cutting Tools, and Coolant Techniques. He is carry out research to develop sustainable and health concern machining processes, which are environmentally friendly and harmless to the operators.