

# Performance Analysis of Subcarrier Multiplexed Optical Transmission System for QPSK Data

Rajesh Goel



**Abstract:** This paper focuses on the impact of different parameters on the performance of the Subcarrier Multiplexed Optical Transmission System for the application on radio link via optical fiber. Performance results are evaluated for QPSK data format for ODSB and OSSB modulation of Microwave subcarriers with digital NRZ coded random data patterns. The four subsystems of QPSK modulators are at 400, 500, 600, 700 MHz subcarrier frequencies with frequency spacing of 100 MHz. The power of subcarriers is decreasing with increasing the link distance due to dispersion and attenuation. By using dispersion compensation fiber, the link distance has been enhanced from 100 km to 240 km successfully. The impact of chromatic dispersion has been reduced in OSSB by using dual-electrode MZM. The constellation diagram also confirms that the phase of the signal after traveling through the link is changing due to dispersion. The phase is the same for subcarrier 600 MHz & 700 MHz for ODSB and OSSB in QPSK SCM. The impact of linewidth and responsivity on SNR has also analyzed to evaluate the performance. It is concluded that the maximum SNR is decreasing with increase in the linewidth of laser source and increasing with the increase in responsivity of PIN diode for the same fiber length in SCM transmission.

**Keywords :** Eye Diagram, SCM, ODSB, OSSB, QPSK,

## I. INTRODUCTION

Optoelectronics is an emerging technology that combines electronics with optics and forms the backbone of information-based communication & signal processing technologies. The use of optical fibers for information transmission has become so popular, and a number of fiber-optic telecommunication networks have been installed throughout the world. As the need for longer and longer unrepeatable transmission distance and ultra-fast broadband transmission increases, the advanced transmission technique has to be investigated. So, it is the pressing demand of the future to examine the feasibility of the unrepeatable transmission and ultrafast broadband transmission over long distances both theoretically and experimentally.

So the focus of today's research is to provide a way to tap the vast capacity potential available in the optical channel because the available optical communication system is not utilizing bandwidth. The current hybrid fiber/ co-axial (HFC) architecture and WDM networks have limitations with regards to bandwidth, data rates and cannot cater to next-generation bandwidth demands and crises.

Moreover, this HFC architecture creates bottlenecks in the last mile of the local access. To get rid of the bottleneck, the fiber cable has to reach all the way to customers' premises that can support triple play i.e. voice, video and data. Next, the utmost demand of the operators is to have enormous bandwidth that can support integrated services and future-proofing, because the capital cost of installing a local access network is very high. So the next generation network, the truly first data-oriented broadband network supporting broadband media services will be all IP, meaning all access to the network will be via IP standards. There had been much research on multiplexing techniques with emerging optical fiber communication technology. The researches on Sub-Carrier Multiplexing (SCM) were focused on the fiber modes, types of detection schemes, interference, noises and overall performances evaluating signal to noise ratio (SNR). SCM, in combination with WDM, can be used to exploit the full amount of the enormous fiber bandwidth. Therefore, the bandwidth efficiency in SCM, as compared to conventional optical WDM, is anticipated to be far better [1-8]. The hybrid optical fiber/ co-axial architecture has the potential to cater to the limitations of the current CATV System architecture and explored the performance for the optical portions of that system. The performance of high-speed digital fiber optic transmission using SCM, both analytically and numerically, has been analyzed [9]. The data rate of 20 Gb/s was successfully transmitted through SCM optical link and BER is less than  $10^{-9}$  for a link loss of 29.5 db with excellent performance over 82 km of DCF, this system can support transmission over multiple spans [10]. A technique of Optical Single Sideband (OSSB) to reduce the impact of chromatic dispersion and to enhance bandwidth efficiency as compared to ODSB is successfully demonstrated by many researchers [11-12]. The fiber link distance can be increased by using the external modulators either MZM or EA and by varying the chirp parameter of the modulator using dual-electrode MZM. [13-15].

Manuscript received on May 25, 2020.  
Revised Manuscript received on June 29, 2020.  
Manuscript published on July 30, 2020.

\* Correspondence Author

**Rajesh Goel**, Secretary, Haryana State Board of Technical Education (HSBTE), Panchkula-134107, Haryana, India. E-mail-[goelrajesh17@gmail.com](mailto:goelrajesh17@gmail.com)

© The Authors. Published by Blue Eyes Intelligence Engineering and Sciences Publication (BEIESP). This is an [open access](https://creativecommons.org/licenses/by-nc-nd/4.0/) article under the CC BY-NC-ND license (<http://creativecommons.org/licenses/by-nc-nd/4.0/>)

# Performance Analysis of Subcarrier Multiplexed Optical Transmission System for QPSK Data

Keeping in view the above-discussed research, the focus of this paper is to study an approach using Subcarrier Multiplexing Transmission technique that can provide the huge bandwidth and gratify the demands of the future network with better performance than the existing networks with much simple complexity of the system design and easy to install and maintain. The link established for SCM transmission is driven by four carriers and performance is investigated by modulating the carriers with QPSK data formats and system performance is investigated for both ODSB and OSSB modulation technique for various parameters. Dispersion compensation fiber is incorporated to reduce the signal degradation due to accumulated dispersion and to increase the link distance.

## II. SIMULATION SET-UP

Here Figure-1 demonstrates the layout of the QPSK SCM link for (a) ODSB (b) OSSB transmission link:

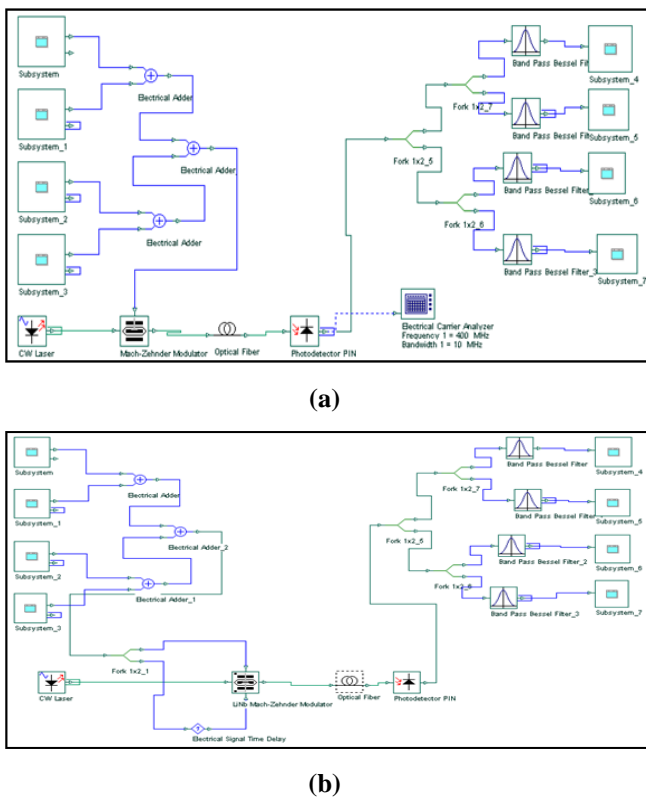


Figure -1: QPSK SCM Transmission Link (a) ODSB (b) OSSB

### A. QPSK Modulator

As shown in Figure-1, the subsystems at the input side of the link are QPSK modulator. The four subsystems are QPSK modulators at 400, 500, 600, 700 MHz subcarrier frequencies with frequency spacing of 100 MHz. The internal layout of the subsystem as a QPSK Modulator is shown in Figure-2.

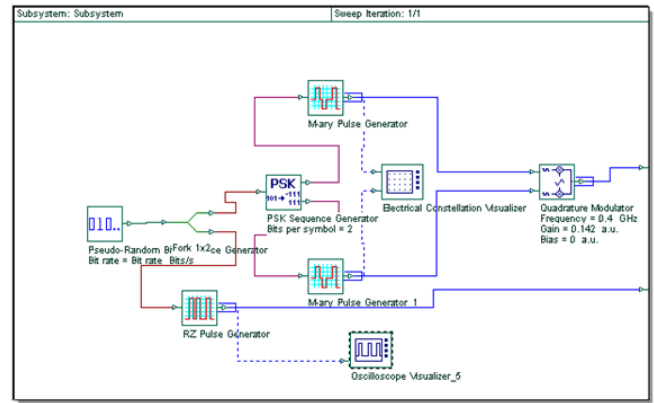


Figure-2: QPSK Modulator

The Pseudo Random Bit Sequence Generator (PRBS) generates the sequence of bits at a bit rate of 26 Mb/s. This bit sequence drives the PSK Sequence generator that is using two bits per symbol for generating the PSK sequence. Then after passing the sequence from M-ary's, this drives the quadrature modulator whose carrier frequency is set at 400, 500 600 and 700 MHz for each modulator, and at the output of each modulator, we get the QPSK modulated data at each subcarrier frequency. The QPSK modulated signal of all the modulators is added and a composite spectrum is obtained as shown in Figure-4(a)

### B. Optical Transmitter

This composite frequency spectrum received at the output of QPSK modulator (Figure-4 (a)), is given to the MZM along with the laser source at 193.1 THz or 1550 nm and the linewidth of 10MHz. The optical carrier modulates the RF spectrum according to the type of the modulator used. If the MZM is a single electrode, then there is double sideband modulation, and if MZM is dual electrode, then single sideband modulation is there, as shown in Figure.-3(b) and (c) respectively. The optically modulated signal is launched in the optical fiber of length 10 km (Initially). The other various parameters for optical fiber for simulation set up are: Fiber loss  $\alpha = 0.2$  dB/km; Reference wavelength =1550 nm; Fiber Dispersion =16.75 ps/nm-km; non linear refractive

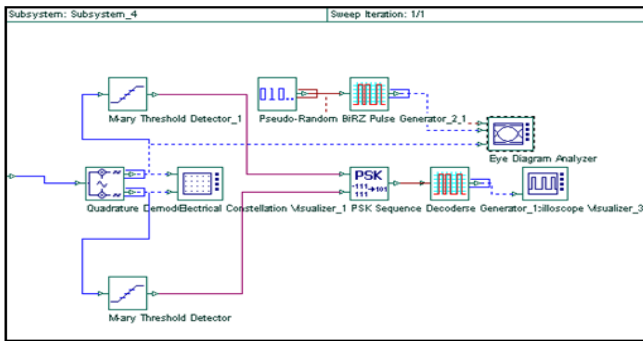
$$\text{index } n_2 = 2.6 \times 10^{-20} m^2 / W \text{ and } A_{eff} = 60.31 \mu m^2$$

### C. Optical Receiver

The optical signal received by the Photodetector is converted into the electrical signal. The received RF spectrum is shown in Figure-4(a) double sideband (b) single sideband. This spectrum consists of all the four frequencies that were transmitted along with the optical carrier. Now, these RF carriers carrying the data are first separated into individual carriers along with data by passing the RF spectrum through the Bandpass Filter (BPF). So four BPS filters are used to separate the RF carriers and the center frequency of each filter is set at the carrier frequency with a bandwidth of 50 MHz. After separating the RF carriers, the next job is to extract the data from it. This is done with the help of QPSK demodulator.

**D. QPSK Demodulator**

The subsystems at the output end of the link are QPSK demodulators (Figure-3), and the four demodulators are at a different frequency to demodulate the baseband signal from the carrier. The RF carrier, along with data drives and the Quadrature demodulator is set at the same carrier frequency as that of the input signal. This demodulates the signal and baseband signal is recovered. After passing the signal through M-ary's and PSK sequence generator, that is also using the two bits per symbol for generating the bit sequence. Hence, the original bit sequence is obtained as seen by the oscilloscope visualizer.



**Figure -3 QPSK Demodulator**

The eye pattern at the output is observed with an Eye Diagram Analyzer. That is driven by quadrature demodulator, PRBS with bit rate equal to bit rate divided by 2 and RZ sequence generator. The eye patterns are taken for all subcarriers frequencies and the impact of variation of parameters is observed.

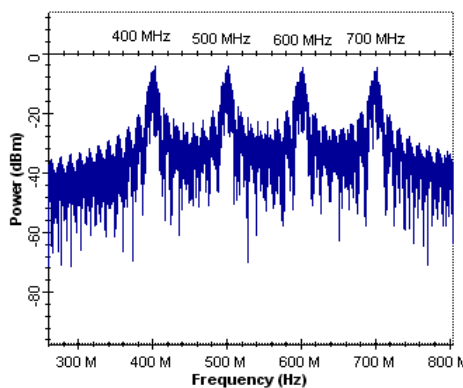
Similarly, the constellation diagram is observed at the output of the quadrature demodulator with the help of electrical Constellation visualizer.

**III. RESULTS AND DISCUSSION**

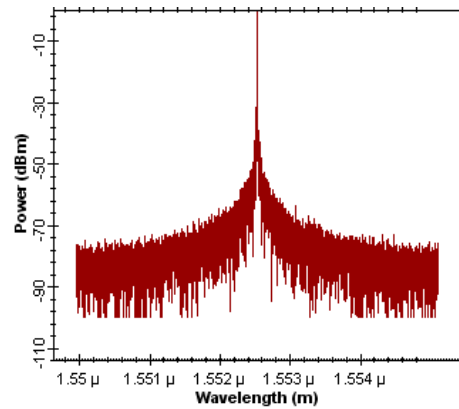
The results have been obtained with the initial fiber length of 10 km for QPSK SCM transmission link for ODSB and OSSB.

**A. QPSK SCM Modulation and Detection**

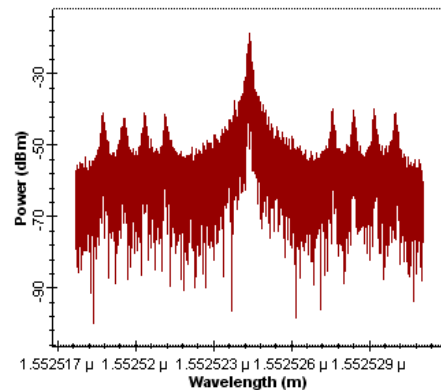
Figure-4(a) demonstrates the modulation of PRBS data at 26 MB/s with the RF subcarriers at 400, 500, 600 and 700 MHz. This composite signal is given to the MZM modulator along with the optical carrier to get the modulated signal depending upon the type of MZM used in Figure-3(c) & (d) ODSB and OSSB, respectively.



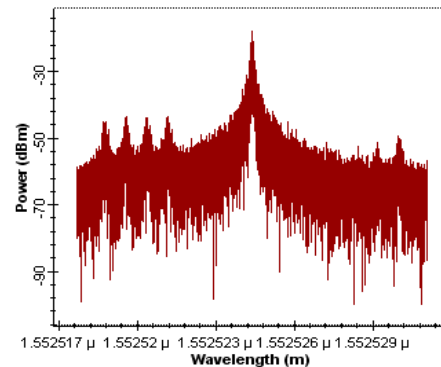
(a)



(b)



(c)

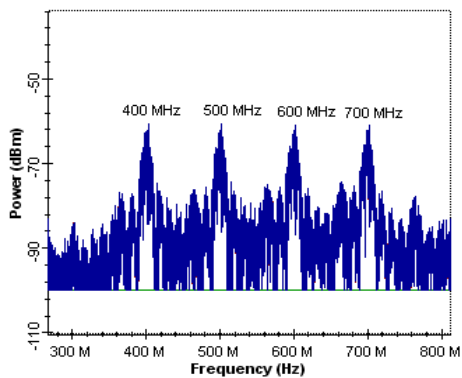


(d)

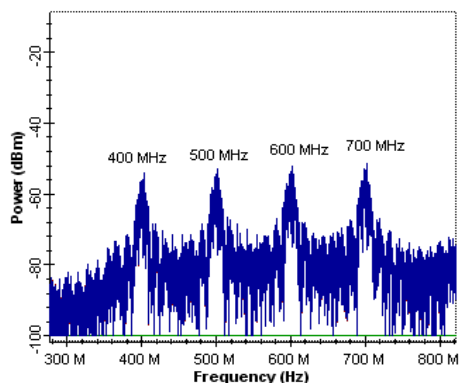
**Figure-1: (a) QPSK Modulation with four RF subcarriers at 400, 500, 600, 700 MHz (b) Optical carrier at 193.1 THz (c) ODSB (d) OSSB**

The QPSK modulated signal in Figure-3(a) & (b) is launched into the optical fiber with length 10 km (initially) and the optical signal is detected and converted to the electrical signal by the Photodetector as shown in Figure-5(a) ODSB (b) OSSB. The detected subcarriers are at same frequency as that of input subcarriers and the spectrum of ODSB and OSSB is same. The signal power is degraded due to accumulated dispersion and fiber loss. The power of the subcarrier at the output is -60dBm as against input power level at about -5 dBm (Figure-4(a)). The four detected RF subcarriers are then separated by using BPF at the center frequency as that of subcarrier.





(a)



(b)

Figure--2 Detected RF carriers at Photodetector (a) ODSB (b) OSSB

The individual RF carrier after the BPS filter is given to the corresponding QPSK demodulator that is at the same carrier frequency. Here the detected signal is demodulated and the baseband signal is recovered.

**B. Eye Pattern**

An eye diagram is commonly used when evaluating electrical and optical data transmission. This pattern is created by superimposing the just opposite 101 and 010 signals as shown in the Figure-6.

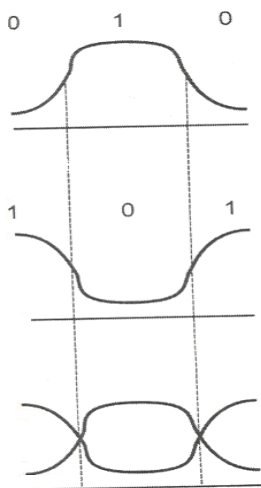


Figure -3: Formation of Eye Pattern

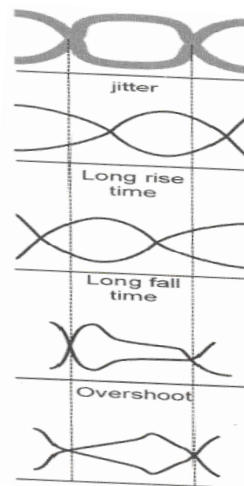
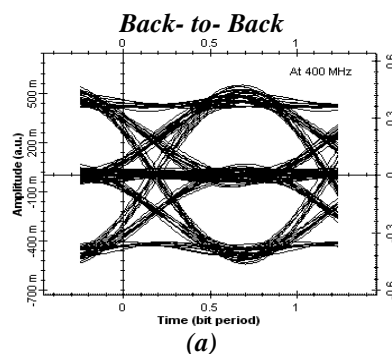


Figure -4: Eye diagram degradation

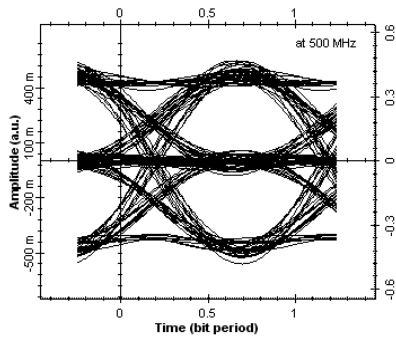
The word eye is used because obtained pattern is very similar to open human eye. The opening of eye can be degraded because of common transmission error as shown in Figure-7. For example, 'jitter' is a minor change in the digital signal regarding reference time, which disperses the signal by increasing the rise time or fall time that closes the eye, it is also possible due to the phenomenon of overshoot and undershoot that distorted the shape. So we can say that the eye pattern indicates the integral behavior and quality of transmission. The eye diagrams at the output of QPSK demodulator are observed with BER analyzer. In the Figure-8(a)-(d) shows the eye diagrams of the back-to-back transmission link for exact data recovery at 400, 500, 600, 700 MHz.

As illustrated, eye-opening in the back-to-back link is maximum. Figure-8(e)-(h) & (i)-(l) shows when the ODSB and OSSB transmission is used between the QPSK modulator and the demodulator. Similarly, eye diagrams are taken at the same frequencies as that in back to back, for both the cases. The fiber length considered in both the case is 10 km. Due to the transmission from the fiber link, there is the degradation in the eye pattern due to dispersion and fiber losses. In Figure-8(e) & (h) for ODSB, the opening of the eye is more for 400 and 600 MHz frequencies than the other two frequencies. But in Figure-8 (j) & (l) for OSSB, the opening of the eye is more for 500 and 700 MHz. than the other two frequencies.

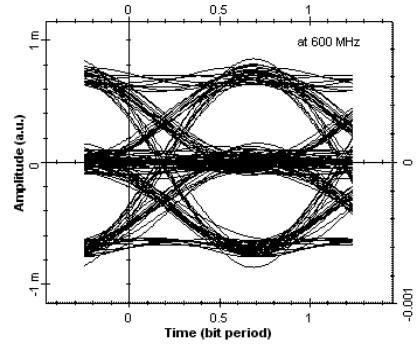


(a)

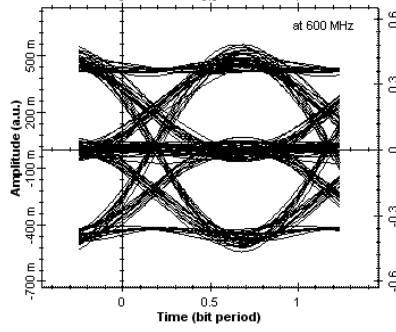




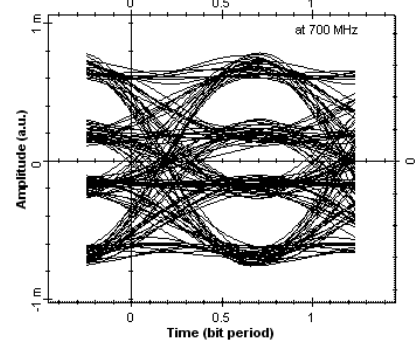
(b)



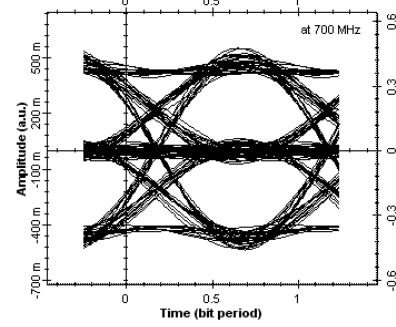
(g)



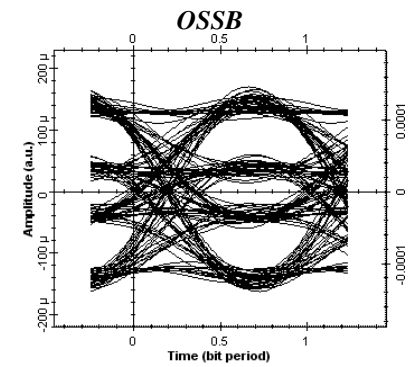
(c)



(h)

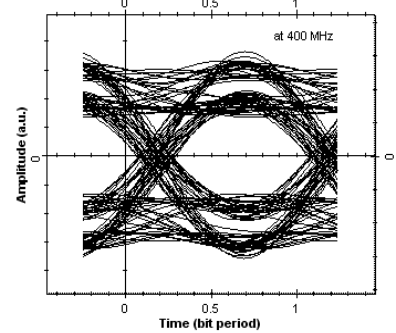


(d)

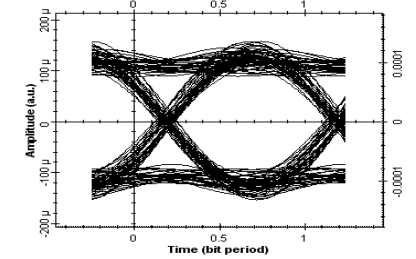


(i)

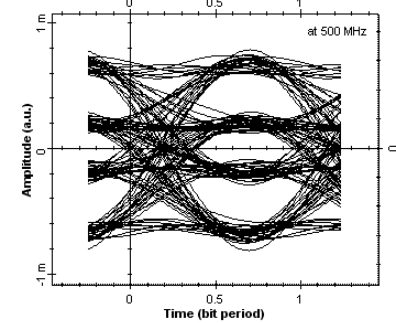
**ODSB**



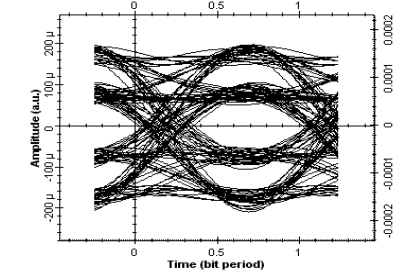
(e)



(j)



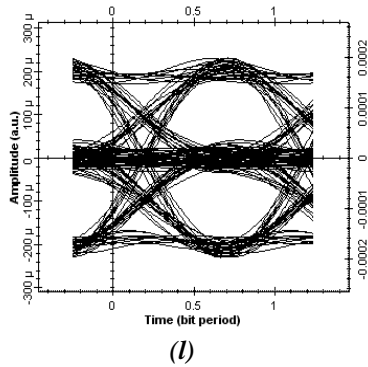
(f)



(k)

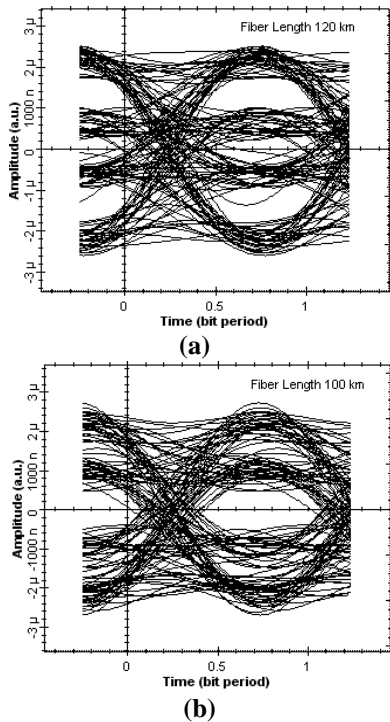


# Performance Analysis of Subcarrier Multiplexed Optical Transmission System for QPSK Data



**Figure -8: The Eye Patterns QPSK SCM Transmission Link (a)-(d) Back-to-Back (e)-(h) ODSB (i)-(l) OSSB**

As the fiber length is increased, the eye pattern is degrading. The Figure-9(a) illustrates the eye pattern of ODSB at length 120 km and (b) eye pattern for ODSB at length 100 km for subcarrier at 400 MHz, beyond these distances, the eye pattern is totally degraded because of the accumulated dispersion and attenuation of the fiber length. So we can say that this is the maximum link distance without any dispersion compensation technique.



**Figure -9: Degradation of the Eye Pattern with the increase in fiber length, the carrier is at 400 MHz. (a) ODSB (b) OSSB**

As we apply the dispersion compensation technique. The eye patterns are very much improved and link distance is increased. As discussed in the next section, the impact of incorporating the Dispersion Compensation Fiber (DCF) in the transmission link.

### C. Dispersion compensation Fiber

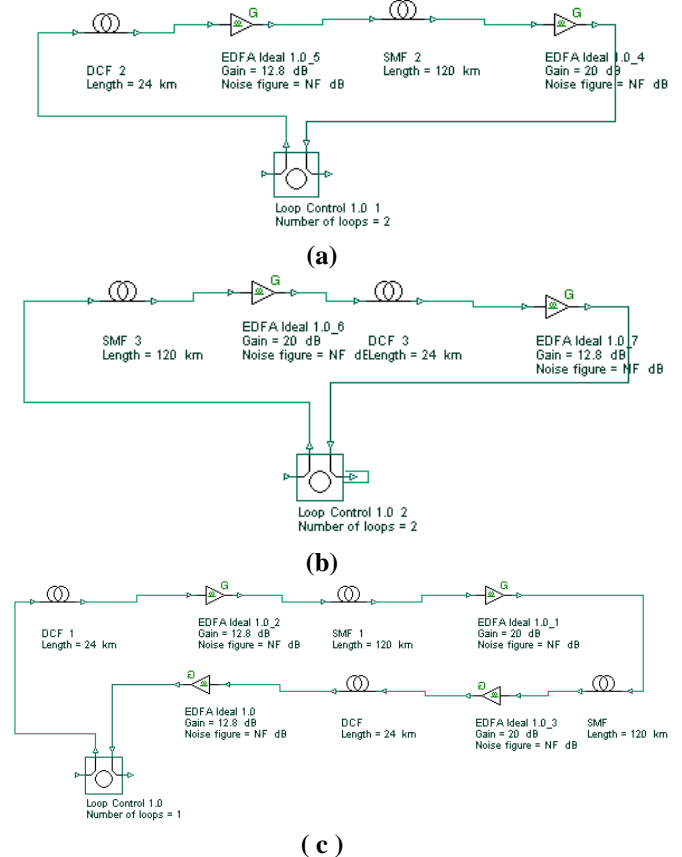
In this experiment, the dispersion compensation scheme is used to improve the system performance. The signals in the adjacent bit periods overlap with each other because of the broadening of the pulse due to chromatic dispersion; this is known as intersymbol interference (ISI). Broadening of the

pulse depends on the link distance as well as dispersion parameter  $D$ . For externally modulated sources, transmission link distance limited by chromatic dispersion and is determined by equation (1):

$$L < \frac{2\pi c}{16|D|\lambda^2 B^2} \quad (1)$$

A number of techniques, including Dispersion Compensating Fiber or Fiber Bragg Grating, can be used to compensate the accumulated dispersion in the fiber. In this experiment Dispersion Compensating Fiber in three different schemes, pre, post, and symmetrical compensation have been used to compensate the fiber dispersion. Pre, Post, and symmetrical compensation configurations are shown in Figure-10. In simulations, optical amplifiers have been used after each fiber to compensate for the span loss. The dispersion parameter of SMF is 120 km long and 16 ps/nm-km. Therefore, total accumulated dispersion is  $16 \times 120 = 1920$  ps/nm that can be compensated by using a 24 km long DCF with - 80 ps/km-nm dispersion.

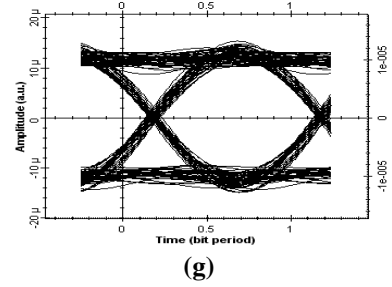
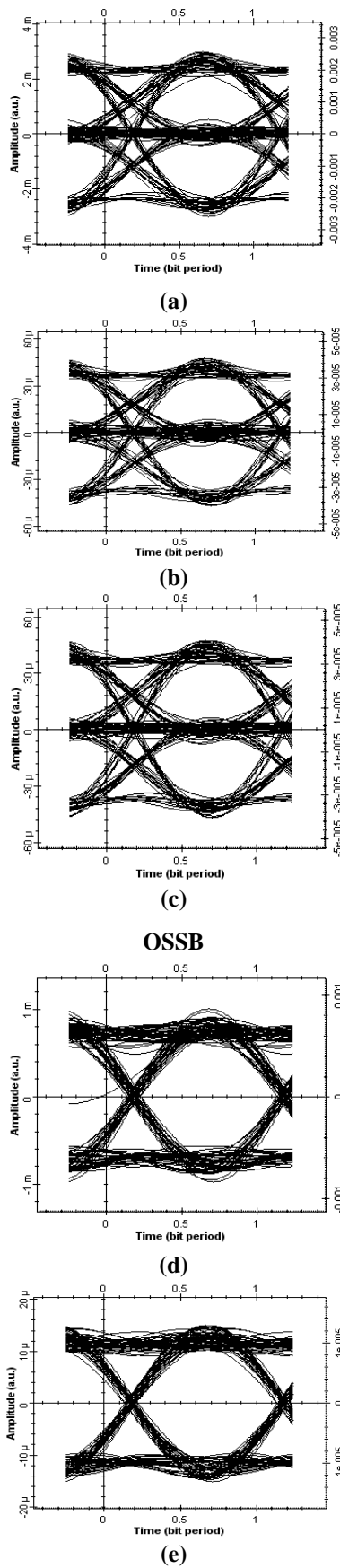
The total transmission distance is  $120 \times 2 = 240$  km for each case. In the post- compensation case, DCF is placed after SMF. In the symmetrical compensation case, fiber placement follows the sequence of SMF, DCF, DCF and SMF.



**Figure -10: Dispersion compensation Techniques (a) Pre- (b) Post (c) Symmetric**

ODSB

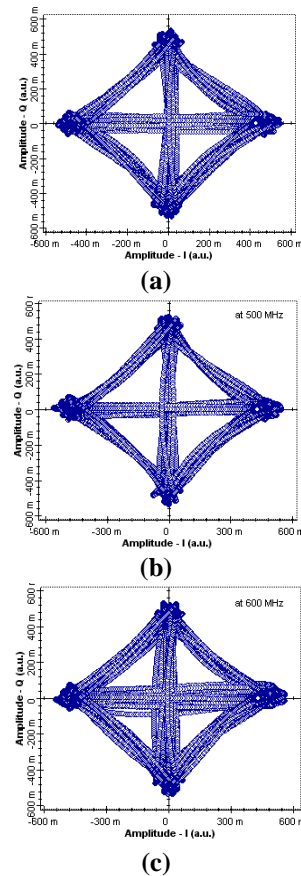




**Figure -11: Eye Pattern with Dispersion compensation fiber, length 240 km, carrier at 400 MHz (a)-(c) ODSB (d)-(g) OSSB (a) & (d) Pre (b) & (e) Post (C) & (g) Symmetric**

Figure-11 shows the eye diagram obtained for the signal at 400 MHz for both types of modulation technique ODSB as well as OSSB with Pre, Post and Symmetric dispersion compensation fiber. By incorporating the DCF, the link distance is increased and the improved opening of the eye clearly indicates the enhanced transmission quality. The eye pattern is degraded at the fiber length of 120KM and 100KM for OSDB and OSSB, respectively, as shown in Figure-9 but by incorporating the DCF the accumulated dispersion is compensated and transmission link distance is increased. It has also been observed from the Fig.-11 that the eye opening is more in case of OSSB with the application of DCF of fiber length 240 km as compared to ODSB.

**D. The Constellation Diagram**



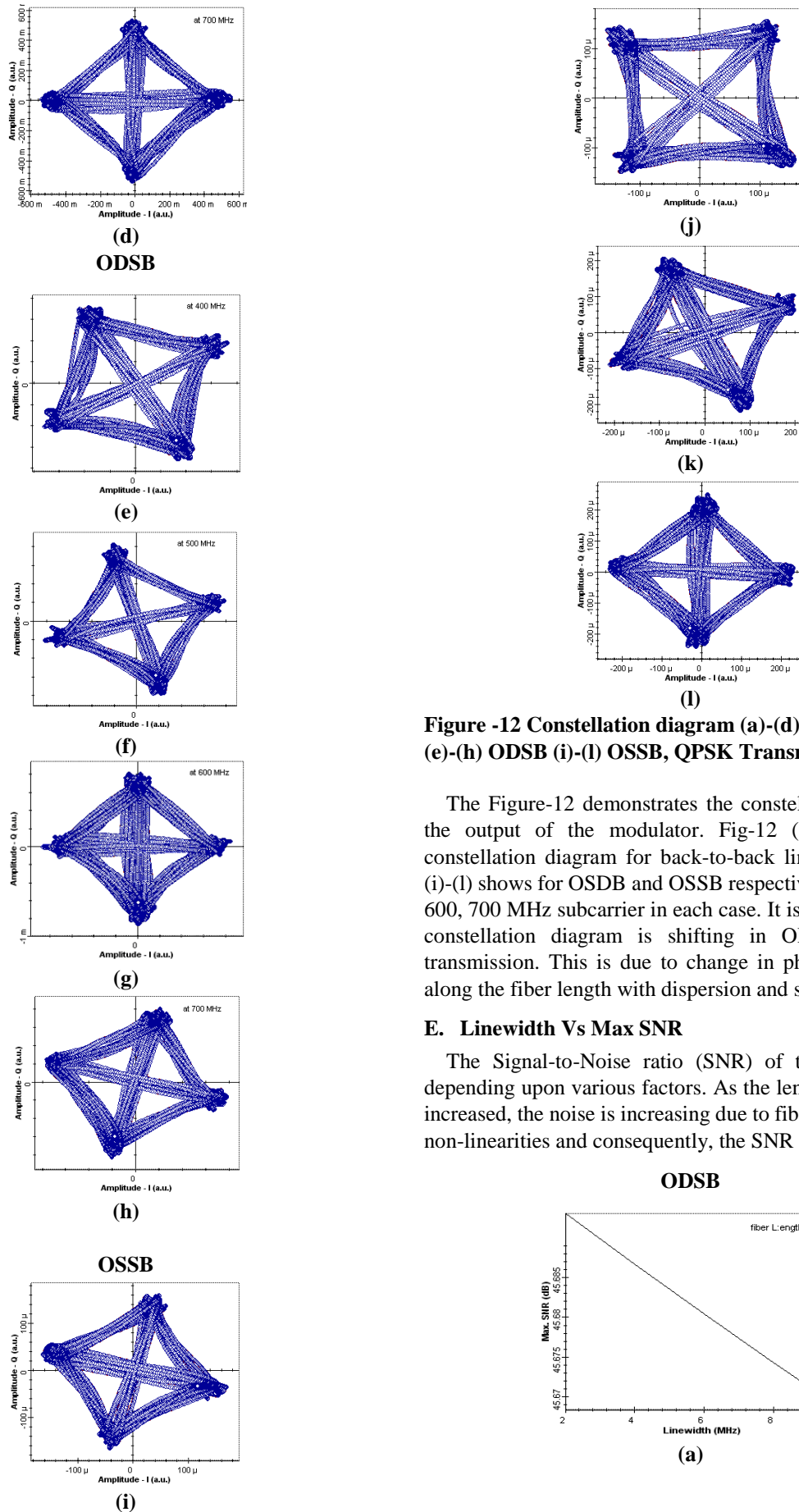
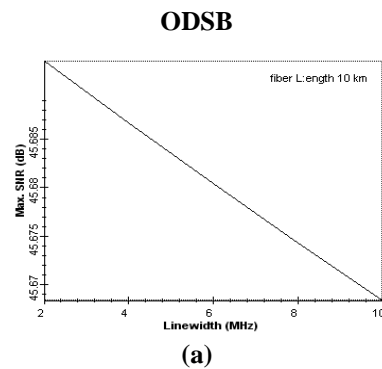


Figure -12 Constellation diagram (a)-(d) Back to Back (e)-(h) ODSB (i)-(l) OSSB, QPSK Transmission Link.

The Figure-12 demonstrates the constellation diagram at the output of the modulator. Fig-12 (a)-(c) shows the constellation diagram for back-to-back link, and (e)-(h) & (i)-(l) shows for ODSB and OSSB respectively, for 400, 500, 600, 700 MHz subcarrier in each case. It is observed that the constellation diagram is shifting in ODSB and OSSB transmission. This is due to change in phase of the signal along the fiber length with dispersion and span loss.

**E. Linewidth Vs Max SNR**

The Signal-to-Noise ratio (SNR) of the subcarriers is depending upon various factors. As the length of the fiber is increased, the noise is increasing due to fiber losses and fiber non-linearities and consequently, the SNR is decreasing.





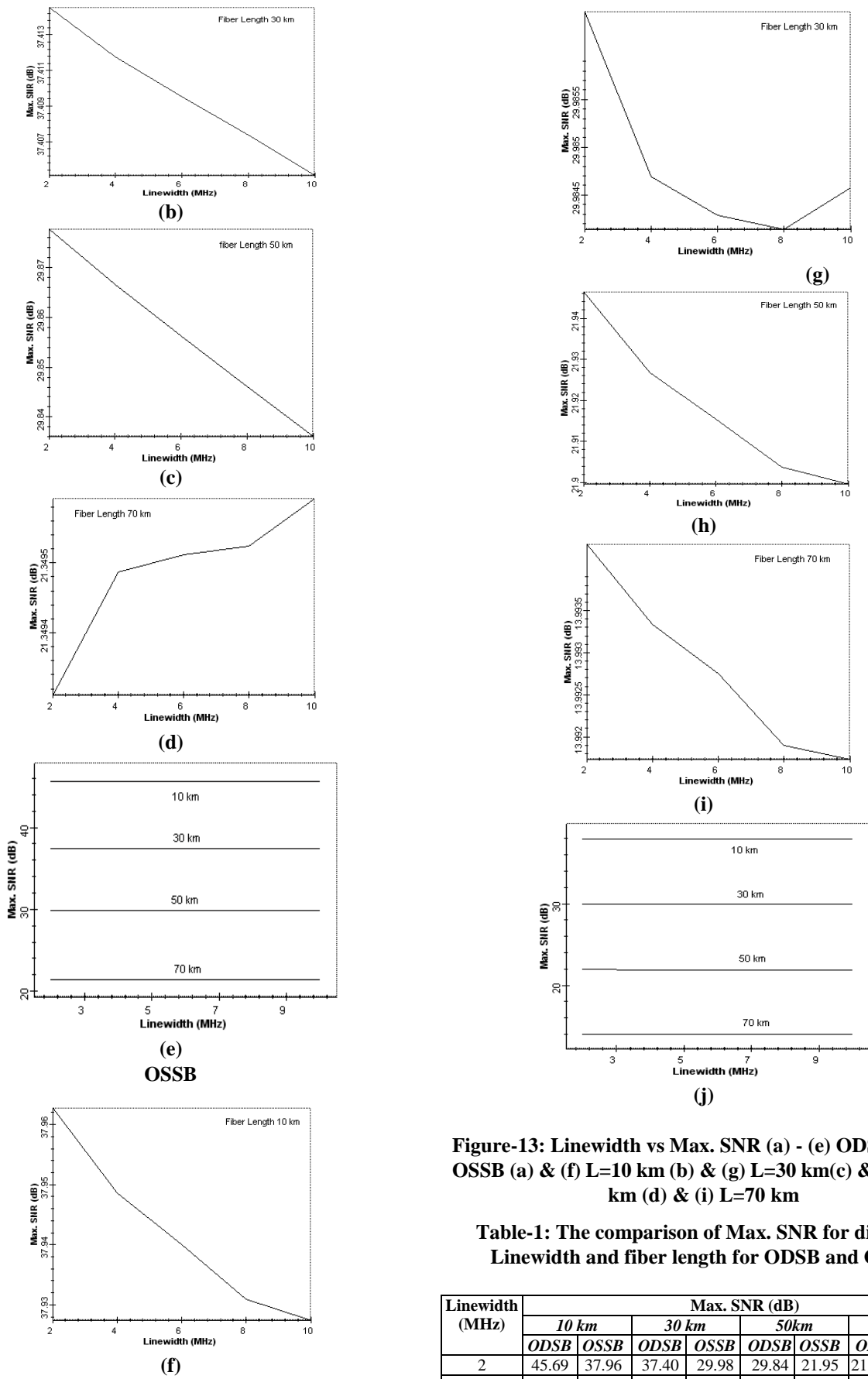


Figure-13: Linewidth vs Max. SNR (a) - (e) ODSB (f) - (j) OSSB (a) & (f) L=10 km (b) & (g) L=30 km (c) & (h) L=50 km (d) & (i) L=70 km

Table-1: The comparison of Max. SNR for different Linewidth and fiber length for ODSB and OSSB

Linewidth (MHz)	Max. SNR (dB)							
	10 km		30 km		50 km		70 km	
	ODSB	OSSB	ODSB	OSSB	ODSB	OSSB	ODSB	OSSB
2	45.69	37.96	37.40	29.98	29.84	21.95	21.3493	13.99
10	45.67	37.93	37.41	29.98	29.88	21.90	21.3496	13.99

Similarly, when the linewidth of the Laser source is increased, the SNR decreases. Max. SNR (dB) is measured for the one subcarrier at 400 MHz with an electrical carrier analyzer at the output of the Photodetector. The linewidth is varied from 2 to 10 MHz. and Max SNR is observed for different values of fiber length. Figure-13 and Table -1 shows that the Max. SNR is decreasing in the both ODSB and OSSB in QPSK SCM Transmission Link.

## F. Responsivity Vs Max SNR

In both the transmission links, the responsivity of the PIN diode is varied from 2 to 10 A/W and Max. SNR is measured at the output of the Photodetector with an electrical carrier analyzer for different fiber lengths.

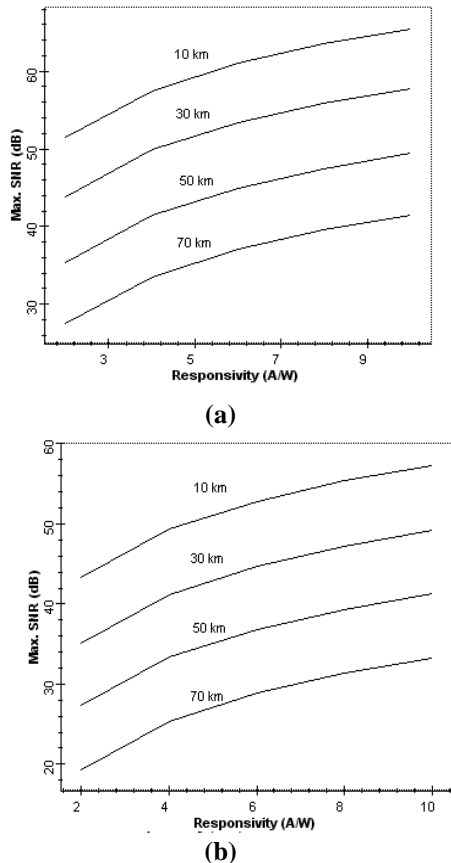


Figure -54: Responsivity vs Max. SNR (a) ODSB (b) OSSB

It has been observed that the Max SNR increases with the increase in responsivity for different fiber lengths ODSB and OSSB in the same manner as shown in Figure-14. So the change in fiber length is immaterial. It seems that more responsivity is required for better SNR at any fiber length

It has also been observed that the SNR is higher with carriers only as compared to when the data is sent and it increases from 54.5 dB to 67 dB and 46.5 dB to 56 dB for ODSB and OSSB respectively. For QPSK data formats, the SNR increases from 53 dB to 64 dB and from 43.5 dB to 58 dB for ODSB and OSSB, respectively.

## IV. CONCLUSION

The SCM transmission link performance is analyzed by sending the QPSK data formats for both types of modulation technique ODSB as well as OSSB. The data rate of 26 Mbits/s is transmitted at four different carrier frequencies of

400, 500, 600 and 700 MHz with a fiber length of 10 km. The eye diagrams are used to analyze the quality of transmission. The eye opening is more for 400 & 600 MHz carrier in ODSB and for 500 & 700 MHz carrier in OSSB for QPSK data format. To reduce the chromatic dispersion and increase the bandwidth efficiency, optical single sideband may be used. There is degradation in the eye pattern with increasing the link distance has been observed because of accumulating dispersion and fiber loss. The data is transmitted successfully up to 100 Km without using dispersion-compensating technique.

By incorporating dispersion compensating fiber (DCF), transmission quality has been improved and link distance is increased up to 240 km observed by more opening of the eye pattern. The only loss is due to attenuation along the fiber length that can be overcome by employing EDFA. Similarly, the constellation diagram for all four carriers is observed for single and double sideband. The phase of the signal is shifting as it propagates along the length of the fiber. The shift in phase is compared with the constellation diagram of back to back link. The impact of linewidth and responsivity on OSNR is also analyzed. The linewidth and responsivity are varied from 2 to 10 MHz and 2 to 10 A/W respectively for different fiber lengths. The SNR is decreasing with the increase in linewidth and its increasing in responsivity. So the change in fiber length is immaterial. Hence, the SNR can be increased by increasing the responsivity of the Photodetector and decreasing the linewidth of the laser.

## REFERENCES

1. Adnan Hussein Ali and Alaa Desher Farhood, Design and Performance Analysis of the WDM Schemes for Radio over Fiber System With Different Fiber Propagation Losses, *Fibers* 2019, 7, 19; doi:10.3390/fib7030019
2. Rajesh, Analysis of impact of laser line width and chromatic dispersion on Carrier to Noise Ratio in Radio over Fiber, *International Journal of Recent Technology and Engineering*, ISSN: 2277-3878, Volume-8, Issue-6, March 2020, pp 3969-3972.
3. Md. Shamsul Arefin, Nusrat Tazin, Munsury Rahman and Tajrian Mollick, Performance Evaluation of a SCM Optical Transmission System, *IOSR Journal of Engineering (IOSRJEN)* e-ISSN: 2250-3021, p-ISSN: 2278-8719, Vol. 3, Issue 4 (April. 2013), PP 37-53
4. Arief M., Idrus and S.M. Alifiah, The SCM/WDM system model for radio over fiber communication link, RF and Microwave Conference, IEEE International, pp 344-347, 2-4 December 2008.
5. Md. Shamim Reza, Md. Maruf Hossain, Adnan Ahmed Chowdhury, S. M. Shamim Reza and Md. Moshir Rahman, Performance Evaluation of SCM-WDM System Using Different Linecoding, *Journal of Telecommunications*, Vol. 2, Issue 1, April 2010.
6. Shijun Xiao & Andrew M. Weiner, Four-User ~3-GHz-Spaced Subcarrier Multiplexing (SCM) Using Optical Direct-Detection via Hyperfine WDM, *IEEE Photonics Technology Letters*, Vol. 17, No. 10, October 2005.
7. Cheng Juang, Shaw Tzuu Huang, Chin Yueh Liu, Wei Chung Wang, Tsung Min Hwang, Jonq Juang and WenWei Lin, Subcarrier Multiplexing by Chaotic Multitone Modulation, *IEEE Journal of Quantum Electronics*, Vol. 39, No. 10, October 2003.
8. M.T. Al-Qadah, H.A. Abdul-Rashid, K. Dimiyati, B.M. Ali and M. Khazani, Effect of Optical Beat Interference in SCM/WDM Optical Networks in Presence of FWM, *KMITL Sci. Tech. J.* Vol. 5, No. 3, July-December 2005.
9. Hui R., Zhu B., Huang R., Allen C., Demarest K., and Richard D., (2001), 10Gb/s SCM system using optical single sideband modulation, In proc. OFC'01, Anaheim, CA, March 2001, MM4.

10. Flood E. A., (2002), Demonstration of 20 Gbits/s subcarrier multiplexed transmission system, Electronics Letters vol. 38, no. 9, 25th April 2002.
11. Rajesh, Performance Analysis of Radio over Fiber with ODSB and OSSB modulation techniques using ASK, 64QAM and 8DPSK data, International Journal of Control and Automation, ISSN: 2005-4297 IJCA, Vol. 13, No. 2. (2020), pp. 81-89.
12. Sieben M., Conradi J., Dodds D., Davis B., and Walklin S., (1997), Optical signal sideband (OSSB) transmission for dispersion avoidance and electrical dispersion compensation in microwave subcarrier and baseband digital systems, Electron. Lett., vol. 33, pp. 971–973, May 1997.
13. Smith G. H., Novak D. and Ahmed Z., (1996), Optimization of link distance in fiber-radio systems incorporating external modulators, in Proc. Australian Conf. Opt. Fiber Technol., Gold Coast, Australia, Dec. 1996, pp. 141–144.
14. Smith G., Novak D., Ahmed Z., (1997), Overcoming Chromatic-Dispersion Effects in Fiber-Wireless Systems Incorporating External Modulators, IEEE Transactions on Microwave Theory and Techniques, vol. 45, no. 8, Pages 1410-1415, August 1997.
15. Woodward Sheryl L., Senior member IEEE, and Phillips Mary R., Member IEEE, (2004), Optimizing Subcarrier Multiplexed WDM Transmission Links, Journal of Lightwave Technology, vol. 22, no.3, March, 2004.

### AUTHORS PROFILE



**Rajesh**, was born on May 4, 1976. He received the Ph.D. (Electronics and Communication Engineering) degree from I.K.G. Punjab Technical University, Jalandhar (India) in 2020.

Presently, he is working as Secretary in Haryana State Board of Technical Education (HSBTE), Panchkula Haryana (India). He has around 15 years of experience in the installation, operation and maintenance (IO&M) of Optical Fiber Communication Systems in Bharat Sanchar Nigam Limited (BSNL). His research interests are optical fiber communication and synthesis, characterization and application of polymers, block copolymers, polymer thin films, organic-inorganic composite and nanocomposite materials