

Evolutionary Algorithm Technique to Optimize Configurational Cost in Reconfigurable Manufacturing System

Suresh Babu G, N. Chikkanna

Abstract-In past few decades, manufacturing industry has been trying to achieve the high quality customized products in the flexible batches. Moreover due to the dynamic demand of market, the product lifecycle and flexibility is one of the major concern and Reconfiguration Manufacturing System is one of the discovery that matches these criteria such as flexibility, reliability and others, the main advantage of RMS is its adoptability to cope up with change in software and hardware configuration for adjusting the promptly. Hence in this paper we have proposed a optimized RMS , the main objective is to reduce the cost of the configuration through task scheduling, we propose Evolutionary algorithm based approach for configuration, moreover here we find the optimal solution through utilizing the machine over the operation set for each machine part, later we find the optimal from the probable assignment. In order to evaluate the algorithm we have performed the case study, a case study shows that Evolutionary algorithm based approach achieves the optimum solution when compared to the existing.

Keywords: RMS, Evolutionary Algorithm, optimal configuration.

I. INTRODUCTION

Manufacturing world has changed in the last century and has effected dynamically in terms of social and economic circumstances considering the customer requirement over the periods. Manufacturing technologies along with the other paradigm has been introduced for addressing the challenges in response of the social needs. Moreover, in the late 1970s, manufacturing industry from the japan started developing the lean manufacturing principles from then the product quality has been major point, later in same era CNC (Computer Numerical Control) is develops to create the probable manufacturing system that can easily produce the different variety of products on same machine.

In 90s era due to the globalization companies started facing the huge competition, the main problem they were facing is unpredictable market change, huge demand and change in design of the product . These issue made the manufacturing system very difficult to survive as it directly affected the economic scenario of factory and this became major reason for the industry to develop the new manufacturing system that could give the rapid response to the product change, unforeseen market.

Hence in year 1995, a new manufacturing system named as "RMS (Reconfiguration Manufacturing System) was developed by Dr. Koren.

Revised Manuscript Received on February 18, 2020.

Suresh Babu G., Research Scholar, VTU Research Resource Centre, Belagavi, Karnataka, India. E-mail: sureshbabuhere@gmail.com

Dr. N. Chikkanna, Professor, Department of Aerospace propulsion technology, VTU VIAT, Muddenahalli, Chickballapur, Karnataka, India. E-mail: nchikkanna1967@gmail.com

RMS is said to be the opem model architecture, which gives the flexibility to add the machine to already existing operational model with no time. RMS has the several advantages such as rapid response, cost effective [1]. Moreover, the main aim of manufacturing system is rapid response to the market demands, cost effective, modifiable [2].

Moreover RMS combines the advantage of two important concept i.e. dedicated manufacturing lines, [3] and flexible manufacturing system [4]. Moreover DMLs have been designed for the huge production for less cost and possesses high throughput whereas flexible manufacturing system is designed for enabling the production of any given product, however the throughput is marginally less when compared to the DML. Moreover, the Flexible manufacturing system is very much expensive. Moreover, by taking, this into consideration researcher developed the RMS (Reconfigurable Manufacturing System), RMS possesses the unique feature which the other two DML and FMS fails. The throughput of reconfigurable manufacturing system is very much higher than the FMS but lower than the Flexible Manufacturing system, however, the main advantage of RMS over DML is its flexibility. RMS is far more flexible than these two design as Reconfiguration Manufacturing System [5]. Moreover RMS follows six distinctive characteristics which is depicted in the below figure.

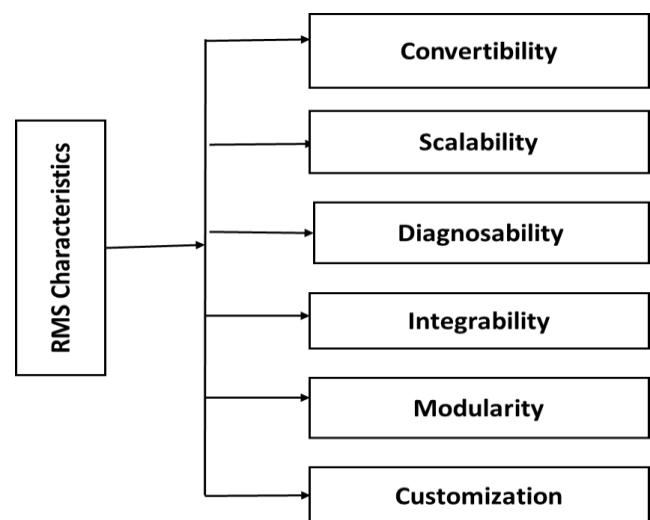

Figure 1: RMS Characteristics

Convertibility is capability of functionality of existing system and fit into the new requirements, Scalability is the capacity to add or remove the resources according to the requirement,

diagnosability is dealing with the real time monitoring of the product and diagnosing immediately by identifying the root cause of the issue. Integrality interprets the integration of the module in rapid manner through hardware and software interface. Modularity means the operational function can be compartmentalized into several units that can be manipulated. Last characteristics is the customization facility provides the flexibility to be customized in the family part. Moreover, a typical Reconfigurable Manufacturing system combines both the CNC and different Reconfigurable Machine tool (RMT), RMT is designed for the particular kind of operation also its specialty is it can be rapidly and easily convertible from the one configuration to the other according to the requirement.

In order to establish the probable configuration, set of operation (SoP) selection and (SoP) set of operation assignment plays major role, *SOP_selection* and *SOP_assignment* are defined mainly on the relation between *SOP(Set of Operation)* and *SOC(Set of Cluster)*. In this research work we propose optimized Reconfigurable manufacturing system is designed in such a way that it optimizes the performance of RMS, Here *SOC(Set of Cluster)* is performed in a particular order for Probable *SOC(Set of Cluster)* sequence, moreover the contribution of the research work is pointed below:

1. It reduces the cost by optimizing the performance.
2. Evolutionary based algorithm is flexible to adopt to understand and it is very much probable.
3. Our research work considered designed for the part family and capable of matching the dynamic environment
4. EA based RMS configuration achieves the optimized configuration of Reconfigurable manufacturing system.
5. EA aims to achieve the economical configuration that can include the optimized and nearer optimized configurations.

This Particular research work is organized in a standard way as any other research work, here first section starts with evolution of manufacturing industry and the need for reconfigurable manufacturing system, last part of the first section gives the contribution of EA based approach for RMS. Second section discuss the various existing methodology for cost optimization, third section describes the EA based approach along with algorithm and mathematical notation. Fourth section discuss the evaluation of EA based approach by considering the case study and various constraint.

II. LITERATURE WORK

Moreover in past several methodologies have been proposed to ensure the optimized the reconfiguration manufacturing system, some of them are discussed here.

In addition, there are many methodologies for verifying the system i.e. reconfiguration manufacturing system to be optimized have been presented by the researchers, here some of these methodologies have been studied. Regarding to the sequence of the parts there is a set of decisions which is to be free into the system as well as there are many tasks which allocated to each and every machine and sequence of that allocated part, the machine pair /operations' selection

[6][7]. In this area, proposed a problem regarding to the optimization models [7]. Mathematical models are described in [8] and it minimizes the make-span. By utilizing the two heuristics such as GA in together with SA the presented models are resolved. [9] acquaints a model which is multi-objective the production scheduling is to be optimized in which the machines' performance along with the capacity are maximized as well as for the system reconfiguration are minimized and these all are required by the costs. Moreover, [10] for the flow lines which are reconfigurable, the scheduling as well as configuration generation problem are integrated and the capital, total tardiness, reconfiguration cost is optimized by the bi-objective model. [11] Into account the multi-configuration nature of RMSs, which is taken, by GA and this GA procedure defined by the IPPS (integrated process planning and scheduling) and this IPPS are tackled in [11]. [12] For a line which is an assembly, a reconfigurable layout is presented here and products which positioning in account reconfiguration effort, due date and profit over the cost scheduling is performed. There are two approach, which are integrated such as reference Ideal Method, as well as Shannon Entropy for scheduling. [13] Based on the study of the RMS, among the alternative solutions, which are probable in manufacturing system and to choose the best optimal manufacturing system, an AHP (analytical hierarchy process) is utilized. For the configurations of the machining system are automatically generated which is explained in GA (genetic algorithm) [14]. For the flow lines, which are homogeneous parallel, an approach known as capacity scalability approach suggested in this work. In this work firstly for all the demand periods pleasing the demand by alternative system configurations which is introduced in this work. After this as to selection of initial point at single period configuration introduced in this work. [15] for reasons by which causes defects in final product, to diagnose and to detect there is one technique known as diagnosability this technique is proposed in [15] as well as the defects are rectified quickly by using this technique. [16] For the configuration of the various systems' convertibility in together with productivity as a system performance have been studied here. In terms of responsiveness, an accurate measurement is given by this. There are various modules by which modular machine is composed as machine tools which are re-configurable, these tools have been developed here. There many combinations of auxiliary module as well as basic modules in RMTs. By modifying the auxiliary modules / adding and removing and by positioning base module, the RMTs can reconfigure into the other configurations. At the time of reconfiguration there are many selection processes but the selection of the appropriate configuration recommended by the scheduling which consist in RMS. In the hardware as well as software components for earlier rapid change, a state-of-the-art manufacturing system is designed this is scheduling problems in configurable manufacturing system. There are problems and those total problems will be divided in the sub problems described in this work. Those sub-problems are machine or operation selection as well as input sequencing. There are different techniques recommended here in manufacturing system for the input sequencing.

III. PROPOSED METHODOLOGY

1.1 Input

Investment: In order to design the configuration, the initial budget is set through the management according to the budget.

MI : Maximum Initial investment allowed

Space: In order to configure the machine, space is allocated which includes the width and length; it is given by the system designer. Moreover, the length is considered as the amount of storage location and width is considered as the parallel machines in the workstations.

MP_{max} : Maximum amount of Parallel machine needed

ML_{max} : Maximum number of available locations

Initial information of machine: In case of each operation Set, some of the initial information is required such as type of the machine, initial cost. Moreover, the machine capacity is known through the number of task performed by machine.

M : Set of machine available

DR : Depreciation rate for the given machines

m : Machine type index, $m = 1, \dots, |M|$

I_m : Initial Cost of machine

$\mathbb{O}_{k,m}$: Operation Set which can be performed with the m machine type for the k part.

$Z_{\mathbb{O}_{k1},m}$: Operation set with , m machine type for the part 1

$T_{\mathbb{O}_{k1},m}$: in case if operation set \mathbb{O}_{k1} can be performed by the m machine type then $T_{\mathbb{O}_{k1},m}$ depicts the time else $T_{\mathbb{O}_{k1},m}$ is considered to be the infinity.

$min_{\mathbb{O}_{k1},m}(\mu_k)$: This indicates the minimum machine with the m type is required to perform \mathbb{O}_{k1} under given capacity μ_k for k part

Machine capacity can be defined as the ability to perform the number of task assigned in unit time; capacity μ_k is achieved through the cycle time given which requires the machine to complete the given task for k . Moreover cycle time can be achieved from DR (Demand Rate) \mathcal{D}_k , in here les consider $\mathcal{D}_k = \mu_k$ and the $T_{\mathbb{O}_{k1},m}$ is time, here time depicts the whole time i.e. operation time, setup time.

$$min_{\mathbb{O}_{k1},m}(\mu_k) = T_{\mathbb{O}_{k1},m} \cdot \mu_k \quad (1)$$

Operation Information: while designing the structure, the operation on the each part should be given, also the relation between the operation set and cluster has to be defined. Clusters and operations are recognized in the operation part types.

S_k : All operation set for the k part

C_k : Cluster set for the k part

\mathbb{O}_k : set of operation set for the k part

C_{k1} : 1 The cluster for the k part, $\{1 = 1, \dots, |C_k|\}$

$\mathbb{O}_{k1} = 1$ the operation set for part P , $\{1 = 1, \dots, |O_k|\}$

CG_k : Conflict graph for k part

$\mathcal{R}_{C_{k1}, \mathbb{O}_{k1}}$: Depicts the relationship among the cluster and operation set

$param_{C_{k1}, \mathbb{O}_{k1}}$: It depicts the binary parameter and the value is said to be unit if C_{k1} includes the cluster which should conflict \mathbb{O}_{k1}

Requirement Scenario: This includes the information about the production area and the requirement.

D : Tenure of the Demand Period (in years)

MP_C : Machine part count i.e. part types

k : Part type index, $k=1, \dots, MP_C$

\mathcal{D}_k : Demand Rate for the k part

1.2 Optimization for distribution

Moreover for the machine utilization distribution over the operation set in case of each part optimization has to be followed

1.2.1 Initialization

Before optimizing the distribution few initialization has to done through the following points.

- All machine should be available with their hundred percent usability.
- Various operation seta of the particular part type or the different part type can assign to the one WS.

In here multiple SOP for the same part has been allowed and assigning various SOP minimizes the cost when compared to the single assignment separately.

1.2.2 Dependent Variable Consideration

Moreover we consider the dependent variable, which controls the decision-making, below are the two dependent variable.

$\mathcal{A}_{p, \mathbb{O}_{k1}}$: This indicates the variable, if operation set \mathbb{O}_{k1} of the part k is assigned for the particular stage p , $\mathcal{A}_{p, \mathbb{O}_{k1}}$ is said to be the value of 1 else zero.

$\mathcal{B}_{p,m}$: This indicates the variable, if machine type r has been assigned to the stage p , $\mathcal{B}_{p,m}$ is 1 else, it is zero.

1.2.3 Problem Definition

Moreover the problem definition can be given through the below equation.

$$\sum_{p=1}^{MP_{max}} \sum_{k=1}^{MP_C} \sum_{m \in M} \mathcal{B}_{p,m} \left[\sum_{\mathbb{O}_{k1} \in \mathbb{O}_k} \mathcal{A}_{p, \mathbb{O}_{k1}} min_{\mathbb{O}_{k1},m}(\mu_k) \right] I_m (1) - ((1 - DR)^D PVF), \quad (2)$$

The above equation minimizes the CC (Capital Cost) of the configuration, here PVF is Present Value Factor and computed through the below equation

$$PVF = \frac{1}{(1 + AUR)^D} \quad (3)$$

AUR is the interest rate observed yearly, moreover there are several constraint related to this problem, equation 3 presents the constraints set, the below equation makes sure that selected operations set have all the clusters for the each part and out of these clusters, each cluster is assigned to the single stage.

$$\sum_{p=1}^{MP_{max}} \sum_{\mathbb{O}_{kl} \in \mathbb{O}_k} \mathcal{R}_{C_{lk}, \mathbb{O}_{kl}} \mathcal{A}_{p, \mathbb{O}_{kl}} = 1, \quad \forall k=1, \dots, MP_C \quad (4)$$

Below equations shows the dependency relation among the operation set and it guarantees of the constraint that one operation doesn't start until one gets over.

$$\sum_{p=1}^{MP_{max}} \mathcal{A}_{p, \mathbb{O}_{kl}} \cdot \sum_{p=1}^{MP_{max}} p(\mathcal{A}_{p, \mathbb{O}_{kl}} - \mathcal{A}_{p, \mathbb{O}_{kl}}) \geq 0, \quad \forall k = 1, \dots, MP_C \quad (5)$$

Similarly, equation 6 gives the guarantee of all operation set assigned to the stage p can easily performed through the machine types, which is assigned to the stage p .

$$\sum_{k=1}^{MP_C} \sum_{\mathbb{m} \in \mathbb{M}} \mathcal{A}_{p, \mathbb{O}_{kl}} \leq \sum_{k=1}^{MP_C} \sum_{\mathbb{O}_{kl} \in \mathbb{O}_{k\mathbb{m}}} \mathcal{B}_{p, \mathbb{m}} \mathcal{A}_{p, \mathbb{O}_{kl}} \quad \forall p=1, \dots, MP_{max} \quad (6)$$

Equation 7 guarantees that at each stage, maximum machine type is installed, furthermore equation 3 to equation 7 presents as the constraint function.

$$\sum_{\mathbb{m} \in \mathbb{M}} \mathcal{B}_{p, \mathbb{m}} \leq 1, \quad \forall k = 1, 2 \dots, MP_{max} \quad (7)$$

Equation 8 restricts the number of parallel machine i.e. ML in each stage.

$$\sum_{k=1}^{NP} \sum_{\mathbb{m} \in \mathbb{M}} \mathcal{B}_{p, \mathbb{m}} \left| \sum_{s_j, i \in S_j} \mathcal{A}_{p, \mathbb{O}_{kl}} \min_{\mathbb{O}_{kl}, \mathbb{m}}(\mu) \right| \leq ML, \quad \forall p=1, \dots, MP_{max} \quad (8)$$

$$\sum_{p=1}^{MP_{max}} \sum_{k=1}^{MP_C} \sum_{\mathbb{m} \in \mathbb{M}} \mathcal{B}_{p, \mathbb{m}} \left| \sum_{\mathbb{O}_{kl} \in \mathbb{O}_{k\mathbb{m}}} \mathcal{A}_{p, \mathbb{O}_{kl}} \min_{\mathbb{O}_{kl}, \mathbb{m}}(\mu_k) \right| \phi_{\mathbb{m}} \leq MI \quad (9)$$

Equation 9 is the cost constraint function which helps to restrict the investment in given budget, equation 10 and 11 are the two constraint for the decision making variable.

$$\mathcal{A}_{p, \mathbb{O}_{kl}} \in \{0, 1\}, \quad \forall p = 1, \dots, MP_{max} \quad (10)$$

$$\forall k = 1, \dots, MP_C$$

$$\forall l = 1, \dots, |\mathbb{O}_k|$$

$$\mathcal{B}_{p, \mathbb{m}} \in \{0, 1\}, \quad \forall p = 1, \dots, MP_{max} \quad (11)$$

$$\mathbb{m} \in \mathbb{M}$$

Choosing $\min_{\mathbb{O}_{kl}, \mathbb{m}}(\mu_k)$ with the machine type r helps in satisfying the capacity of production for operation set \mathbb{O}_{kl} . Moreover, the above equation formulates the programming model where multiple operation set of the given same part can be assigned for the single stage in the model.

1.3 Optimization based on evolutionary approach

Moreover in the above approach we observed that the constraints are over complicated and highly improbable to handle, here the most complicated is equation 4 and equation 5, hence we find the probable operation set y i.e. *probable SOP* among whole *SOP* and later we also find the suitable operation set partition of the *probable SOP*. Once the equation 4 and equation 5 are satisfied we achieve *Probable_assignment*.

Reconfigurable manufacturing system are capable of executing all the *SOP*, hence the equation 6 and 7 gets satisfied, moreover if equation 8 and equation 9 are satisfied then the configuration is probable

1.3.1 Evolutionary approach

Since it is observed that we deal with the NP-Hard problem which is considered for the configuration generation of RMS, the best approach is the evolutionary approach, here the main aim is to achieve the best optimal solution.

In this research work, we imply the evolutionary approach for configuration generation issue; hence, the idea is to develop the encoding and decoding method along with constraint managing method. Moreover, it's easier to identify the optimal configuration once the probable operation set is known. Hence, in here we mainly focus on the encoding and decoding part. Moreover to imply the EA approach configuration has to be optimal which is solved through the below algorithm.

1.3.2 Optimized configuration Algorithm

In this subsection-optimized configuration algorithm is proposed for identifying the optimal configuration, here first it tries to find the probable solution, if the probable solution is missing then the configuration that possesses the minimum cost is identified.

Moreover given probable *OP_assignment* mean that *SOP* assigned in the particular Workstation is accessible, hence to for multiple *SOP*, lets compute the capacity requirement through the below equation.

$$CR_{\mathbb{m}p} = \left[\sum_{k=1}^p T_{\mathbb{O}_{kl}, \mathbb{m}} * CR \right] \quad (12)$$

Hence, to find optimal configuration, a machine has to be identified that has the minimum cost in workstation, to achieve that we have designed *optimized_configuration_algorithm*.

optimized_configuration_algorithm

Step1: start
Step2: Identify the operation set by checking the p th workstations
Step3: Identify the type of machine which can perform all the assigned operation set in the
Step4: Compute the minimum machine for each machine type in case of each WS(Work stations) assigned
Step5: Cost computation of corresponding machine for workstations assigned Cost is
Step6: Identify the machine that has minimum cost
Step7: compute the minimum cost of each WS(Workstations)
Step8: End

1.4 Finding the best optimal solution

1.4.1 Probable SOC(Set of Cluster) identification

By taking advantage of relation among the probable SOP and probableOP_assignment, we find the probable SOC(Set of Cluster)

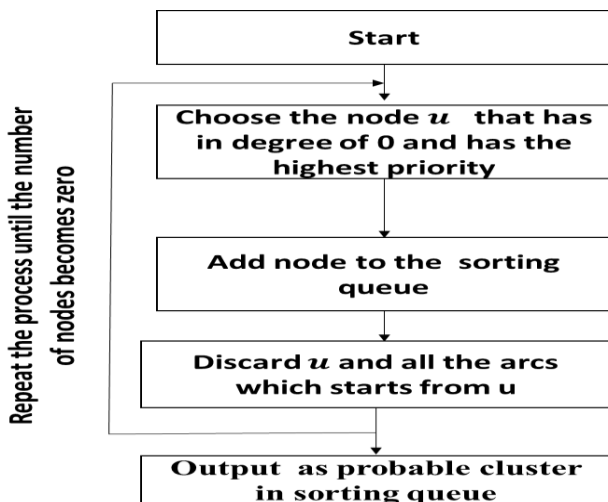

Figure 2 Probable SOC identification

Once probable SOC is achieved, EA tend to achieve the probable OP_assignment through the below Algorithm.

1.4.2 Probable OP_assignment

Step1: start

Step2: scan the chromosome component

Sub step A: achieve the probable operation cluster through the above process for the left part

Sub step B: middle part should be scanned and in case of the chosen operation set, place it for the operation clusters.

Sub step C: In case of each left operation cluster, replace these by single operation set and achieve the probable operation set.

Sub step D: In case of each operation set in probable operation set, identify the assigned stage ID of the right part

Step 3: check if any component is left in chromosome, which has not been scanned.

Step4: Empty stage elimination

Step5: output as probable operation cluster

Step6: Stop

1.5 Optimized Evolutionary algorithm

Let's consider *Maximum_Run* and *IND_POP* be the two variable which denotes the run generation and the individual population respectively. *Parent(i)* and *child(i)* be the parent and child population, where *i* indicates the generation and at last consider *POM* and *POC* be the probability of mutation and Probability of Crossover, then the evolutionary algorithm for optimization is given below.

Step1: start

Step2: Initialization of *IND_POP*, *Maximum_Run*, *POM*, *POC*, $i = 0$;

Step3: Generation of random population

Step4: Compute the fitness function

Step5: For $ind = 1$ to $IND_POP / 2$

Sub step 5.1: Selecting the two entity ind_e and ind_f from the *Parent(i)* generated population by Fitness proportionate selection.

Sub step 5.2: crossover ind_e and ind_f and produce ind_r and ind_s

Sub step 5.3: mutate ind_r and ind_s

Sub step 5.4: Compute both fitness ind_r and ind_s

Sub step 5.5: End the for loop

Step6: Ranking of the individuals according to their fitness

Step7: Choosing the distinctive and best individuals

Step8: $i = i + 1$

Step9: Repeat step 5, step6, step 7 and step8 until $i = Maximum_Run$

Step10: end

IV. RESULT ANALYSIS

In this section, we evaluate EA based approach for optimized configuration of RMS, for evaluation we have considered the standard system configuration. Here Python is used as the programming language on windows platform packed with 8 GB RAM i7 processor.

Case study

In this section of the research work, we have developed case study for the evaluation, moreover to achieve that we have used ANC-101 as a sample part, which is depicted in the figure 3; this has been standard part for the various researcher. ANC-101 has main 14 feature, these features are machined with the given 20 operations [17]. Table 1 presents the various operation and it is represented through the Conflict graph of operation in figure 4.

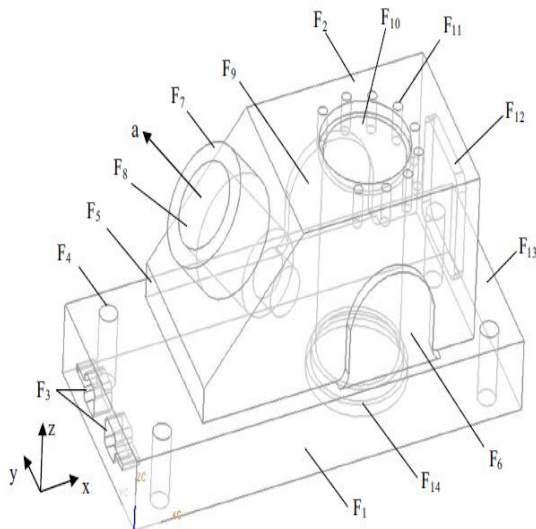

Figure 3: ANC-101 test part

The below table shows Feature, operations and Description, first column represents the features from F1 to F14, Second column represents operation, here OP1, OP2, OP3, OP6, OP7, OP11, OP17 and OP18 are milling operation. Similarly, OP4, OP8, OP12 and OP15 are drilling operation. OP9, OP13 and OP19 are reaming operation. OP10, OP14 and OP20 are Boring operations.

Table 1 Test Condition and criteria

Features	operations	Feature Description
F1	OP1	Planar Surface
F2	OP2	Planar Surface
F3	OP3	Two packets placed in replicated feature
F4	OP4	Four holes placed in replicated feature
F5	OP5	Step
F6	OP6	Protrusion
F7	OP7	Boss
F8	OP9 OP10	Compound Hole
F9	OP11	protrusion
F10	OP12 OP13 OP14	Compound Hole
F11	OP15 OP16	Nine holes placed in replicated feature
F12	OP17	Pocket

F13	OP18	Step
F14	OP19 OP20	Compound Hole

1.5.1 Condition based comparison analysis

Moreover, in order to prove the efficiency, flexibility and robustness of Evolutionary based RMS, our model is evaluated under various condition and these are depicted in the Table 2. Here in first condition it is assumed that all the machine tools are available for operations, whereas in second condition the cost of cutting tool and cutting tool change are ignored and all the other resources are available. Third condition is very dependent on the second condition i.e. it is assumed that in third condition machine cutting edge and machine tool are not available. Moreover, under first condition, the benchmark is 2535, the result obtained by ESGA is 2530, similarly under the second condition the best benchmark result is obtained by and ESGA model also achieves the same whereas our proposed model achieves the optimal result is 2090. Moreover, under the third condition the benchmark achieved is 2590 whereas proposed model achieves the 2488. Moreover, these conditions have been further evaluated by plotting the graph of capital cost versus generated number. Fig 5, Fig 6 and Fig7 shows the graph of capital cost vs number generated. In each graph, two lines are depicted i.e. minimal capital cost and the average capital cost. Here we see that EA based approach performance is at its best.

Table 2 Comparison of existing and proposed model

Conditions	Condition Description	Benchmark Result	Existing System()	Proposed Model(Evolutionary approach)
First Condition	All machine tools are available	2535	2530	2500
Second condition	All the machine and the tools are available cost of the tool and change cost of the tool are ignored for the computation	2090	2090	2080
Third Condition	Unavailability of cutting tool T8 and Machine M2, cost of the tool and any change in the same has been ignored	2590	2590	2488

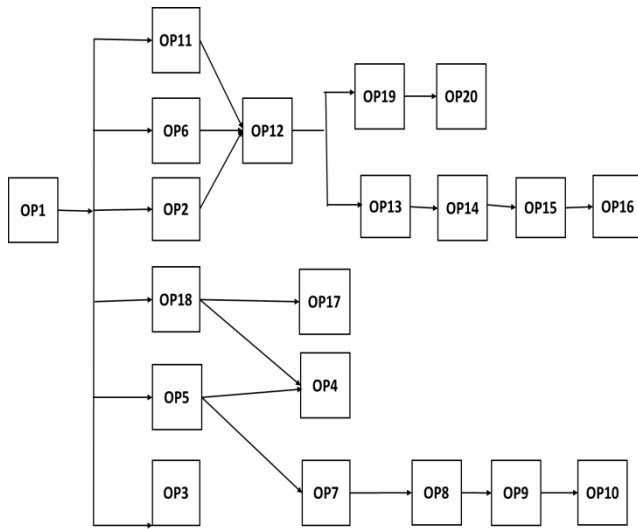

Figure 4: OPG of ANC-part 101

Moreover, Figure 4 shows Conflict Graph of ANC-part 101, moreover the EA based RMS is compared with ESGA.

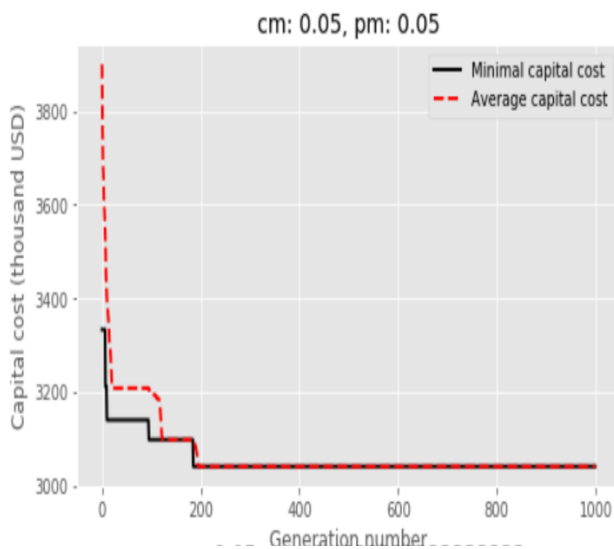

Figure 5: capital cost vs generation number based on the first condition

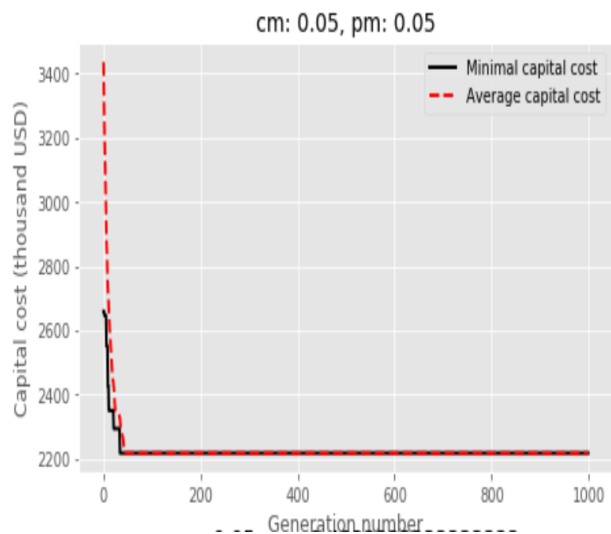

Figure 6: Capital Cost vs Generation Number based on the second condition

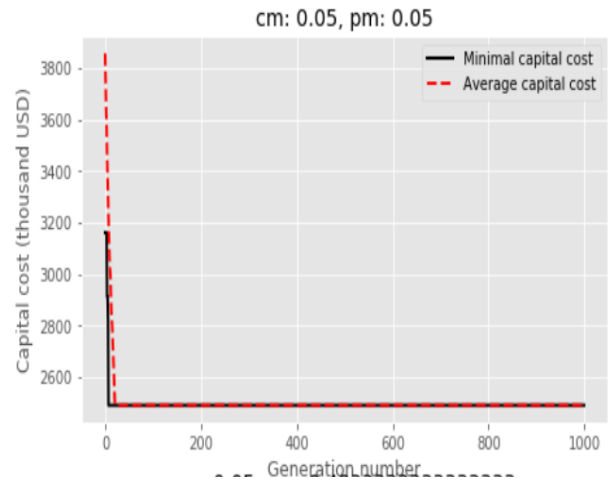

Figure 7: Capital Cost vs Generation Number based on third condition

V. CONCLUSION

In this paper, we have proposed EA (Evolutionary Algorithm) based approach for achieving the optimized RMS, the main objective is to select the optimal configuration such that it can reduce the cost and provide the flexibility. Our EA approach achieves by selecting the optimal solution and evaluated by considering the test part of ANC-101. Further evaluation is performed by comparing the EA approach with the benchmark set and the existing protocol ESGA, here we have consider the three constraint as the condition, our model achieves the value of 2500, 2080 and 2488 for the three condition respectively. Moreover, these values are marginally less than the benchmark set and the existing protocol ESGA. Further analysis can be observed through the respective graph of above condition observed. Hence we conclude by the remark that EA based RMS can be considered for the further research of optimization of research, in future we would be considering the other machine part and some more case study can be expected including some more constraint.

REFERENCES

1. R.G. Landers, "A New Paradigm in Machine Tools: Reconfigurable Machine Tools," Japan-USA Symposium on Flexible Automation, Ann Arbor, Michigan, July 23-26, 2000.
2. J. L. Chirm, D. C. McFarlane, "A Holonic Component-Based Approach to Reconfigurable Manufacturing Control Architecture," Proc. of HolonMas00, London, 2000
3. Renzi, C., Leali, F., Cavazzuti, M. et al. A review on artificial intelligence applications to the optimal design of dedicated and reconfigurable manufacturing systems. *Int J Adv Manuf Technol* 72, 403–418 (2014)
4. P. H. Algoet, "Flow balance equations for the steady-state distribution of a flexible manufacturing system," in *IEEE Transactions on Automatic Control*, vol. 34, no. 8, pp. 917-921, Aug. 1989.
5. Farid, A.M. Measures of reconfigurability and its key characteristics in intelligent manufacturing systems. *J Intell Manuf* 28, 353–369 (2017)
6. Aiping L, Nan X. A robust scheduling for reconfigurable manufacturing system using petri nets and genetic algorithm. Proceedings of the world congress on intelligent control and automation (IEEE) 2006;2:7302–6.
7. Yu JM Doh HH, Kim JS, Kwon YJ, Lee DH, Nam SH. Input sequencing and scheduling for a reconfigurable manufacturing system with a limited number of fixtures. *Int J Adv Manuf Technol* 2013;67(1–4):157–69.

8. Azab A, Naderi B. Modelling the problem of production scheduling for reconfigurable manufacturing systems. *Procedia CIRP* 2015;33:76–80.
9. Galan R. Hybrid heuristic approaches for scheduling in reconfigurable manufacturing systems. *Metaheuristics for scheduling in industrial and manufacturing applications*. 2008. p. 211–53.
10. Dou J, Li J, Su C. Bi-objective optimization of integrating configuration generation and scheduling for reconfigurable flow lines using NSGA-II. *Int J Adv Manuf Technol* 2016;86(5-8):1945–62.
11. Bensmaine A, Dahane M, Benyoucef L. A new heuristic for integrated process planning and scheduling in reconfigurable manufacturing systems. *Int J Prod Res* 2014;52(12):3583–94.
12. Prasad D, Jayswal SC. Reconfigurability consideration and scheduling of products in a manufacturing industry. *Int J Prod Res* 2017:1–20.
13. Abdi, M.A., Labib, A.W.: A design strategy for reconfigurable manufacturing systems (RMSs) using analytical hierarchical process (AHP): a case study. *Int. J. Prod. Res.* 41(10), 2273–2299 (2003)
14. Holttta, K., Suh, E.S., De Weck, O.L.: Trade-off between modularity and performance for engineered systems and products. In: *Proceedings of the 15th International Conference on Engineering Design*, Melbourne, Australia, 15–18 Aug 2005
15. Clark, G.E., Paasch, R.K.: Diagnostic modeling and diagnosability evaluation of mechanical systems. *J. Mech. Des.* 118(3), 425–431 (1996).
16. Koren, Y., Maler-Sperdelozzi, V., Hu, S.J.: Convertibility measures for manufacturing systems. *CIRP Ann. Manuf. Technol.* 52(1), 367–370 (2003)
17. Sun, X., Chu, X., Su, Y., & Tang, C. (2010). A new directed graph approach for automated setup planning in CAPP. *International Journal of Production Research*, 48(22), 6583–6612.

AUTHORS PROFILE



Mr. G. Suresh Babu, had done his B.Tech in 'Mechanical Engineering' and M.Tech in 'Advanced Manufacturing Systems'. At present he is 'Research scholar' at VTU RRC, Muddenahalli, Belagavi. He is carrying his research work on 'Reconfigurable Manufacturing Systems'. He published couple of international journals on Production and Multidisciplinary areas. He had the wide experience in industry and teaching of 10 years together. He holds the 'MIE' membership with Institution of Engineers IEI-India.



Dr. N. Chikkanna, completed his Ph.D from Bangalore University, Bangalore. He did his M.E & B.E at U.V.C.E. Bangalore University & SIT, Tumkur respectively. He has vast experience of 23 years in teaching field at all levels from assistant professor to principal. Presently he is working as Professor and Chairman, Department of Aerospace Propulsion Technology, VTU Center for PG Studies, Bangalore. He received a certificate of contribution from 'Director of Technical Education', 'Govt. of Karnataka. He was the Chairman of Institution of Engineers (India), Karnataka State Centre' from 2016-2018. He Received VGST KFIST –L2 grant of Rs 20 Lakhs for "Establishing the Facility for Air Intake duct design using analysis Tools" during 2014-15. He Published 20 National and International Journals and presented over 18 National & International Conferences.