

Anti-Windup PI Controller with Tracking for BLDC Motor Drive System: Modeling, Simulation and Implementation on Lab View Based FPGA

B. Gunapriya, M. Karthik, I. Abinaya, R. R. Rubia Gandhi, H. Vidhya

Abstract: Most of the Brushless DC (BLDC) motors drives take up proportional integral (PI) controller and pulse width modulation (PWM) scheme for speed control. BLDC motor drive has strong saturation characteristics and saturation results in a windup phenomenon. This paper presents an Anti-windup drive for BLDC motor. An Anti-windup controller (AWC) with tracking has been employed and which has been modeled in MATLAB / Simulink and comparison has been done between conventional PI controller and AWC with tracking at different starting loads. In this paper, dynamic characteristics of the BLDC motor drive have been examined and results are validated with FPGA (Field Programmable Gate Array) based experimental set up.

Keywords: BLDC, Anti-windup, PI, FPGA

I. INTRODUCTION

The BLDC motor speed control has an important role in modern motor control. It has a trapezoidal back EMF, and rectangular stator currents which are needed to generate a constant electric torque [1,2]. Still, ideal rectangular current pattern cannot be taken in to practice due to the phase inductance and finite inverter voltage. To sustain the actual currents flowing into the motor as close to the rectangular reference values the hysteresis or PWM current controllers must be used [3]. The dual closed-loop speed control is found common where outer loop is for speed and inner loop is for current or torque control [4]. This paper focus on the issue of windup phenomenon and various types AW techniques are studied to overcome the same. It also deals with the performance assessment of AWPI with tracking controller and conventional PI controller. Modeling of AWPI with tracking is done by using Matlab/Simulink, and comparison is made with a conventional PI controller at different set speeds and at various loads. The dynamic conditions of the BLDC motor drive have been simulated [5, 6]. The validity and superiority of AWPI with tracking controller confirmed by experimental results that it has improved anti-disturbance ability, less overshoot and less settling time, and improved speed response with wide operating conditions. Tuning the controller is necessary to get the optimum process response [7-9].

Revised Manuscript Received on January 10, 2020.

Dr. B. Gunapriya, Department of EEE, New Horizon College of Engineering, Bengaluru, Karnataka, India. E-mail: gunapriya78@yahoo.in

M. Karthik, Department of EEE, Sri Ramakrishna Engineering College, Coimbatore, India. E-mail: kartik.m1992@gmail.com

I. Abinaya, Department of EEE, Sri Ramakrishna Engineering College, Coimbatore, India. E-mail: abinaya.i@srec.ac.in

R. R. Rubia Gandhi, Department of EEE, Sri Ramakrishna Engineering College, Coimbatore, India. E-mail: rubiagandhi.rajagopalan@srec.ac.in

H. Vidhya, Department of EEE, Sri Krishna College of Engineering & Technology, Coimbatore, India. E-mail: vidhya.karthik@srec.ac.in

There are several methods available for tuning the controller parameters. Here, to adjust the system to desired response, parameters of controllers must be changed by manual tuning methods like Ziegler-Nichols method for maintaining the closed-loop system. In this paper, integral windup problem and anti-windup techniques to overcome the problem of integral windup have been illustrated [10].

II. CONVENTIONAL PI CONTROLLER

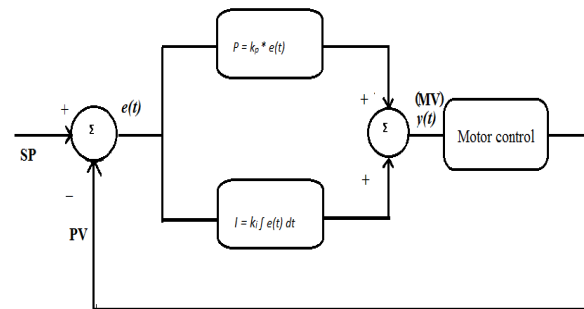

Fig.1. Basic block of PI controller.

The basic block of PI controller (Proportional Integral controller) is shown in Fig1. The PI controller calculates an error value as the difference between a measured process variable (PV) and the desired set point (SP). Tuning k_p and k_i of a control system is the adjustment of its control parameters like overshoot, settling time to the optimum values for the desired control response [11].

III. BACKGROUND STUDY OF ANTI -WINDUP CONTROLLER

Mostly controllers of variable speed drives employ PI controllers. The control circuit of these drives has inner current control loop and outer speed control loop. The inner current control loop provides fast dynamic response and peak current protection. The outer speed control loop generates the speed command for current controller [12]. In these controllers, the current or speed command is limited to a maximum value which causes the integral state to be inconsistent and become very large, causing integral windup phenomenon. Many anti-windup techniques are available to overcome the effect of the integral windup problem. The author studied the effects of integral windup phenomenon and found that in variable speed drives, they cause large overshoot, slow settling time and instability in the speed response. The author proposed the conditional integration anti-windup technique.

Anti-Windup PI Controller with Tracking for BLDC Motor Drive System: Modeling, Simulation and Implementation on Lab View Based FPGA

In this method, the integral action is suspended, and only the proportional action is activated, when the control input is saturated. The author proposed the limited integrator scheme, in which the integrator value is limited by the feedback control signal with a high gain dead zone during which system generates zero output when the input is within a definite region [13].

The author suggested the tracking based anti-windup scheme for variable speed motor drives [12]. This control scheme utilizes the difference between the saturated and the unsaturated control input signals to generate the feedback signal to tackle the integrator input. In these schemes, the overshoot depends on the feedback gain of the control system rather than the PI gain [13]. The author compared and evaluated the AW techniques and proposed a novel method of anti-windup technique with integral state prediction. The author proposed a new anti-windup PID controller to improve the performance of variable speed drives and physically realized the same for the speed control of a vector-controlled induction motor drive fed by a pulse width modulated voltage source inverter.

In this paper, the integral windup problem and the anti-windup techniques to overcome the problem of integral windup have been illustrated. Dynamic parameters of the BLDC motor drive have been inspected, and results are analyzed. Experimental validation for the simulated results is also done. The saturation of the output produced by the system controller causes the integral windup problem. It leads to an overshoot in the output of the PI controller which creates an oscillation in the motor speed. Previous investigators and evolution of control systems have made a great contribution to the BLDC motor drives, but the comprehensive technique is not available for Anti-windup PI (AWPI) controlled BLDC motor drives.

IV. ILLUSTRATION OF ANTI-WINDUP CONTROLLER WITH TRACKING

Integral windup is a condition which occurs in PI controllers when a large integral error is present in the system. When a large step disturbance is encountered in the system, integral terms accumulate a significant error during the rise time, thus causes overshoot. The integrator continuously builds up its value during this integral error condition though the output is saturated. The integrator then unwinds when the servo system reaches its destination causing excessive oscillation [14, 15].

There are some limitations due to the windup phenomenon in actuators like limited motor speed and discontinuous operation. When the control system is operating over a wide range of conditions, the control variable can reach the actuator limits. Then feedback loop does not work further, and the system begins to run in open loop condition since the actuator will stay at its limit independently of the process output if the actuator remains saturated. The integral phenomenon will continue to build up, and then the error is certainly zero. The integral term and the controller output may become very large. The control signal will saturate even when the error changes and it may remain for a long duration until the integrator, and the controller output comes inside the saturation range, consequently large transients will occur. This is stated as

integral windup. In BLDC motor drive, integral windup causes overshoot in PI controller speed performance [16]. Integral windup can be limited by either limiting the controller output or by using external reset feedback. External reset feedback is named as anti-windup technique in PI controller which controls the integral windup and reduces overshoot.

V. SIMULATION OF BLDC MOTOR DRIVE WITH PI CONTROLLER

In the BLDC motor drive, the PI controller is used in the speed control loop. Speed error is given as input to the PI controller. It determines the reference value of voltage V_{ref} to control the drive parameters. The controller gain in the PI controller is set as $k_p=1$, $k_i=5$ using Ziegler-Nichols method of PI tuning. A simulation model of the BLDC motor drive using PI controller is shown in Fig 2. Dynamic response of the drive is analyzed, and it depends upon the reference voltage produced by the speed loop in PI controller of the drive system. The voltage reference from speed loop decides the PWM signal of a three-phase inverter. Since the motor fed by an inverter, output voltage of the inverter decides the speed of the motor. The performance of the drive is analyzed with various set speeds and various load conditions.

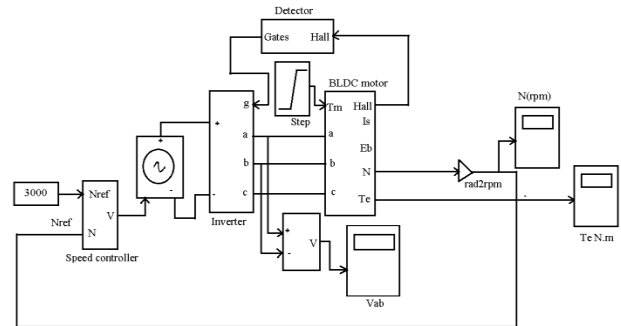

Fig.2. Simulation model of BLDC motor drive using PI controller

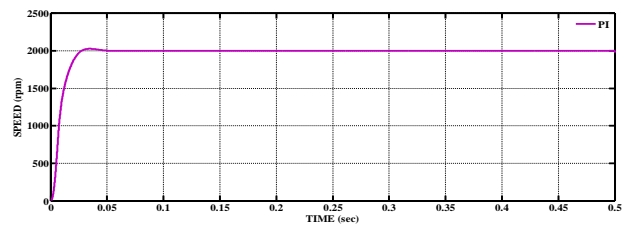

Fig.3. Speed of BLDC motor drive at no load using PI controller

Speed characteristics of BLDC motor drive at a reference speed of 2000 RPM is shown in Fig 3. During this analysis, the motor runs at no load. From Figure 6, peak overshoot is high with a change in speed. At starting the motor gets oscillated due to change in speed of 2000 RPM. It runs at set speed till the load is varied. The PI controller based drive gets oscillation when starting torque is high. It is the effect of poor control due to overshoot in the reference voltage produced by PI controller.



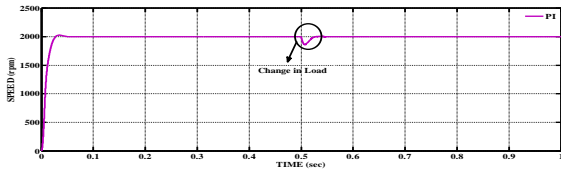

Fig.4. Speed response of BLDC motor drive at load of 1.2 Nm using PI controller

From Fig 4, it is evident that the restoration time has reduced. The speed drop is also high when there is a change in load. The time taken to settle back to its reference speed after speed drop is stated as restoration time. The speed performance of drive at a reference speed of 2000 RPM and with the load of 1.2 Nm is shown. For variable load analysis, the load is increased from no load to 1.2 Nm at 0.5 sec and then torque settles at steady state condition at 0.54sec.

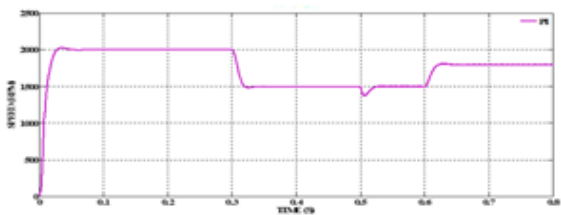

Fig.5. Speed response of BLDC motor drive using PI controller at various speed references

Speed response of BLDC motor drives using PI controller at various speed references is shown in Fig 5. When the reference speed varies from 2000 RPM to 1500 RPM at $t = 0.3$ sec, speed error increases, the PI controller produces increased voltage as a reference voltage to attain the set speed. The motor settles at the set speed with overshoot. After that, it runs at the set speed till the load is varied. At $t = 0.5$ sec, the load of 1.2 Nm is suddenly increased causes voltage drop and speed drop. Drop in speed again increases speed error, and it is compensated by PI controller by raising reference voltage. It shows that the machine follows the reference speed and produces minimum speed error. The perfect rise in voltage increases the speed and attains the set speed after the restoration time. The performance of BLDC motor drive using PI controller with various set speeds of 1000 RPM, 2000 RPM and 3000 RPM and at 100% load is shown in Table I.

VI. SIMULATION OF THE BLDC MOTOR DRIVE WITH ANTI-WINDUP PI CONTROLLER WITH TRACKING

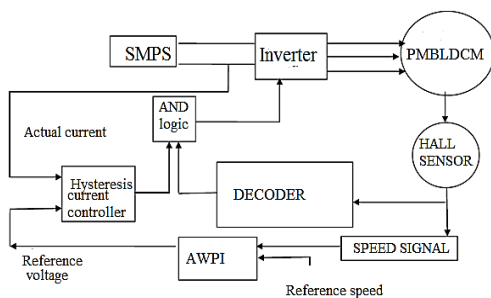

Fig.6. Block diagram of AWPI controller with tracking

The basic blocks of the BLDC motor drive are depicted in Fig6. The drive comprises of an AWPI with tracking speed controller, switched-mode power supply (SMPS), hysteresis controller, Hall sensor, BLDC motor and voltage source inverter (VSI). The voltage reference signal is resulting from the speed error signal, which denotes the difference between the desired speed and the actual speed. The speed of the motor is sensed by Hall sensor is compared with its speed reference value and the error is given to the AWPI controller with tracking for corrective actions. The output of the controller is measured as the reference torque by a hysteresis current controller loop [20].The reference current is produced from the reference torque, as current is directly proportional to the torque. The reference current is compared with actual current from the BLDC motor drive system. The output of the hysteresis controller is sent to the AND logic where switching commands are created to drive the inverter switches[17-19].The hysteresis current controller is responsible for generating the switching signals for the MOSFETs of voltage source inverter supplied with SMPS. The Hall sensor switches give digital pulses that can be decoded into the desired three-phase switching sequence. The sensed speed signal is given as input to the AWPI with tracking controller. It produces a reference voltage V_{ref} . The controller gain is set as $k_p = 1$, $k_i = 5$ using Ziegler–Nichols method of tuning. Using these gain values, controller is tuned, and thus the speed is controlled by AWPI with tracking controller. To analyze the dynamic response of the drive, the load is suddenly changed during run time. Here, the steady state response and dynamic response of the drive with AWPI with tracking controller is analyzed. Using Matlab/Simulink software, the drive system is modeled, simulated and analyzed.

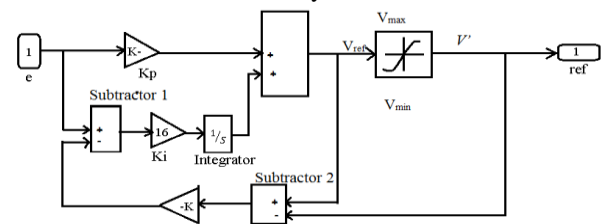

Fig.7. Simulation model of AWPI controller with tracking controller

A simulation model of AWPI with tracking controller is shown in Fig 7. In Fig 7, the speed error e processed by AWPI tracking controller to produce voltage reference V_{ref} . The reference voltage V_{ref} decides the speed of the BLDC motor. Whenever the voltage of the controller exceeds the maximum value of reference voltage, it produces overshoot in a motor speed. This is the effect of the integral windup phenomenon. When V is greater than V_{max} , the controller voltage gets saturated by saturation block. In subtraction block 2, the difference between the saturated and unsaturated value of controller voltage is calculated. This error in voltage is multiplied by the value K_{lim} to limit the integrator input. This calculated data is

Anti-Windup PI Controller with Tracking for BLDC Motor Drive System: Modeling, Simulation and Implementation on Lab View Based FPGA

Table-I. The performance of BLDC motor drive using PI controller with various speeds and at 100 % load

Speed (RPM)	Peak Overshoot (%)	Steady state error (%)	Rise time (sec.)	Peak time (sec.)	Settling time (sec.)	Speed drop during load change (%)	Restoration time (sec.)
1000	0.04	0.027	0.0177	0.0414	0.05	11.9	0.03
2000	1.4	0.015	0.0213	0.035	0.1	6.9	0.06
3000	3.33	0.01	0.226	0.035	0.115	5.3	0.08

Saturated by speed error in subtraction block 1 which is fed to the integrator. It limits the integral action on controller voltage. Thus, it controls the speed. In this analysis, Klim is kept high to settle down the speed quickly. The performance of the drive is investigated with different reference speeds and at various load conditions.

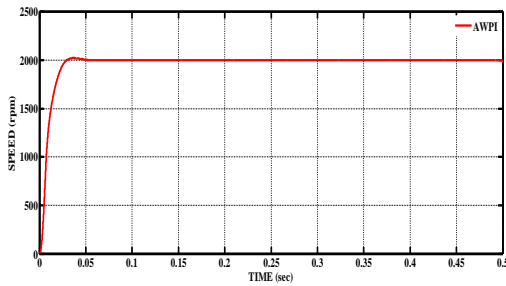

Fig.8. Speed of BLDC motor drive at no load using AWPI controller with tracking

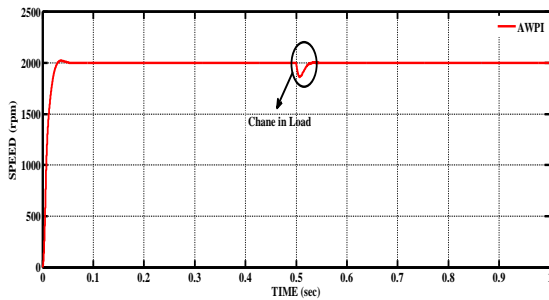

Fig.9. Speed of BLDC motor drive at variable load using AWPI controller with tracking

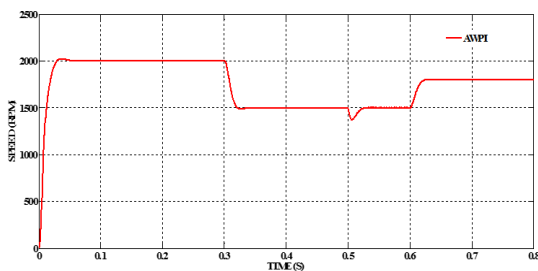

Fig.10. Speed response of BLDC motor drive using AWPI with tracking controller at various speed references

Speed characteristics of BLDC motor drive at a reference speed of 2000 RPM and the motor runs at no load is shown in Fig 8. It is observed that the speed controller output is smooth, with less number of spikes of low magnitude and

There is no oscillations, overshoots or dips in the motor speed. The settling time is 0.026 sec.

The speed performance of drive at 2000 RPM reference and the 1.2 Nm load is shown in Fig 9. For variable load analysis using AWPI with tracking, the load of 1.2 Nm on the machine is increased at the time of 0.5 sec. It is observed that the rise time of the motor is about 0.02 seconds. AWPI controller with tracking reduces overshoot in the reference voltage so that the overshoot in speed and torque ripple is minimized compared to PI controller.

Speed response of BLDC motor drive using the AWPI controller with tracking at various speed references is shown in Fig10. When the reference speed varies at $t = 0.3$ sec, speed error increases, the AWPI controller with tracking produces increased voltage as a reference voltage to attain set speed. The motor settles at the set speed with less overshoot. With the anti-windup action, the motor follows the reference speed and produces minimum speed error. The performance of BLDC motor drive using AWPI with tracking controller is shown in Table II.

The performance characteristics of the AWPI controller with tracking validate its control on BLDC motor drive. To analyze the parameters of speed drop during a change in load and restoration time, a load of 1.2 Nm is increased at the time of 0.5sec. Peak overshoot in percentage value lies in the range of 0.015 to 0.76. Peak time has a variation of 0.065 sec to 0.12. Rise time has a variation of 0.0192 sec to 0.025 sec. Settling time has a variation of 0.05 sec to 0.12 sec. Steady state error in percentage value lies in the range of 0.025 to 0.013. Speed drop during load change in percentage value lies in the range of 11.9 to 7.2. Restoration time lies in the range of 0.035 sec to 0.04 sec. During mid-value of steady state occurs and restoration time is 0.06 sec.

VII. EXPERIMENTAL VALIDATION

Effectiveness of the proposed controller performance is analyzed using experiments to verify the results of the simulation. A BLDC motor of rating 400W, 3 phase, 30V, 3000 RPM is experimenting using the Spartan 3 FPGA. It is a 144 Pin, Enhanced serial (SPI) and parallel flash memories, and efficiently integrating the functions of many chips into a single FPGA[16-19]. AWPI Controller algorithm is programmed with in the FPGA. It is to build the sense hall effect sensor signal and produces triggering

Table-II. The performance of BLDC motor drive using AWPI with tracking controller with various set speed and at 100% load

Speed (RPM)	Peak Overshoot (%)	Steady state error (%)	Rise time (sec.)	Peak time (sec.)	Settling time (sec.)	Speed drop during load change (%)	Restoration time (sec.)
1000	0.015	0.025	0.0192	0.065	0.05	11.9	0.035
2000	1.1	0.015	0.0226	0.0368	0.08	6.9	0.06
3000	0.76	0.013	0.025	0.042	0.12	7.2	0.04

Table-III. Performance comparison of simulation and experimental results

Set Speed	Peak overshoot %		Steady state error %		Speed drop during load %		Settling time after load Change in Sec	
	SIM	EX	SIM	EX	SIM	EX	SIM	EX
	1500	0.2	0.3	0.02	0.1	8.53	10	0.03
2000	0.8	1	0.015	0.09	7	9	0.03	0.1
2500	1.6	1.8	0.012	0.07	6	7.5	0.03	0.12

Pulses for the inverter. It controls the voltage as per AWPI program. The hex bridge inverter is designed with six MOSFETs. MOSFET receives triggering signal through a driver chip. Driver chip provides virtual ground for MOSFETs. An optical isolator is introduced between the low voltage FPGA and High voltage driver chip. It protects FPGA from high voltage as well as from any faults in the drive. The speed of the machine is sensed using an inductive proximity sensor. On a computer, customized program is developed using LAB VIEW (laboratory based virtual instrumentation engineering work bench). Instead of DAQ card, VISA (Virtual Instrument Software Architecture) tool of LAB VIEW software is used in this paper. It minimizes the cost of hardware system [16-20]. Experimental setup of the drive is shown in Fig 11. It provides the benefits of Reduced time of detection, prototype and to market. It has protection of intellectual property using embedded, Field-Programmable Gate Array (FPGA) based technology. The LABVIEW program has two screens, front screen and block diagram. The front screen consists of inputs and outputs. Block diagram consists of control circuit. LAB VIEW receives the signal from FPGA; to control this serial enable push button is used in LAB VIEW front screen. The data are received as a string with sampling time. In LAB VIEW, VISA tool is opened to receive data and it converts string type data to a number. It is displayed in scope, from this speed parameter like overshoot, Steady state error, Speed drop during load and settling time after load Change are noted. FPGA is programmed using VHDL (Very high speed Hardware Description Language). Hence, it is easy to implement in VHDL.

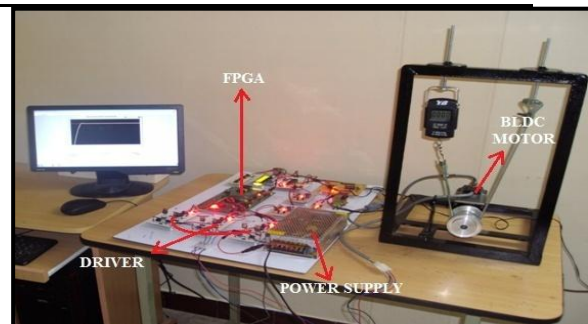

Fig.11. Experimental Setup of the Drive

Performance comparison of AWPI controller with tracking based BLDC motor drive in simulation and experiments is shown in Table III. It shows the comparison of simulated and experimental result at various set speeds. Number of samples per second is high when the processing time is low it results better accuracy. Hence the experimental results of the AWPI based BLDC drive using FPGA are almost equal to the simulation results [21-31].

VIII. COMPARATIVE RESULTS AND DISCUSSION

When the reference speed varies at $t = 0.4$ sec, speed error increases, the AWPI controller with tracking creates reference voltage to attain the set speed. The motor settles at the set speed with less overshoot compared to PI controller. After that, it runs at the set speed till the load is varied. At $t = 0.5$ sec load of 1.2 Nm is suddenly increased causes voltage drop and speed drop.

Anti-Windup PI Controller with Tracking for BLDC Motor Drive System: Modeling, Simulation and Implementation on Lab View Based FPGA

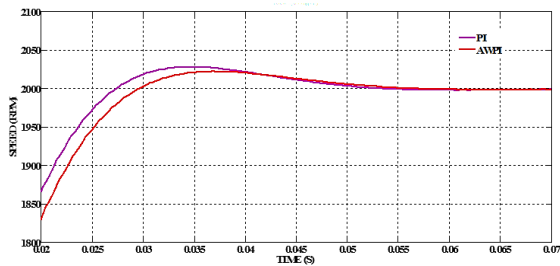

Fig.12. Overshoot comparison of PI controller and AWPI controller with tracking based BLDC motor drive

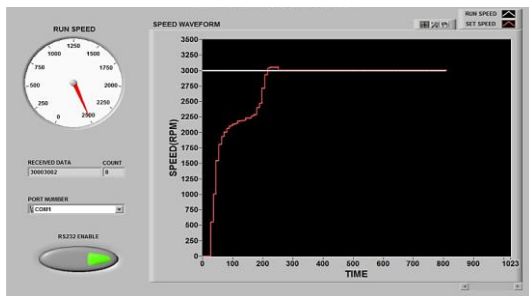

Fig.13. Speed performance of AWPI controller at 2500 RPM

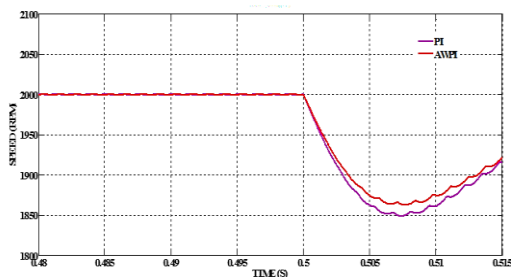

Fig.14. Speed drop during load change comparison of PI controller and AWPI controller with tracking

The perfect rise in voltage increases the speed and attains the set speed after the restoration time. From Fig12 and Fig13, it is evident that the performance obtained using AWPI controller with tracking is better than those obtained using PI controllers. The peak overshoot and settling time after load change in the proposed controller is reduced better than in the PI controller. Mean time the steady state error is low in AWPI controller with tracking based drive. Speed drop during load change is highly reduced compared to the PI controllers. Because of the high value of K_{lim} , this peak overshoot of the motor is reduced by 16 % compared to PI controller. AWPI controller with tracking reduces steady state error by 50 % compared to PI controller. Rise time, peak time and settling time are very less compared to the conventional PI controller. Drop in speed during a change in load and restoration time of the motor are also reduced effectively.

Speed performance of AWPI at 2500 RPM is shown in Fig 13. In this speed, motor has peak overshoot of 2% which is lesser than simulation result. Motor performance improves in the aspect of steady state error and speed drop during load change when speed increases. The deviation of the transient response from the set reference following variation in load torque is found to be negligibly small along with a desirable reduction in settling time for the AWPI. The responses of speed are smooth and very less oscillation in the case of

AWPI. This is due to robust and accurate control structure of the AWPI. The results show significant improvement in the response of BLDC motor with the AWPI.

IX. CONCLUSION

The paper presented a performance comparison between an Anti-windup PI controller with tracking and the conventional PI controller. With the simulation, the speed control of BLDC motor drive with PI controller and AWPI controller with tracking is achieved. Using Mat lab/Simulink the detailed simulation model has been developed. The BLDC motor drive employed here with the PI control technique and the PWM scheme has saturation features that result in the windup phenomenon. Due to Integral windup, PI controller linked with the major problems of overshoot and settling time. For rectifying this problem, an AWPI controller with tracking has been used and discussed in detail. To avoid integral wind up, saturation with high gain K_{lim} is introduced in the developed Simulink model. A comparative analysis through simulation has been done, and performance parameters are obtained. Speed, torque response graph has been plotted with various set speeds and at various loads. It is observed that the performance of the BLDC motor drive is improved using AWPI controller with tracking. It has the better anti-disturbance ability, less overshoot and less settling time and improves the speed response ability than PI controllers. Simulation results authenticate the validity and superiority of the Anti-windup PI controller with tracking for implementing on hardware. The results provide evidence that the Anti-windup PI controller has better anti disturbance ability, less overshoot and less settling time of the system, and can advance the speed response ability. The experimental set up is done by using FPGA and experimental results are verified by comparing the simulation result.

REFERENCES

1. Pillay, P & Krishnan, R.(1988). Modeling of permanent magnet motor drives.IEEE Transactions on Industrial Electronics, 35(4), 537-541.
2. Rashid, MH. (2010). Power electronics handbook: devices, circuits and applications. Academic press.
3. Krishnan, R. (2010). Permanent magnet synchronous and brushless DC motor drives, Taylor and Francis Group, CRC Press.
4. Bose, BK. (1997). High performance control and estimation in AC drives, In Proceedings of 23rd International Conference on Industrial Electronics, Control and Instrumentation, IECON 97, 2, 377-385.
5. Dave Wilson.(2012). Introduction to InstaSPIN™-BLDC Motor Control Solution, Texas instruments.
6. Abu-Rub, Haitham, Atif Iqbal, &JaroslawGuzinski. (2012). High performance control of AC drives with MATLAB/Simulink models, John Wiley & Sons.
7. Loughton, MA & Say, MG. (2013). Electrical engineer's reference book, Elsevier.
8. Johnson, GW. (1997). LabVIEW graphical programming, Tata McGraw-Hill Education.
9. Kurien, M, Prayagkar, A &Rajeshirke, V. (2014). Overview of Different Approaches of PID Controller Tuning, International Journal of Research in Advent Technology, 2(1), 167-175.
10. Li, Xi, Park, JG & Shin, HB. (2011). Comparison and evaluation of anti-windup PI controllers, Journal of Power Electronics, 11(1), 45-50.

11. Park, JG, Chung, JH & Shin, HB. (2002). Anti-windup integral-proportional controller for variable-speed motor drives, Journal of Power Electronics, 2(2), 130-138.
12. Peng, Y, Vrancic, D & Hanus, R. (1996). Anti-windup, bumpless, and conditioned transfer techniques for PID controllers, IEEE Control Systems, 16(4), 48-57.
13. Shin, HB. (1998). New anti-windup PI controller for variable-speed motor drives, IEEE Transactions on Industrial Electronics, 45(3), 445-450.
14. Singh, B & Singh, S. (2009). State of the art on permanent magnet brushless DC motor drives, Journal of Power Electronics, 9(1), 1-17.
15. Tariq, M, Bhattacharya, T, Varshney, N & Rajapan, D. (2016). Fast response Anti-windup PI speed controller of Brushless DC motor drive: Modeling, simulation and implementation on DSP, Journal of Electrical Systems and Information Technology, 3(1), 1-13.
16. Benrejeb, W & Boubaker, O. (2012). FPGA modeling and real-time embedded control design via LabVIEW Software: Application for swinging-Up a pendulum, International Journal on smart sensing and intelligent systems, 5(3), 576-591.
17. Bishop, RH. (2007). LabVIEW 8, Upper Saddle River, NJ :Pearson.
18. Bitter, R, Mohiuddin, T & Nawrocki, M. (2006). LabVIEW: Advanced programming techniques, CRC Press.
19. Chu, Pong P. (2011). FPGA prototyping by VHDL examples: Xilinx Spartan-3 version, John Wiley & Sons.
20. Gunapriya.B, Sabrigiriraj.M, Karthik.M, NithyaDevi.R. (2016). Survey on Speed Controllers for a Permanent Magnet Brushless DC Motor, ARPN, 11(2).
21. GunaPriya B., Sabrigiriraj M., (2017), "Real-Time Implementation and Performance Evaluation of Brain Emotional Learning Developed for FPGA-based PMLDC Motor Drives", Journal of Testing and Evaluation, Vol. 45, No. 3, pp. 987-1004
22. GunaPriya B., Sabrigiriraj M., Pavithra C.V., Vivekanandan C.(2015), "Performance Enhancement of BLDC drives in Electric Vehicles by using Fuzzy Gain scheduling PI Controller", International Journal of Applied Engineering Research, Vol.10, No.2, pp.3993-4006
23. GunaPriya B., Sabrigiriraj M. (2016), "Review: Belbic in Control Engineering", International Engineering Research Journal, Vol.2, No.3, pp.1254-1261.
24. GunaPriya B., Sabrigiriraj M., Karthik M., Deepa B. (2015), "Modelling and Analysis of Adaptive Neuro Fuzzy Inference System based BLDC Motor under different Operating Conditions", International Journal of Applied Engineering Research, Vol.10, No.88, pp.57-62.
25. GunaPriya B., Speed Control of Three Phase Switched Reluctance Motor Using Particle Swarm Optimization IEEE explore, pp. 315-319, 2012.
26. GunaPriya B., Sabrigiriraj M., Karthik M., Role of BLDC motor drives in vehicular applications, Advances in Natural and Applied Sciences, vol.11, no. 6, 2017.
27. GunaPriya B., Sabrigiriraj M., Karthik M., Simulation Study of IBELBIC Based BLDC drives for electric vehicles, Journal of Engineering Technological Research, vol. 8, ISSN: 2229-9262, 2017.
28. GunaPriya B., Sabrigiriraj M., Karthik M., Power Electronic Drives and Control Technology Status: Brief Review, Advances in Intelligent Systems and Computing (AISC), book series, Springer Singapore, vol. 467, pp. 493-512, 2017.
29. GunaPriya B., Sabrigiriraj M., Karthik M., Simulation of BELBIC in BLDC motor drive system for electric vehicle, International Journal of Electrical and Electronics Engineering (SSRG-IJEEE) ISSN: 2348-8379, vol.4, no.2, pp.1-5, 2017.
30. GunaPriya B., Sabrigiriraj M., Karthik M., Theory evaluation of PI, AWPI, fuzzy PI for adjustable speed BLDC motor drives, journal of advanced research in dynamical and control system, special issue on allied electrical and control systems-2/2017, vol.9, pp.245-261.
31. Gunapriya, B & Sabrigiriraj, M 2016, 'Role of Microprocessors, Digital ICs In Electric Drive Control and Significance of FPGA – Review', Asian Journal Of Research In Social Sciences and Humanities ISSN:2249-7315. (Annexure I) Updated List 2016

AUTHORS PROFILE



B. Gunapriya, received her doctoral degree in the field of Digital control of electrical drives under Anna University Chennai. Presently, she is working as an Associate Professor in the department of Electrical and Electronics engineering at New Horizon College of Engineering, Bangalore. Her interests are in Power electronics and intelligent drives.



M. Karthik, obtained his B.E degree in Electrical and Electronics Engineering from Vel Tech Multi Tech Dr. RR & Dr. SR Engineering College, Chennai, Tamilnadu, India in the year 2013. He obtained his M.E Degree in High Voltage Engineering from National Engineering College, Kovilpatti, Tamilnadu, India in the year 2015. He is pursuing Ph.D (Part Time) under Anna University, Chennai. His interest includes high voltage insulation engineering



Ms. I. Abinaya, is an Assistant Professor in the Department of Electrical and Electronics Engineering. She did her Post Graduate degree in Embedded systems from SASTRA University, Thanjavur and her Under Graduate degree in Electrical and Electronics Engineering from Panimalar engineering college, Chennai. She had been a University Rank holder and was given a gold medal. He has a teaching experience of two years. Her area of interests is embedded system and IoT.



R. R. Rubia Gandhi, is an Assistant Professor in the department of Electrical and Electronics Engineering of Sri Ramakrishna Engineering College. She has two years of industrial experience. She received her B.E., Electrical & Electronics Engineering from Karpagam College of Engineering, Coimbatore, India in 2011. She received her M.E., Power Electronics and Drives from Sri Krishna College of Engineering & Technology, Coimbatore, India in 2015. She has attended two national conferences and two international conferences. She has published one paper in an international journal. Her field of interest is Power electronics.



H. Vidhya, is the Assistant Professor in the department of Electrical and Electronics Engineering of Sri Ramakrishna Engineering College. She received her B.E., Electrical & Electronics Engineering from Erode Sengunthar Engineering College, Erode, India in 2010. She received her M.E., Power Electronics and Drives from Sri Ramakrishna Engineering College, Coimbatore, India in 2016. She has attended one international conference. She has published one paper in international Conference. Her field of interest is Power electronics and Special Electrical Machines.