

# Smart Controller for Efficient Domestic Cashew nut Cutting Machine

Rubala R., Benisha M., Anisha M., Thandiah Prabu R.

**Abstract:** India is one of the world's largest country in terms of exporters of cashews nuts in kernel form. Currently, more number of labours are engaged in the cashew processing industry. This research work, an automotive cashew shelling method is introduced to improve the production efficiency. It is an electronic based system which enables a continuous flow of shelled. After de-shelling the cashew nut, it falls beneath the cutter due to gravitational force and shelled cashew nuts cumulated in a vessel. Thus the proposed system has the advantage of reducing man power, time consuming and also increases the selling cost. It comprises two process. They are heating and punching process. Both processes are used to remove the cashew kernel from the shell without damage. Here a servo motor is used to extract the shell from the raw cashew. In addition, here PI controller is used to control the entire operation. Then, two blades are used to cleft the nut by operating as handle of cutter. Thus the operation forces the shell to fracture open without detaching the kernel.

**Keywords:** MATLAB/SIMULINK, Automotive cashew shelling machine, PI Controller.

## I. INTRODUCTION

Among the cashew exporting countries India is one of the top producer and second largest cashew consumer in the world. Cashew is the highly valued nut and very important cash crop in the world market [2]. In Indian cashew processing industries exports 1.2 million tonnes of cashew in 3650 mills around the country and 95% women labours working around the country is given by Jadhav. R.A in (2006). The cultivation area of cashew are highest. In real time cashew processing industries in India gives lots of employment and make enter to world marketing trade [2]. Design of automated cashew shelling machine is completely addressed by S.J. Ojolo, et al., in (2009) it will increase the efficiency of cashew nut shelling process and brings down the man power where more number of skilled women are engaged under cashew processing industry for doing different processes such as drying shelling, peeling, grading, packing[16]. The ultimate desire of this research is to bring automated machine for the

**Revised Manuscript Received on January 15, 2020.**

\* Correspondence Author

**Rubala.R\***, Department of Electronics and Communication Engineering, Jeppiaar Institute of Technology, Sriperumbudur, India.

Email: rubalar@jeppiaarinstitute.org

**Benisha.M**, Department of Electronics and Communication Engineering, Jeppiaar Institute of Technology, Sriperumbudur, India.

Email: benishaxavier@gmail.com

**Anisha.M.**, Department of Biomedical Engineering, Kalasalingham Academy of Research and Education, Krishnan koil, India. Email: anisha@alu.ac.in

**Thandiah prabu.R.**, Department of Electronics and Communication Engineering, Jeppiaar Institute of Technology, Sriperumbudur, India.

Email: thandiah@gmail.com

use of people who are in need of it domestically. Development of Automated cashew shelling machine to diminish the manpower and to enhance the quality of the kernel by extract without any crack in the kernel [15].

Traditionally cashew nut processing methods are given by Jim Fitzpatrick in (2011) which involves the open-pan roasting and shelling carried by placing the dried cashew nuts on the flat stone and crack with wooden mallet and batten. In open-pan roasting method, the raw cashew nuts are dried under sun and dunked briefly in water. Then the cashew nuts are heated over the fire in an iron with holes and stirred continuously to prevent over burning.

In Indian cashew nut processing industries involves the various processing steps to produce the whole and tasty cashew kernels and make country to enter in to world market trade [2]. In existing system of cashew processing is addressed by Jim Fitzpatrick in (2011) the raw cashews are extracted from the cashew apple. The shell of the raw cashew is leathery and not brittle. So the cashew are roasted to make the shell condition loosen and brittle to easily remove the nut from the shell [15]. Traditionally, roasting of cashew shell has been done by steam cooking, drum roasting and hot oil method, open roaster method etc. shelling process can be carried out either manually, semi-automotive, fully automotive [5]. But for domestic users the stages of cashew roasting and shelling are unlikely to take place because of high equipment cost. Domestically, open pan method is performed for roasting and extraction of kernels from the cashew shell is done by placing the razz cashew on a flat type stone and fracture with a hammer or mallet, manual hand held cutter, mechanical manual cutter[16]. The various processing steps involved in the cashew processing industries are given by Balasubramanian in (2007), They are,

1. Steam cooking process
2. Cashew shelling process

Steam cooking process also known as the steam roasting process consists of two boilers. One is baby boiler and another is cooking boiler. The raw cleaned cashew nuts are boiled using these boilers until the change of color from grey to brown.

The steam is produced through the baby boiler which is hand stocked having fire tube. Combustion air drawn through top of the boiler.

Cashew nut cooking boiler is a cylindrical boiler where the cashew nuts are feed through the top of the boiler and discharged from the side near bottom of the boiler. The boiler picture is shown in Fig 1.



**Fig.1.Steam Cooking Boiler**

Once the cashew nut is loaded, steam with the pressure of 4.5-5 kg cm-2 is flows into the boiler. After the cashew nuts are boiled, the rest and spare steam starts leaking at the outlet present at the bottom of the boiler.[5]. The complete machine designed using motor. During operation, it cracks cashew nuts by impact given by an impeller and it is driven by electric motor. A revolving pedal sets the shell against soil casting and pierces them on the convex side by means of two blades. The two blades are used to split the nut by operating the handle of the cutter. Thus the operation forces the shell to crack open without rupture the kernel. The cashew shelling machine picture is shown in Fig.2. [9- 12]



**Fig 2. Cashew nut cutting machine**

The Proposed model is used to brings down the man power and to improve the efficiency of cashew nut production for the user who are all need it domestically. The automotive cashew nut cutting machines are small in size and the time required to doing such process are very much reduced.

**II. ROASTING AND SHELLING PROCESS**

In this proposed system, basically consists of two process such as heating and cutting and the concept of automated cashew shelling process is used in small scale units and Domestic purpose. This system will eradicate the performance of manual power to remove the shell from the kernel .PI controller is used to perform both process such as heating and shelling process. After the shelling process the nuts are collected beneath the cutter. In hardware implementation, sensor is used to sense the cashew output. The complete system can be designed and developed by use of hardware and its software but this software model describes

the overall design techniques of domestic cashew processing method. All the cashew processing methods are designed under the guidelines and features of the MATLAB/SIMULINK tools.

**III. SYSTEM ARCHITECTURE**

In the cashew nut cutting process, PI controller is designed to organize and control the heating and cutting process. Roasting drum is used in cashew heating process is like a rotating drum. Cashew nut are initially stored in the cashew feeder. From the cashew feeder cashew nuts are sent to the rotating drum where the cashews are roasted and drum will rotate at certain direction.

Heating element is used to heat the cashew from the feeder and stepper motor is used to rotate the drum at a precise rpm in appropriate direction. The PI controller used to maintains the appropriate value to heat cashew in the rotating drum and also speed and torque function of the stepper motor at particular rpm is maintained by the PI controller.

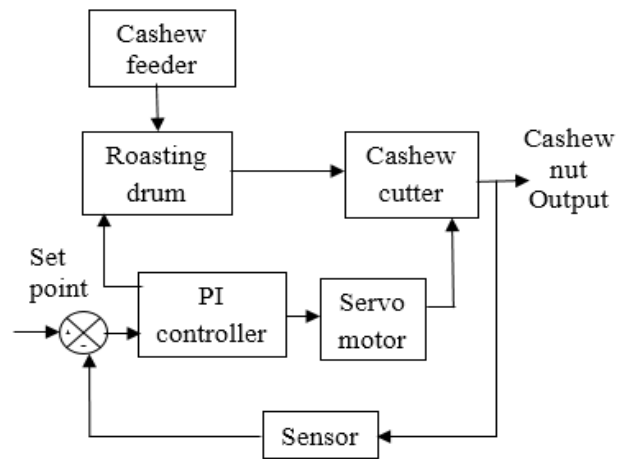

**Fig.3. Proposed Automotive Cashew nut Cutting system**

After the heating process, the roasted cashew shells are to become brittle and loosens the kernel inside the shell. Then some delay time will occur to cool the cashew nut. Servo motor is switched on for doing the cashew cutting process, here the motor is connected with the two blades used to punch the cashew for the removal of cashew kernel from the shell. The proposed automotive cashew nut cutting system shown in Fig 3.

After the cutting process cashew kernels are collected beneath the cutter. The entire operation of the servo motor is controlled by PI controller. IR sensor is used to sense the output. Sensor is placed beneath the cutter to examine whether the cashew kernel is obtained or not.

**A. PI CONTROLLER**

In the cashew processing uses the PI controller to control the entire operation. Manjusha Patil in (2014) illustrates the various PI controller characteristics [14] is the special type of PID controller mainly used in industrial applications and ON-OFF tuning control applications. This fuse the attributes of Proportional and integral controller function.

The error value of the system is amplified by the proportional Controller and this effort of control given to the system is directionally proportional to the error value and integral effort of control is directly proportional to integral function [17]. The conventional structure of the PI controller is shown in Fig.4

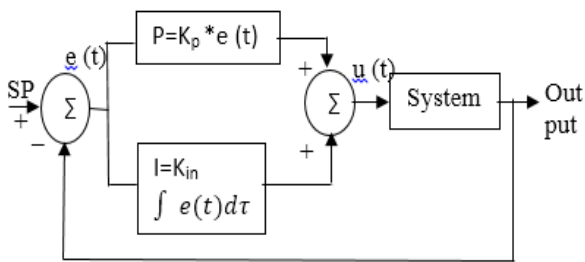

Fig.4.General structure of PI controller

The transfer function model of PI controller is shown below.

$$u(t) = k_c(e + \frac{1}{T_i} \int_0^t e dt + T_d \frac{de}{dt}) \quad (1)$$

The proportional gain function ( $K_p$ ) is given by the equation is  $u_p(t) = k_c e$  (2)

The integral gain function ( $K_i$ ) is given by the equation is  $u_i(t) = \frac{k_c}{T_i} \int_0^t e dt$  (3)

In this research work Proportional controller is used to deploy the steady state error value but causes the large overshoot problem [14]. Gain of the proportional controller will not fully eliminate the steady state error so, try to add an integral control. It takes the temperature value from the heating element and the output is connected to the plants such as drum, stepper motor and servo motor. For the motor functioning the input reference values are convert to electric pulses to rotate the motor shaft.

### B. Roasting process

Before the process of cashew shelling, cashews are made to be brittle and loosen for extract the cashew kernels from the nut shell [22]. In the heating process of cashew the nuts releases the shell liquid and moisture content of the nuts are reduced to make the shell brittle and facilitates the removal of the kernels when crack the shell to open[16]. Roasting process uses the rotating drum to heat the cashew.

#### B.1 Roasting drum

In the Roasting drum, the cashews are continuously fed in to the rotating drum from the cashew feeder, the fire is developed over the drum like a pan method, chimney is arranged with the drum to control the smoke evolved from the rotating drum [4]. The stepper motor connected with the drum used to rotate the drum along the heating process and the cashew nuts are roasted at a temperature of 80°C for the period of 4-5 minutes. PI controller desired the temperature value from the heating element and maintains the heating process stable condition for certain tome period.

#### B.2 Stepper motor

Usually stepper motor is widely used to convert the electrical form of energy into mechanical form of energy. In cashew processing stepper motor is placed in the roasting drum for the purpose of rotate the drum at a precise position and move the drum repeatedly [19]. However the stepper motor vary the

control depending on the various positioning applications. The speed and position control of the motor is given by the PI controller [14]. The motor torque function is necessary to move the load to drive based on armature circuit, rotor step rate and current through the windings [20]. The motor rotates along with the roasting process and has the speed of 40 rpm. In modelling uses the relay to positioning the rotor condition at the time of heating the stepper motor is on.

### C. Cutting process

In the cashew shelling process uses the servo motor to punch the cashew nut. Here the control the servo motor is given by the PI controller and PI controller is widely used as an ON-OFF controllers in many industrial applications[14][20]. After the roasting process delay will occur to cool the roasted cashew. Cooling process takes the period of 2-3 minutes then the roasted cashews are sent to the cashew shelling machine. The cashew are fed one by one using mechanical conveyor. Servo motor starts shelling operation by connecting the motor to the two blades are used to split the nuts by operating handle of cutter. Motor is used to cut the cashew nut and thus forces the shell to fracture without rupturing the kernel.

In modelling of cutting process uses the PWM signal as an input electric signal that rotates the rotary actuator, which allows the precise control of position, speed and acceleration under the control of PI controller with the speed of 90 rpm.

### D. Power led

When the set point is set, then the roasting process is to start at appropriate heating temperature and rotation of the motor will start. At this condition the Power LED is start switched on until the cashew shelling process.

### E. IR Sensor

IR Sensor is one of the electronic device and it works based on specific light sensor in the range of IR spectrum. In cashew processing IR sensor is used in the hardware implementation. It should be placed adjacent to the cutter to sense the cashew kernel output.

## IV. MATLAB/SIMULINK MODEL

The Matlab/Simulink tool is used to simulate the cashew processing without any hardware equipment's. Initially, the PI controller is designed using the matlab/Simulink library tools. After the PI controller is designed cashew roasting with rotation has to be designed under the control from the PI controller.

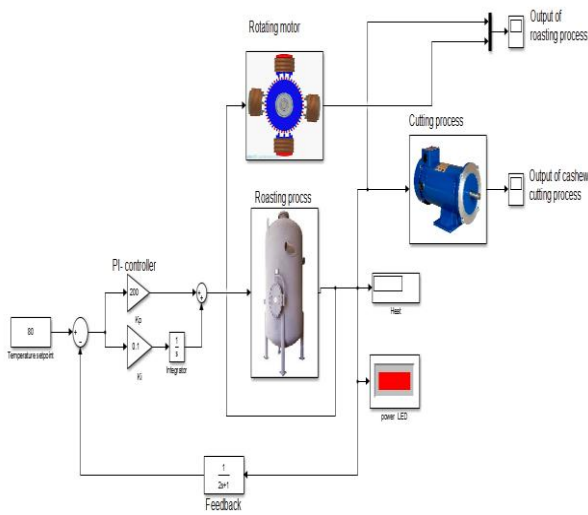

**Fig.5. Simulink model of domestic cashew nut cutting machine.**

The desired temperature is 80°C is set in the PI controller. In case the error will occurs means, the closed loop feedback path compensates the desired temperature and the output value. Along with heating process the stepper motor rotates with the speed of 40rpm for the time period of 4-5 minutes. After some delay, PI controller gives the control to the servo motor for cashew shelling process. Servo motor rotates with the speed of 90rpm. The Matlab/Simulink model of the proposed system is shown in Fig.5

In this Simulink model, after designing the PI controller connect all the subsystems of roasting drum, stepper motor and servo motor to the same. The feedback value acts as a sensor to compensate the value of the output temperature value and the input set point value. The power LED is connected adjacent to the roasting drum.

The complete design of domestic model Cashew cutting machine using MATLAB/SIMULINK simpower system tools. In PI controller output of the system is reference and the one or more output variable change in the system should follow the reference input value over the particular time. The controller manipulates the input values to a system to get the desired output. Here, use of feedback control system cancels out all errors during the entire operation and producing response in the output system.

**A. Flow chart**

The flow chart explains the overall design process of design and development of smart controller for domestic cashew shelling machine. Thus it gives the design flow of the cashew processing technique. The flow chart is designed with the specification of the each process involved in this research work.

Thus flow chart explains the overall design flow of the system. It describes that, at the initial condition PI controller is designed to control the various cashew processing techniques. Then the roasting process is designed which involves the roasting and rotating process. In the roasting process the cashews are roasted at a temperature of 80°C and the stepper motor will rotate at the 40 rpm.

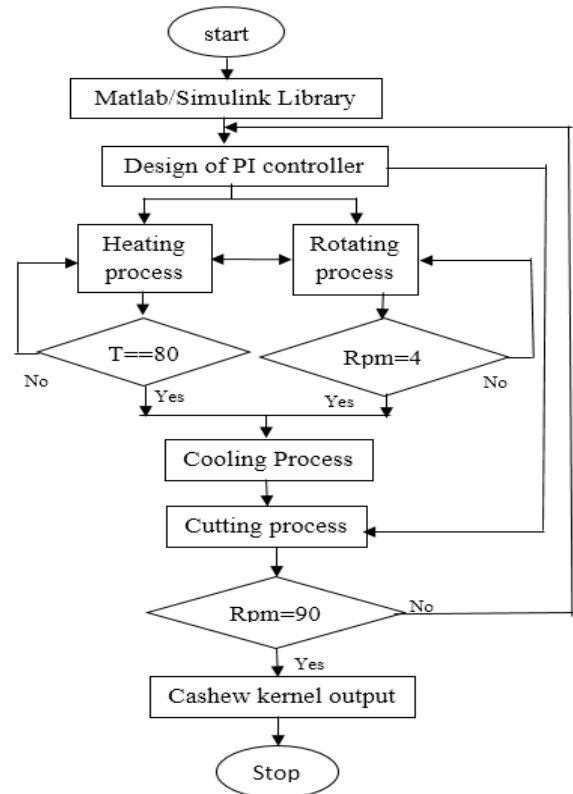

**Fig.6. Design of smart controller for efficient domestic cashew nut cutting machine**

After the roasting process, the roasted cashew nuts are placed in the cooling place for some time. Then the cashew shelling process is taken place to punch the cashew nuts. Shelling process uses the servo motor to extract the cashew from the cashew shell.

The flow chart for the design of smart controller for efficient domestic cashew nut cutting machine is shown in Fig 6.

Then the process continuously occurs for improving the production efficiency. The cashew nuts without broken sensed by the sensor are collected and in turn send to the cashew nut cutter for the removal of cashew shell from the cashew kernel.

**V. SYSTEM DESIGN**

The domestic cashew processing mainly consists of two process.

1. Roasting process
2. Cutting process

The design specifications of those process in MATLAB/SIMULINK is shown below.

The PI Controller is designed using the simpower system tools from the Simulink library tools to perform the roasting and cutting process of the cashews. It sets the certain temperature to roast the cashew and the control is established to systems such as drum, stepper motor and servo motor. For the motor functioning the input reference values are convert to electric pulses to rotate the motor shaft. The PI controller is designed using the specifications are given in Tab.1

**Table- II: PI controller specifications**

| S.NO | PARAMETERS        | VALUES |
|------|-------------------|--------|
| 1.   | Set point         | 80     |
| 2.   | Proportional gain | 200    |
| 3.   | Integral gain     | 0.1    |

Roasting drum used to heat the cashew with the certain temperature under the control from PI controller. And the threshold level of heating temperature is 80°C with the time period of 4-5 minutes. Motor is used to rotate the roasting drum. The PI controller gives the control to rotate the motor arm with load is designed by the Simulink library tools and the motor transfer functions are designed using the specification given in Tab.2.

In cashew shelling process, the servo motor is used to punch the cashew nut. The position of the servo motor arm is controlled by makes the input supply voltage is proportional to the error value. PWM signal is used to convert the input as voltage signal.

$$V_{\theta} = K_p e_{\theta} \quad (4)$$

Motor transfer function is given by the differential equation.

$$\frac{d\omega}{d\theta} = A\omega + B\theta \quad (5)$$

A and B are motor resistance and inductance constants. PI controller provides fast response times at high  $K_p$  settings. The servo motor specifications are given in Tab.3.

**Table .2. stepper motor specifications**

| S.NO | PARAMETER                        | VALUES                   |
|------|----------------------------------|--------------------------|
| 1    | R- Electrical resistance         | 2                        |
| 2    | L- Electrical Inductance         | 0.5H                     |
| 3    | $K_m$ -Torque constant           | 0.1(torque constant)     |
| 4    | $K_b$ -Back emf constant         | 0.1(back emf constant)   |
| 5    | $K_f$ - friction gain constant   | 0.2(Nms)                 |
| 6    | J-moment of inertia of the rotor | 0.02(Kg.m <sup>2</sup> ) |

**Table.3.Servo motor specifications**

| S.NO | COMPONENTS | PARAMETER                                 |
|------|------------|---|
| 1.   | PWM        | Switch on point-80<br>Switch off point-70 |
| 2.   | Gain       | 50  |
| 3.   | Resistance | 100                                       |
| 4.   | Inductance | 0.1                                       |
| 5.   | Input      | Step input of $\frac{\pi}{2}$ radians     |

## VI. RESULTS AND DISCUSSION

In this project PI controller is designed to perform the roasting and cutting process of the cashew. Proportional controller is used to eliminate the steady state error and cause overshoot problem. Gain of the Proportional controller will not completely reduce the steady state error so it adds an integral controller. The PI Controller is designed using the simpower system tools from the Simulink library tools to perform the roasting and cutting process of the cashew nut, here use the two gain functions as proportional and integral controller and use the integrator for the design of integral function. Set point is a constant value.

The PI controller provides the control to the roasting process for a certain time period. Ziegler-Nichols step response method is used to derive the transfer function model of roasting process. The power output of proportional controller is difference in the temperature being controlled and set point. The controller enabled to fully ON at the temperature is below the set point and the Fully OFF at the temperature above the set point. Thus the controller creates a proportioning band above and below set point. Integral component provides automatic and simultaneous elimination of offset between settling temperature and the set point.

The transfer function model in the matlab /Simulink model describes system responses, such as transient and steady state output. The proportional integral controller establish the continuous control to the process control. Gain functions of the controller gives the smooth relationship between input reference value such as electrical signal and the error function.

A servomotor used in the cashew cutting process is a rotary actuator that allows for precise control of angular or linear position, velocity and stimulation in the cashew processing uses the PI controller to establish the control to the motor arm. The torque generated by the servo motor is directly comparative to the armature current and strength of the magnetic field. The output waveforms of cashew roasting and cutting process is shown in Fig.7 and Fig.8

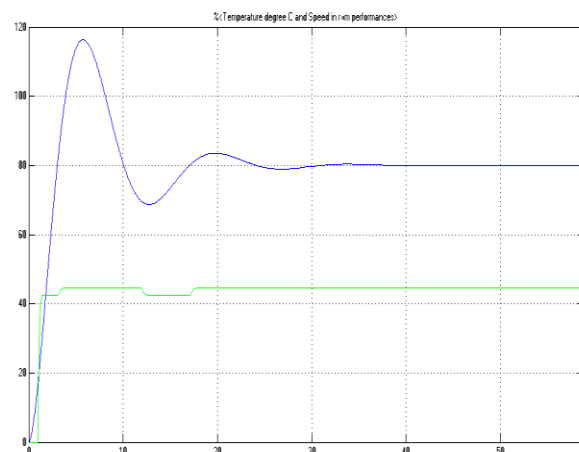

**Fig.7. cashew nut roasting process**

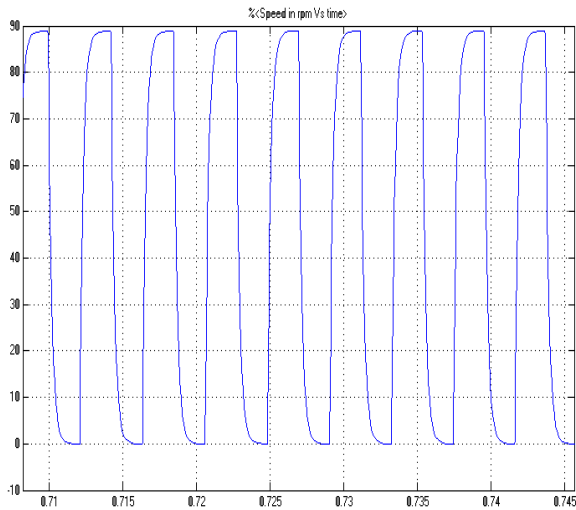

**Fig.8. Cashew nut cutting process**

## VII. CONCLUSION

This is the Design of smart controller for domestic cashew cutting machine and is implemented using MATLAB/SIMULINK tool without interfacing of any hardware equipment in it.

This model has given the complete result of the project and each component used in the system design where the results are seen in graph. First, the components used in the design are selected individually and are explained to show the working of the components. The components used here includes the PI controller, Stepper motor. Servo motor, sensor, LED are given. The connection to the PI controller with the roasting drum, interfacing of stepper motor with the PI controller and interfacing of servo motor with the PI controller is explained. The entire simulated output is then obtained by interconnecting the PI controller with all subsystems. Then the obtained model is used to reduce the man power and to improve the efficiency of cashew nut production for the user who are all need it domestically. The development of smart controller for efficient domestic cashew nut cutting machine is designed with low cost and small size.

## REFERENCES

1. Ajav E.A, "The design and testing of a low-cost cashew- nut cracker for peasant farmers, Tropical Agriculture", Vol.73, pp. 180-6 (1996).
2. Anon, "15% increase in EEC imports of indian cashew- Indian cashew journals". (1989).
3. Anonymous, "Cashew production technology. Technical Note", National Research Center forCashew, (ICAR), Puttur, Karnataka, pp: 12-34. (2009).
4. Azam-Ali, S.H. and Judge, E.C., "Small Scale Cashew Nut Processing, Food and Agricultural Organization of the United Nations", Rome (2004).
5. Babatunde Sunday Ogunsina. Adeleke Isaac Bamgboye .,Pre-shelling parameters and conditions that influence the whole kernel out-turn of steam-boiled cashew nuts, Journal of the Saudi Society of Agricultural Sciences (2014) 13, 2934 ( 2013).
6. Balasubramanian.D., "Optimization of processing parameters using farm level cashew nut processing" - j. Agric England (2007).
7. Cann B.,Baker I.,and Kuppelweiser., "An economic assesment of cashew production in northern territory top end-Technical Bulletin No.110" ,northern territory department of industries and development (1987)
8. Chacko E., Baker I., "Downton J.,towards a sustainable cashew industry for Australia"-Australia science (1990).

9. Davis, K., Cashew, Technical Note, ECHO, North Fort Myers, FL (1999).
10. Gill&Duffus., "Edible nut statistics-Gill & Duffu group London" ( 1989).
11. Jain, R.K. and Kumar. S, "Development of a cashew nut sheller, Journal of Food Engineering", Vol. 32, pp. 339-4 (1997).
12. Jadhav.R.A, "Economics of processing and marketing of cashew at household level in Ratnagiri district(MS)". Unpublished M.Sc.,-Thesis submitted to Dr.B.S.KonKan Krishi Vidyapeeth (2006).
13. Jim Fitzpatrick, "Cashew Nut Processing Equipment Study – Summary African Cashew initiative, Deutsche Gesellschaft für Internationale Zusammenarbeit (GIZ) GmbH International Foundations Postfach 5180, 65726 Eschborn", Germany (2011).
14. Kulkarni.S.D., "Energy use assesment in agro processing operation: factors to be considered for data collection for comparison". -J.agric England, (2000).
15. Mandal, R.C., Cashew (Anarcadium Occidentale L.), "National Research Centre for Cashew", Puttur (2002).
16. Ms.Manjusha Patil., "Modelling and simulation of dc drive using PI and PID controller., International journal of innovative research in electrical, electronics, instrumentation and control engineering",Vol. 2, Issue 12, December (2014).
17. Ogunsina BS and Bamgboye AI, "Fracture Resistance of Cashew Nuts as Influenced by Pre-Shelling Treatment, International Journal of Food Properties", 16(7): 1452-1459. (2013).
18. P.M. Meshram and Rohit G. Kanojiya, "Tuning of PID Controller using Ziegler- Nichols Method for speed control of DC Motor", March (2012).
19. Ojolo, S.J. and Ogunsina, B.S., "Development of a cashew nut cracking device, Agricultural Engineering International: The CIGR Ejournal", Vol. IX, June, Manuscript PM 06 030 (2007).
20. S.J. Ojolo, O. Damisa, J.I. Orisaleye and C. Ogbonnaya. "Design and development of cashew nut shelling machine", Mechanical Engineering Department, University of Lagos, Lagos, Nigeria (2009).

## AUTHOURS PROFILES



**First Author:Ms. R.Rubala** was graduated in Electronics and Communication Engineering in 2015 from Annai Teresa College of engineering, affiliated to Anna University, Chennai. She obtained his M.E degree from CK College of Engineering and Technology, affiliated to Anna University, Chennai, in 2017, specializing in Applied electronics, in Anna University, Chennai .She is in teaching profession for the past one year and six month. Currently, he is working as an Assistant Professor in Electronics and Communication Engineering Department at Jeppiaar Institute of Technology, Kunnam, Sriperumbudur, Chennai. His area of interest is embedded system,digital communication, Wireless Communication. Email Id: rubalar@jeppiaarinstitute.org



**Second author:** Benisha M is research Scholar of Anna University, department of Information and communication engineering, and working as a Assistant Professor, Department of ECE,Jeppiaar Institute of Technology She received her Master of Engineering in Communication System with Anna University Third rank. She attended more than 20 National/International conferences and published 32 papers in international journal among which 4 are indexed in WOS and 9 are indexed in Scopus. She is having more than 6 years of teaching experience. Her area of research includes 5G Antennas, mm – wave, Microstrip Patch Antennas. Email id: benishaxavier@gmail.com.



**Third author:M. Anisha** received her B.Tech in BioInformatics from Sathyabama University, Chennai in 2009, M.Tech in BioInformatics from Sathyabama University in 2011, and PhD in the area of Biosignal Processing from Noorul Islam Centre for Higher Education in 2018. At present, she is working as an Assistant Professor in the Department Biomedical Engineering, Kalasaligam Academy of Research and Education, Krishnankoil, India. Email id:anisha@alu.ac.in



**Fourth author: Mr. R. Thandaiah Prabu** was graduated in Electronics and Communication Engineering in 2007 from Paavai Engineering College, affiliated to Anna University, Chennai. He obtained his M.E degree from Alagappa Chettiar College of Engineering and Technology, affiliated to Anna University, Trichy in 2009, specializing in Optical Communication and currently pursuing his Ph.D., in Anna University, Chennai under the specialization of Millimeter Wave Antenna Design for 5 G Applications. He is in teaching profession for the past Nine years. Currently, he is working as an Assistant Professor in Electronics and Communication Engineering Department at Jeppiaar Institute of Technology, Kunnam, Sriperumbudur, Chennai. His area of interest is 5G Antennas, mm – wave, Microstrip Patch Antennas, UWB Antennas, Optical Networks, Wireless Communication. Email Id: thandaiah@gmail.com.