

# Design and Performance Analysis of Grid Connected Solar Power System by Fuzzy Control Algorithm



Shivaji Bhukya, S. Prakash

**Abstract:** In this paper we propose the fuzzy logic controller based solar fed grid via various loads. Normally present situation solar power play a vital role to meet the load demand. Solar power is the free from pollution and cost free fuel so in this paper I propose the solar based grid integrated framework, it consist of dc-dc boost converter, 3-phase voltage source inverter and fed to grid via various loads. MPPT based fuzzy logic controller is used to obtain the maximum power from the solar. But our proposed solar generation is intermittent in nature so before supplying this power to the load as well as grid we can control and enhance the power quality by utilizing FLC. This FLC control scheme effectively controls the harmonics developed in the grids. Current harmonics and Voltage flickers developed in the PV integrated grid due to non linear loads and critical loads present in the network. The proposed system is verified in MATLAB/SIMLINK.

**Keywords:** solar power; fuzzy control algorithm; MPPT; boost converter.

## I. INTRODUCTION:

Nowadays the role of electrical energy need is rapidly growing greater extent because of globalization and industrialization. Electrical Energy is highly needed for wide applications like agricultural applications, domestic application, and industrial applications. Without electrical energy no innovation is fulfilled. The greater challenge in front of every engineer is to reach the power demand. Power generation is by adopting conventional energy resources (produce power by combustion process) like coal, diesel, kerosene is causing environmental pollution and it may exhaust in future. So Now world looking about alternative methods to generate the power such as solar, wind, tidal and geo thermal etc. These renewable power generations PV is playing a crucial role since a decade.

Nowadays maximum power generation from conventional methods like thermal, hydro, nuclear etc..., this conventional sources emits the some gases that gases creates the pollution and its running cost is also high. These problems are overcome by utilizing our RES frameworks in that RES mainly in this paper we are consider photo voltaic cells. [1-4]. The power generation from solar is increasing very rapidly and very fast rate, the power generation from solar is free from pollution, zero running cost and less skilled labour is required.

Manuscript published on November 30, 2019.

\* Correspondence Author

Shivaji Bhukya, Phd Scholar Department Of Eee, Biher.  
Dr. S. Prakash, Professor, Department Of Eee, Biher Chennai

© The Authors. Published by Blue Eyes Intelligence Engineering and Sciences Publication (BEIESP). This is an open access article under the CC-BY-NC-ND license <http://creativecommons.org/licenses/by-nc-nd/4.0/>

In this proposed method our RES source is linked with grid and it might be operated as also standalone system in rural and remote areas to meet the load demand with help of battery energy storage systems. Photovoltaic frameworks are primarily categorised as two type's i.e.

Stand-alone and grid-integrated PV frameworks, in standalone only PV systems are operated and reach the load demand, In grid connected both PV and grid share the load demand.

The general representation of RES fed with grid as exposed in figure.1

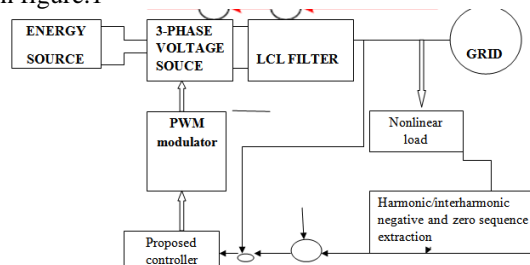


Fig.1. schematic of Energy sources integrated with Grid

The summary of proposed method is organized like in section 2 is exposed brief description about literature survey on PWM technique. In section 3 proposed system configurations. Finally chapter 4 and 5 is exposed about proposed method and brief discussion about simulation results.

- The main advantages of proposed method are enhancing the power quality in grid integrating solar frameworks by fuzzy logic controller.
- Reactive compensation in various loads.
- Efficient utilization of solar power by utilizing of MPPT algorithm.

## II. BACKGROUND WORK

The present research is going on mainly to enhance the power quality described various authors. That details description is exposed below. Ramakishan [8] has exposed the design of solar cell with single diode in MATLAB. The complete information about present of MPPT gave by Xuosong zhou [9]. Design of VSC based power electronic converter with novel digital controllers like fuzzy logic controller is talk about by Kelesidas.K [3] exposed about instantaneous power theory to compensate the reactive power. This theory consists of mitigation of and compensation of voltage and current related power quality issues for various linear and non linear loads.

In this paper the author is trying to generate the more power but every day the load demand will increase so if you want to meet the load demand the every research is choosing alternative solution, that solution is RES, but the 100 % utilization of this RES is not happening still. So in this our proposed method is try to extract the maximum power as well as enhance the power quality..

**III.CONFIGURATION OF GRID CONNECTED PV:**

The configuration of grid integrating solar framework is exposed in figure.2.

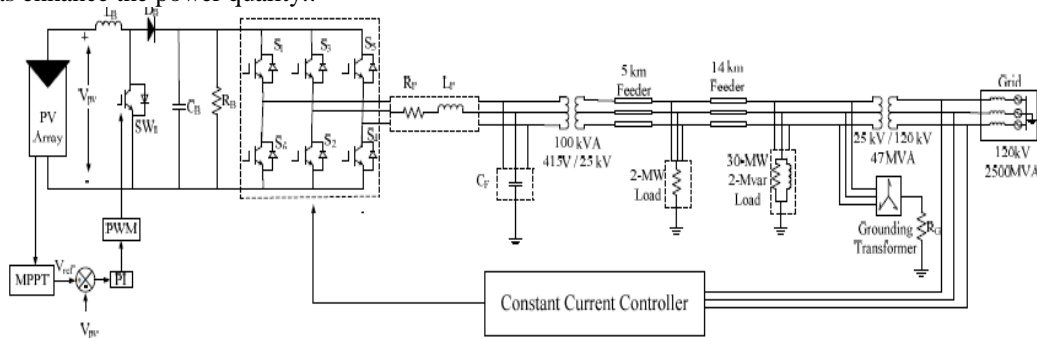


Fig.1 Configuration of the Grid integrated PV System

**Fig.2: Configuration of grid connected PV**

$$V_{parallel} = V_1 = V_2 = \dots = V_n$$

**A. Modelling Solar cell:**

Ideal Solar cell represents as current source (I<sub>ph</sub>) in parallel with Diode (D) and with Shunt (R<sub>sh</sub>) and series (R<sub>se</sub>) resistance. Voltage and current profile of PV is involves temperature (T) and irradiance (S). Power extracted from PV is known as

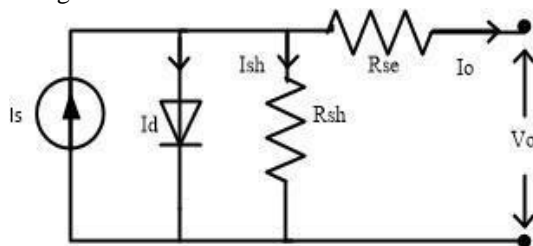
$$P=V \times I$$

The current created by the solar cell is equal to the current created by the current source minus the diode and shunt resistance current. The light generated current of Photo voltaic cell depends on the solar irradiation and the temperature is given an equations.

$$I = I_{ph} - I_s \left( \exp q \frac{(v + R_s I)}{NKT} \right) - 1 - \left( \frac{v + R_s I}{R_{sh}} \right)$$

**B. Solar Equivalent circuit:**

The equivalent circuit of the solar cell is shown as below fig.3.



**Fig. 3: Equivalent circuit of PV cell**

The voltages for n modules (PV array) in series are given as:

$$V_{series} = \sum_{j=1}^n V_j = V_1 + V_2 + \dots + V_n \text{ for } I > 0$$

$$V_{seriesoc} = \sum_{j=1}^n V_j = V_{oc1} + V_{oc2} + \dots + V_{ocn} \text{ for } I = 0$$

The current and voltage for m modules in parallel is given

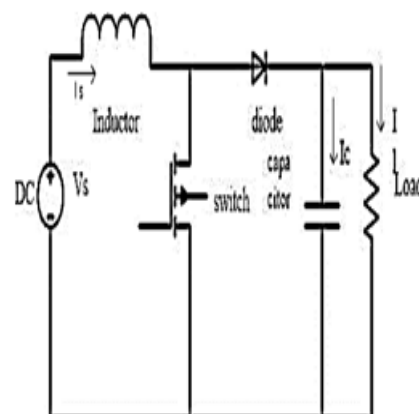
$$I_{parallel} = \sum_{j=1}^n I_j = I_1 + I_2 + \dots + I_n$$

**C. DC-DC Boost converter:**

In present situations our transformer less based PE converters played a vital role in conversion of voltage levels in RES based generations. In this proposed solar power fed grid systems, majorly we can consider our dc-dc converter to step up the voltages to increase the dc bus voltage after boost converter. The boost converter is consists of switch, diode, inductor and filter capacitor. In olden days the switching of this power electronic switch by duty ratio but we didn't get the desired output.

Now the all the research is concentrate on this switch controlling to obtain the maximum voltage. That is the reason we are utilizing MPPT algorithm to extract the maximum power from the solar and our PV panels are operating at desired irradiation.

The proposed boost converter is exposed in fig.4 the output voltage of solar is fed to the series inductor (L<sub>s</sub>).



**Fig.4. DC-DC Boost converter circuit**

The firing of switch is by PWM fed by MPPT algorithm. When the switch ON the source is short circuited and in that the inductor will be charged and after next cycle the power electronic switch will be switched off then the position of switch is open circuit.

The source is directly fed to the load through inductor. The generalized formula for boost converter is exposed under below.

$$\frac{V_o}{V_{pv}} = \frac{1}{1-D}$$

**D. Maximum Power Point Tracking (MPPT):**

Present situations utilizing of RES sources are very difficult task, in that manner the efficiency of PV cell is less and as well as fluctuating in nature. The irradiation is also varying according to atmosphere in that situation utilizing and extract the solar power is main task. So the present research is utilizing of MPPT algorithm to obtain the maximum power.

This MPPT is fed to the boost converter to extract the peak power. Various P-V and PV cell are exposed in fig.5.

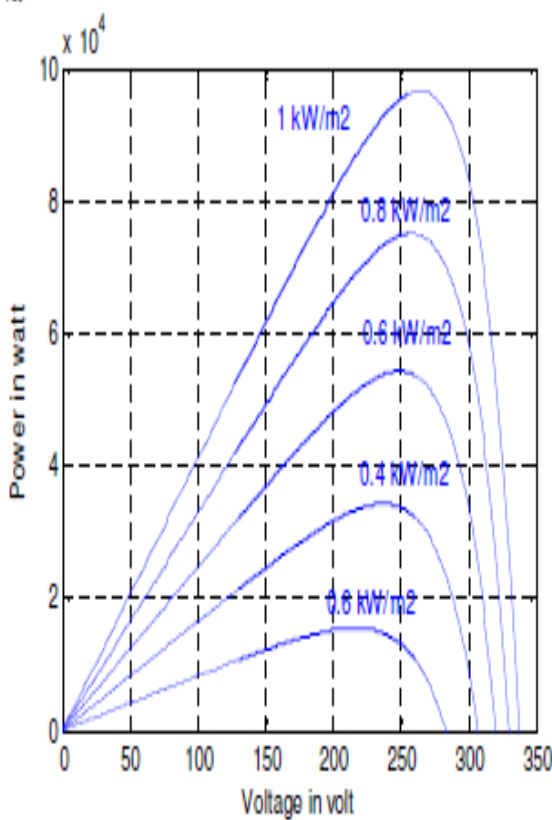


Fig. 5: P-V characteristics of the PV cell.

From the above curves compared to all curves initially getting the voltage zero and final value also zero but if we control the algorithm of MPPT we can achieve the maximum power point. Generally we are various MPPT algorithms are present that's basically and fundamentally P&O second one is incremental conductance and third one is hill climbing method.

Output generate from output terminals of the solar cell is given as

$$P = V \times I$$

The general characteristics of solar cell is non linear in nature so in this proposed method we are utilizing the incremental conductance method based MPPT algorithm.

The same manner we can conduct various times to achieve peak point so that we achieve the maximum power

from the solar. The general flow chart for getting maximum power is exposed in fig.6.

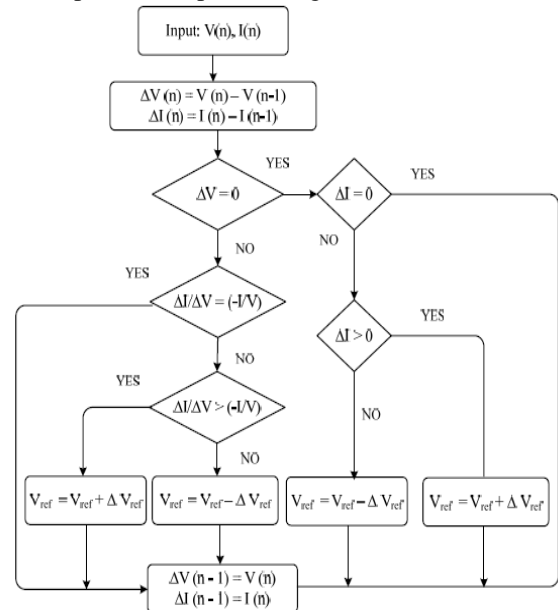


Fig. 6: Flow chart diagram for incremental conductance method

**IV. PROPOSED METHOD:**

The proposed system is fuzzy logic controller based solar power integrating with grid. Conventionally this system is controlled with conventional PI controller, the design of PI controllers are very easy and simple in construction and sluggish in response and accuracy is very less because the gain values are obtained by trial and error method. But in case of proposed method getting results more accurately, very fast in response and robotics.

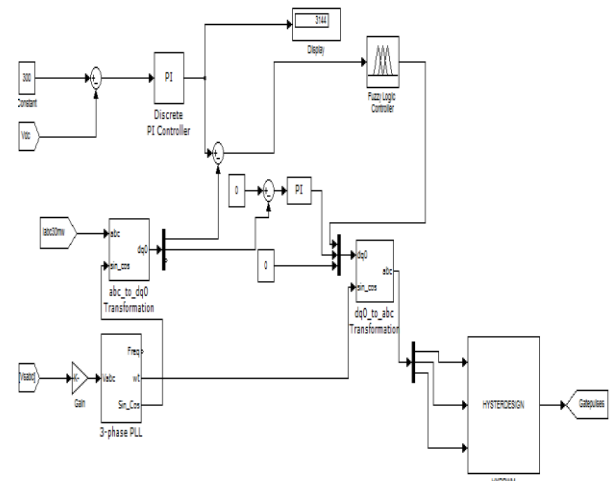
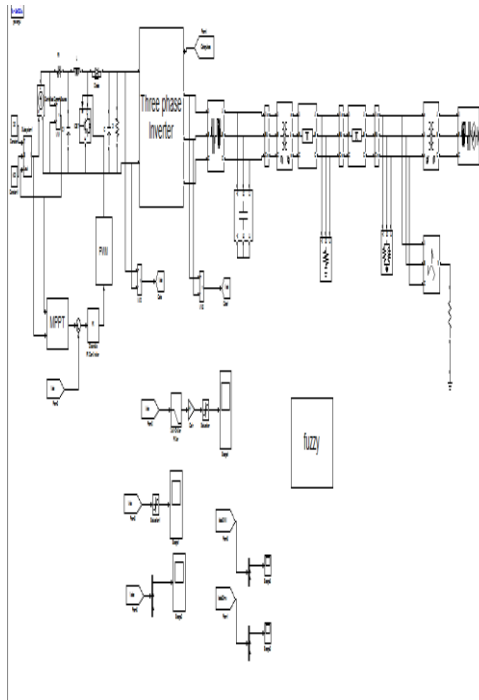


Fig.7. Proposed Control scheme

**V. Simulation Results:**

The MATLAB modelling of proposed PV integrated Solar is shown in figure.8 as below.

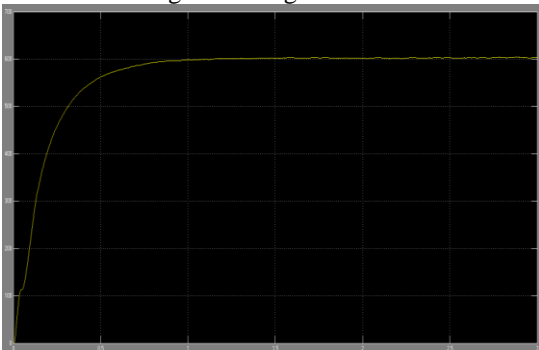
# Design and Performance Analysis of Grid Connected Solar Power System by Fuzzy Control Algorithm



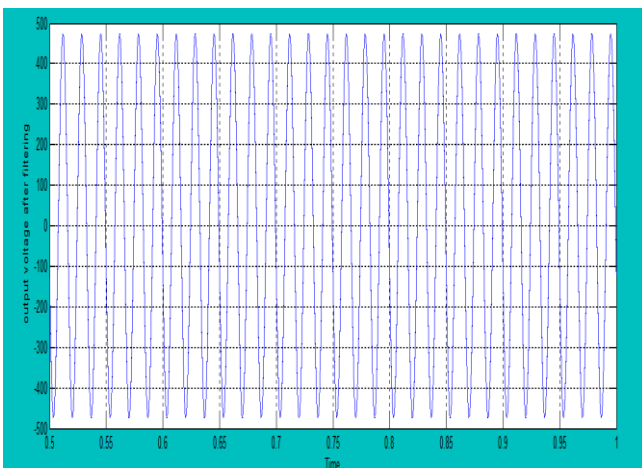
**Fig.8.** Model of PV integrated grid system

The proposed method simulation results are exposed below at different load conditions. Mainly in this method we are operating the system at 2MW load and as well as 30MW load.

Figure no.9 will expose the output dc bus voltage, the waveform clearly expose our solar system is generating 600v dc after utilizing MPPT algorithm at boost converter

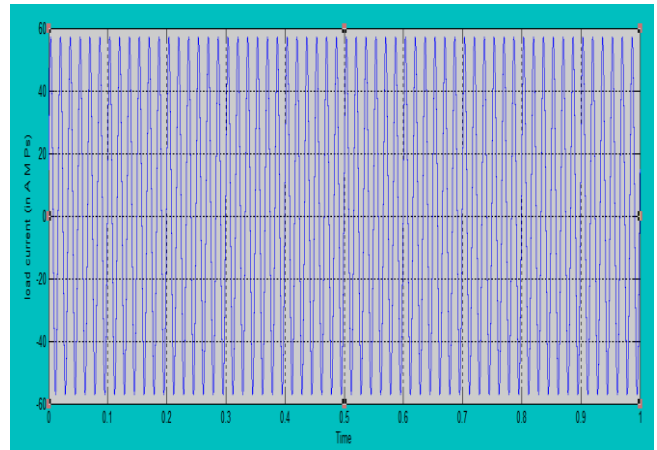


**Fig. 9** DC voltage delivered by the boost converter

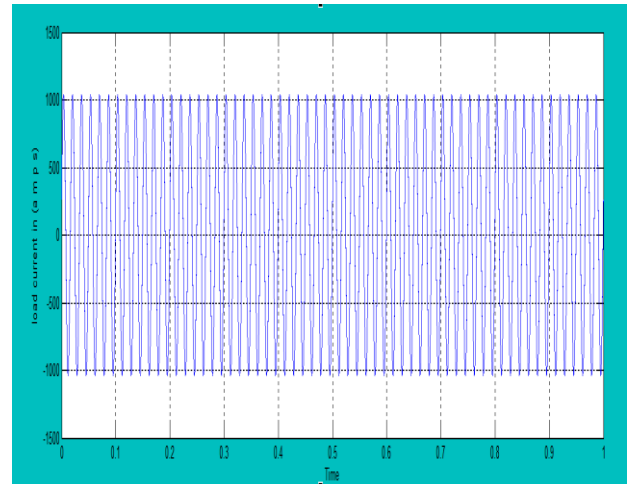


**Fig.10** output voltage after filtering

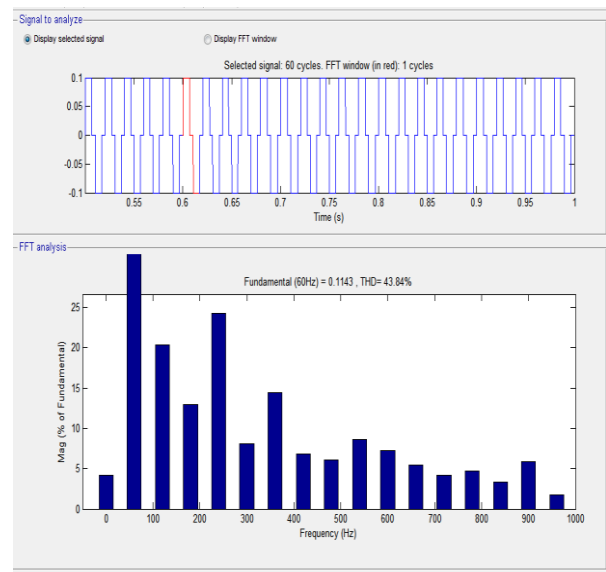
Figure 10 is exposed waveform of output voltage after filtering it clearly exposed after filter we receive the output is pure sinusoidal waveform that clearly expose enhancing the power quality.



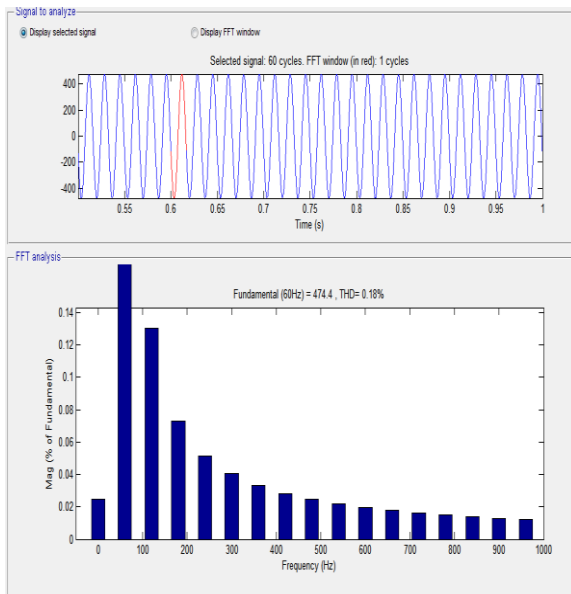
**Fig.11** Load current for supplying 2MW load



**Fig.12** Load current for supplying 30MW load, 2 MVAR



**Fig.13** THD wave form of voltage before filtering



**Fig.14** THD waveform after filtering of voltage.

From figure no.13 and 14 are exposed reducing % THD from 43.54 to 0.18 this shows compensation of harmonics and enhance the power quality.

### VI.CONCLUSION:

In this proposed paper we are modelling and simulation of fuzzy logic controller based grid integrated PV framework is utilized for enhancing the power quality by mitigating the harmonics in the system. This proposed technique expose the compensation of total harmonic distortions diminishes and enhances the power quality compare with FLC controllers these functions will be proven in MATLAB/SIMLINK, and also we can get the maximum power from solar by utilizing the MPPT.

### FUTURE SCOPE:

In this paper we are just concentrating on grid connected solar power generation with fuzzy logic controller, in future we can implement this proposed method with hybrid power generation like wind, fuel cell etc..., and also with novel digital controllers like nuero fuzzy, ANN and also with wavelet controllers.

### REFERENCES:

1. Bidyadhar subudhi, Raseswari Pradhan, "A Comparative study on maximum power point tracking techniques for photovoltaic systems,"IEEE transactions on sustainable energy., vol.4, no.1,pp. 89-98,January2013.
2. Huajun Yu, Junmin pan, anxiang, "A multifunction grid connected pv system with reactive power compensation for the grid, "science direct-solar energy ., vol.79, pp. 101-106, 2005.
3. Kelesidas.K, Adamidis.G, Tsengenes.g, "Investigation of a control scheme based on modified p-q theory for single phase single stage grid connected PV," pp.535-540.
4. Jinjun liu, jun yang, Zhaon Wong, "a new approach for single phase grid connected harmonic current detection and its application in hybrid active power filter."
5. Peter Gevorkian., Large scale power system design.USA, 2011.
6. Prabha K.,Malathi T.,Muruganandam M, "Power quality improvement in single phasegrid connected nonlinear loads", vol.4, no.3, pp. 1269-1276, 2015.
7. Hongpeng Lie, SHingong jing,wng wei,"maximum power point tracking based on double index model of PV cell," pp.2113-2116, 2009.

8. Rama krishan, Yang raj sood, Uday Kumar, "Simulation and design for analysis of photovoltaic system based on mat lab," pp.647-651, 2011.
9. Xuosong zhou, daichun song, Youjie ma, cheng deshu, "simulation and design based for MPPT of PV system based on incremental conductance method", international conference on information engineering, pp.314-317,2010.
10. S. Charles, G.Bhuvaneswari,"Comparison of Three Phase Shunt Active Power Filter Algorithms,"International Journal of Computer and Electrical Engineering., vol 2,no.1,pp.175-180,Feb 2010.
11. N. C. Sahoo, I. Elamvazuthi, Nursyarizal Mohd Nor, P. Sebastian and B. P. Lim," PV Panel Modelling using Simscape,"pp.10-14,2011.
12. N. Femia, G. petrone, V. Spagnuolo, M. Vitelli, 'Optimization of Perturb and Observe maximum Power Point Tracking Method', IEEE Trans. on Power Electron., Vol. 20, No. 4, July 2005
13. Y. Zhihao, W. Xiaobo: 'Compensation loop design of a photovoltaic system based on constant voltage MPPT'. Power and Energy Engineering Conf., APPEEC 2009, Asia-Pacific, pp. 1- 4, March 2009.