

Segmentation and Classification of Image Abnormalities in Retinal Fundus using Discrete Wavelet Transforms



V.Devi, D.Ravikumar

Abstract- Glaucoma disease diagnosis greatly based on the accurate retinal image segmentation and classification of images. Segmentation means to divide the images into a patchwork of regions, each of which is “homogeneous”, that is the “same” in some sense. Using discrete wavelet transform, the segmented images are classified by Support Vector Machine (SVM) classifiers to classify the Glaucoma images. The proposed Support Vector Machine classifier is used to extract the information rely on the Region of Interest (ROI) from original retinal fundus image. Thus the classification result are used to find the normal and abnormal image and also to compute the normal and abnormal accuracies. We observed an accuracy of around 93% using data set by SVM classifier.

Keywords: Biomedical optical image, Glaucoma, Feature extraction, Fuzzy C-means (FCM), Discrete Wavelet Transform (DWT), Gaussian Filter, Support Vector Machine (SVM).

I. INTRODUCTION

The second foremost advancing optical disorder is Glaucoma after cataract causation relating to the degenerative Optic Nerve Head (ONH) structure. It causes irreversible vision loss, if it is untreated on time. Regardless to the diversified ample quantity of data are ready to use for detecting glaucoma, the interpretation of primitive tests for diagnosis are quite inadequate to minimize the risk of visual loss and impairment. As glaucoma is asymptomatic, the patients are unaware until noticeable vision loss occurs. Due to its insidious nature, it is very important to detect glaucoma at the earliest. Moreover, glaucoma primitive findings is significantly important as long as it allows early analysis, thereby preventing serious vision loss and capable of prolonging useful vision. The analysis of glaucoma detection comes through the different cues in image, almost all the medical examiners consider a Cup-to-Disc Ratio (CDR) as a significant factor. Due to the neurological and physiological factors the lacking of visual perceptions leads to the blindness conditions..

The major global causes of blindness conditions exist due to cataract (48.7%), glaucoma (13.2%) and macular degeneration related to age (9.8%), Opaqueness of cornea (5.2%) and other causes like onchocerciasis (0.8%) like so on. In the field of medical diagnosis, this proposed work is used for reducing stress and time which is experienced by the ophthalmologist and other members of the team in screening, diagnosing using digital image processing for the treatment of glaucoma

II. RELATED WORKS

EH Galilea et.al [1] (2007) proposed their work on diagnosing the glaucoma by employing artificial intelligence in Artificial Neural Network (ANN) systems, that incorporates the analysis of the retinal nerve fibers with scanning laser perimetry, polarimetry, and clinical studies. R. Varma et al [2] (2008) proposes the second foremost advancing optical disorder in worldwide is due to the progressive optic neuropathy characterized by a loss of retinal nerves of ganglion cells and the regular age-related baseline loss based on their axons. K Huang et.al [3] (2008) explained the distribution of energy over the sub bands of discrete wavelet is a widely used feature for wavelet packet based texture classification.

J Nayak et.al [4] (2008) suggests an increase in the intraocular pressure in the retinal optic nerve of the eyeball. i.e. (cup size) cause a glaucoma diseases. U. R. Acharya et.al [5] (2008) put forth the retina is impaired due to various inflammatory disorders including fluid leakage from the retinal blood vessels resulting Diabetic Retinopathy (DR) that causes blindness of the patient. M. Balasubramanian et.al [6] (2009) proposes Glaucoma is the second foremost causes for the blindness throughout the world. Frequent increase of pressure within the eyeball results in damage to the optical disk and gradual loss of vision is often due to the Optic Nerve Head (ONH) and changes happens prior to visual field loss which can be observed in vivo therapy.

R. George et al [7] (2010) conveyed the commonness of glaucoma disease over a period of last decade has been chronicled by the, Andhra Pradesh Eye Disease Study, Vellore Eye Survey, Aravind Comprehensive Eye Survey, West Bengal Glaucoma Study and Chennai Glaucoma Study.

J. M. Jimenez et.al [8-13] (2010) the present medical analysis for glaucoma detection can be done through the Multi-Focal Electro Retino Graphy (MFERG) recordings can be developed on standard morphological signal, estimating latencies and amplitudes.

Manuscript published on November 30, 2019.

* Correspondence Author

Dr.V.Devi, Department of Computer Applications, Gurunanak College, Chennai, India. Email: vdevi78@yahoo.com

Dr.D.Ravikumar*, Department of Electronics and Communication Engineering, Vels Institute of Science Technology & Advanced Studies, Chennai, India. Email: ravi.se@velsuniv.ac.in

© The Authors. Published by Blue Eyes Intelligence Engineering and Sciences Publication (BEIESP). This is an [open access](https://creativecommons.org/licenses/by-nc-nd/4.0/) article under the CC-BY-NC-ND license <http://creativecommons.org/licenses/by-nc-nd/4.0/>

III. PROPOSED WORK

The proposed work involves a part of the process to develop and validate a method that can automatically segment optic disk and blood vessels in the retinal fundus image. The figure1, describes the process of our proposed work to determine the classification process in retinal fundus image. The steps are as follows.

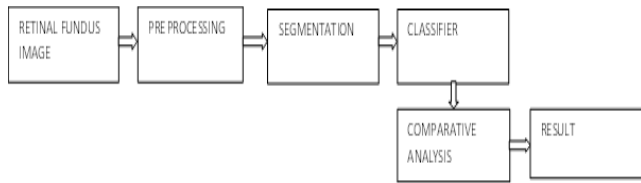

Figure1. Block Diagram for the proposed work of Retinal fundus.

Image acquiring

The images of retinal fundus are acquired from the DRIVE database. The Fundus camera is a device used to capture the photographic of a retinal image. It works on the principles of indirect ophthalmologic, where the fundus camera is being used instead of observer’s eye.

Preprocessing

The acquired fundus image is to be preprocessed since it has no noise. Here we have chosen Gaussian filter. The process of removing the exterior part of an image to enhance framing, changing aspect ratio or to emphasize subject matters is referred as Image cropping. Images are cropped using the MATLAB function imcrop(), which provides us the quality of being easily performed to investigate a specific region of interest. The build-in image crop function “effectively removes borders from image whose pixel value distribution is almost uniform“. Brightness point is used for cropping the image in fixed point.

Wavelet Transform

Wavelet transforms are used to change the composition of the signal into another representation thereby presenting the signal information in a more useable form. This change in the composition of the signal is known as the wavelet transform. In mathematical terms the convolution of wavelet function with the signals is referred as a wavelet transforms. Jean Morlet et.al, formulates the wavelet functions as a family from translations and dilations of a single function called as the "mother wavelet" $\psi(x)$. This is outlined by an equation as:

$$\psi_{j,k}(x) = \frac{1}{\sqrt{|j|}} \psi\left(\frac{x-k}{j}\right) \quad j,k \in \mathbb{Z}, j \neq 0$$

.....equation (3.1)

An element ‘ j ’ is the scaling parameter or arbitrary constant as a process of measuring the degree of compression. The element ‘ k ’ is an arbitrary constant of translation parameter which is used for determining the wavelet time location. In the equation 3.1 when $|j| < 1$, then the wavelet is in the compressed form i.e (smaller aid in the time domain) of the mother wavelet which relates to the higher frequencies. From an alternative point of view, if $|j| > 1$ besides, $\psi_{j,k}(x)$ possess a larger time width while $\psi(x)$ relates to the lower frequencies.

Discrete Wavelet Transform

Wavelet being a family of primary function generated by translations and dilations of a fundamental filter functions. The wavelet functions are formulated by the basis of an orthogonal functions and the DWT is thus a decomposition of the original signal into constituent parts in terms of the basis function (Mallat et. al,):

$$f(x) = \sum_{m=0}^{\infty} \sum_{n=0}^{\infty} C_n^m U_{m,n}(x)$$

.....equation (3.2)

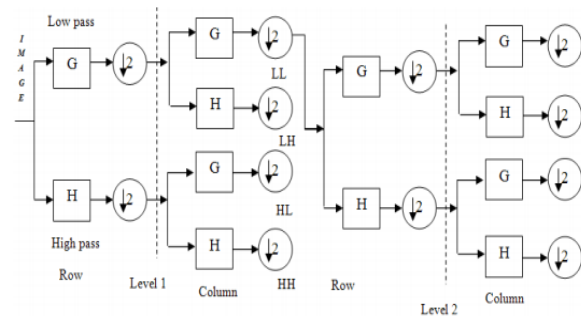

Figure 2: 2-Level DWT of Images

Where, $U_{m,n}(x) = 2^{-m/2} U(2^{-m} x - n)$ are dilations and translations of the basic filter function $U(x)$. Unlike the composition of sine and cosine functions has an infinite length in the Fourier base. The basis wavelet functions have a limited duration. Estimating the signal components of a discrete wavelet transform coefficients C_n^m are focus at $(2^m n, 2^{-m})$ and can be measured by the inner products of $U_{m,n}(x)$ and $f(x)$ in the time frequency plane.

Segmentation

The process of partitioning an image into an indefinite number of parts where each holds its own property is referred as segmentation of a microarray image. Here the clustering methods are used for retinal fundus image segmentation.

Spatially Weighted Fuzzy C-Means Clustering Algorithm(SWFCM)

The SWFCM is applied within the images in which blood vessels are already blurred. A major attribute of an image is that they are highly correlated with the neighboring pixels. In clustering technique since the spatial correlation is most dominant but it is a not employed in common Fuzzy C-means algorithm. And hence the optic cup region obtained from FCM does not show the complete contour.

The SWFCM is used to utilize the spatial information’s, and a spatial function is given by the equation:

$$h_{ij} = \sum_{k \in NB(x_j)} u_{ik} \quad \text{..... equation(3.3)}$$

where $NB(x_j)$ denotes a square window focused on the pixel x_j in spatial domain. The large size window may blur the images and the small size window does not remove the high density noise respectively. Hence, an optimal window size 5x5 is used in this proposed work.

As similar to membership function, the pixel x_j denotes the probability of the spatial function h_{ij} belonging to the i^{th} cluster. If the majority of the neighboring pixels belong to the same clusters then the spatial function of pixels will be large. When the membership function was incorporated with the spatial function as a result the following equation exists:

$$u'_{ij} = \frac{u_{ij}^p h_{ij}^q}{\sum_{k=1}^c u_{kj}^p h_{kj}^q} \dots\dots \text{equation (3.4)}$$

where p and q are the controlling parameters for both the functions. The clustering results do not change in the homogenous region since the original membership function is strengthening by the spatial functions. Although the present formulae reduces the weight of a noisy cluster in noisy pixels by the labels to its neighboring pixels. As a result, the spurious blobs or misclassified pixels from noisy region can be assessed in an easy manner.

The clustering is a two pass operations for every iteration. The first pass is identical and typically same as the of standard FCM to compute the membership functions. In the second pass, the each pixel membership information is mapped to the spatial domain and its function is determined from that. The FCM iteration yields a new membership that is incorporated with the spatial functions.

The iteration is stopped when the two clustering centers are compared with the maximum difference between at two successive iterations is less than 0.0001. The defuzzification is applied for each pixel to a specific cluster following the convergence for which the membership is maximal.

Data set

After the segmentation process the data of the images are stored and used for the classifier to find the normal and abnormal images.

Classifiers

Once the features are set, the classifiers are used to find the normal and abnormal images. Herethe Support Vector Machine classifier is used to find the image from the data set.

Support Vector Machine

The Support Vector Machines (SVM),also Support Vector Networks in the machine learning are supervised with an associated learning algorithm for a data analysis and the pattern recognition are implemented for classification and regression analysis. For example each training set, belonging to one of two categories, an SVM training algorithm builds a model and allocates a new example into single category, by making a non-linear probabilistic binary classifier. For example a Support Vector Machine representation model in the space is mapped, so that the examples of the separate categories are divided into a clear gap i.e. as wide as possible. New examples are then mapped into the same space and predicted to a category based on which side of the gap they fall on.

In addition to effectuate linear classification, the SVMs can efficiently execute a non-linear classification using the kernel trick, implicitly maps with a high-dimensional feature spaces in their inputs.

IV. RESULTS

Figure 3.shown below is the Retinal Fundus image acquired from the drive database.

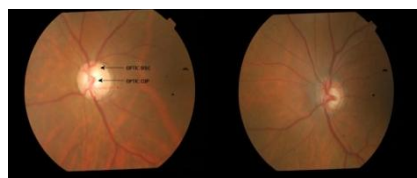

Figure 3.(a) Normal Image Figure 3.(b) Abnormal Image

Figure 4.shown below is the conversion of RGB image to Gray Scale image for our convenience of processing.

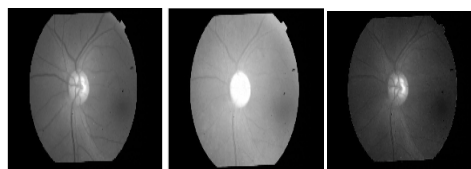

Figure 4 (a) R channel Figure 4 (b) G channel Figure 4(c) B channel

Figure 4.Gray Scale Image

Figure 5, shown below is the cropped and segmented image after filtering.

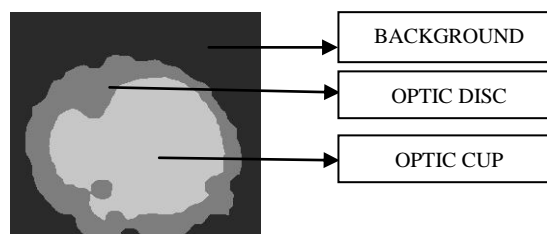

Figure 5.Segmented Image

Figure 6,shown below is the fully segmented optic cup. Optic cup is segmented by using ROI image in this proposed work. In this paper the spatially weighted cup.

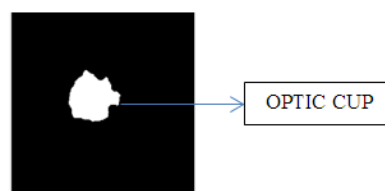

Figure 6.Optic cup

Table 1. Data set that are correctly classified for SVM

Type of Image	Number of Data Sets Used for Testing	Correctly Classified Test Data	Percentage Correctly Classified (%)
Normal	7	7	100%
Glaucoma	7	6	85.71%
Average			92.85%

Table 1 shows the result and accuracies of the Dominant Rotated Local Binary Patterns (DRLBP) features for glaucomatous image classification by using SVM. In order to classify an unknown retinal fundus images into normal/abnormal, the SVM classifier is used to incorporate normal/abnormal features. It is also used for obtaining better classification results. The fact finding results exhibits that the proposed system achieves maximum classification accuracy average is 92.85%

V. CONCLUSION AND FUTURE WORK

In terms of the utilization the SVM classifier is our default classifier for its good performance. It follows a given training sample set and a test sample. We can compare the input test sample with all the training samples via the measurement of discrepancy and assigns the class label for the closest training sample to it. The accuracy of the classification average is 92.85%.

The Classification of this work can be implemented to find the Normal and Abnormal test images separately from the unknown test images based on Features and also to compute the normal and abnormal accuracy. In Segmentation process various techniques may be used for future work, in order to segment the optic disk and optic cup. The final result would be the Normal and the glaucoma detection is based on Cup to Disc Ratio (CDR).

REFERENCES

1. Choy et al. : Supervised texture classification using characteristic generalized Gaussian density: Journal of Mathematical Imaging and Vision : : 2007: Vol:29 : No.1: pp. 35-47
2. Li, L., Tong, C. S., & Choy, S. K.:Texture classification using refined histogram”, Image Processing : IEEE Transactions on : : 2010 : Vol.19, No.5, pp. 1371-1378
3. Choy, S. K., & Tong, C. S.:Statistical wavelet subband characterization based on generalized gamma density and its application in texture retrieval : Image Processing, IEEE Transactions on : 2010 : Vol.19, No.2, pp. 281-289
4. Kim, S. C., & Kang, T. J :Texture classification and segmentation using wavelet packet frame and Gaussian mixture model : Pattern Recognition : 2007 : Vol.40, No.4, pp. 1207-1221.
5. Le Borgne, et al . : Learning midlevel image features for natural scene and texture classification : Circuits and Systems for Video Technology, IEEE Transactions on: 2007:Vol.17,No.3,pp. 286-297
6. Lategahn et al :Texture classification by modeling joint distributions of local patterns with Gaussian mixtures: Image Processing, IEEE Transactions on : 2010 : Vol.19, No.6, pp. 1548-1557
7. Guo, Z., Zhang, L., & Zhang, D : A completed modeling of local binary pattern operator for texture classification : Image Processing: IEEE Transactions on : 2010 : Vol.19, No.6, pp. 1657-1663
8. Acharya et al : Automated diagnosis of glaucoma using texture and higher order spectra features: Information Technology in Biomedicine : IEEE Transactions on: 2011: Vol.15, No.3, pp. 449-455
9. Brown et al : Structural and functional imaging of the retina: new ways to diagnose and assess retinal disease : Clinical and Experimental Optometry : 2008 : Vol.91, No.6, pp. 504-514
10. Huang et al: Wavelet feature selection for image classification. Image Processing : IEEE Transactions on : 2008 : Vol.17, No.9, pp. 1709-1720
11. J. Nayak : AutomatedDiagnosis of glaucoma using digital fundus images : J. Med. Syst : 2009 : Vol. 33, No. 5, pp. 337-346
12. D. Bizios et al : Trained artificial neural network for glaucoma diagnosis using visual field data: A comparison with conventional algorithms : J. Glaucoma : : 2007 : Vol. 16, No. 1, pp. 20-28
13. M. Balasubramanian et al : A framework for detecting glaucomatous progression in the optic nerve head of an eye using proper orthogonal decomposition : IEEE Trans. Inf. Technol. Biomed : : 2009 : Vol. 13, No. 5, pp. 781-793

AUTHORS PROFILE

Dr.V.Devi is currently working as Dean & HOD for the Department of Computer Applications, Gurunanak College, Chennai-India.

Dr.D.Ravikumar, is currently working as HOD & Assistant Professor for the Department of Electronics & Communication Engineering, Vels Institute of Science, Technology & Advanced Studies, Chennai-India