

# Overall Development in the Application of Ultracapacitor and Controller in Electric Vehicle

Akshay A. Kakde, Shrikrishna G. Tarnekar



**ABSTRACT---** *This paper deals with stepwise development in hybrid electric vehicle based on battery source and ultracapacitor. The focus is on the utilization of ultracapacitor and sustainable development in a hybrid vehicle application. Various control strategies to improve utilization of ultracapacitor has been studied and represented here.*

**Keywords:** *Ultracapacitor, Electric vehicle, DC-DC controller, Battery, PHEV*

## I. INTRODUCTION

World Health Organization (WHO) has reported that New Delhi, India has been the most polluted city in the world [1] as per conclusion from 2014 data [2-3]. Air pollution is mostly due to vehicles. Use of vehicles is increasing very rapidly in India from the last two decades, which causes more and more air pollution[4], in New Delhi [5-7].

To reduce pollution due to the use of conventional fossil fuels, electric vehicles must be popularized. From the last few decades, hybrid electric vehicles are attracting more attention since they help us in reducing pollution levels[8]. Government of India also takes steps towards more utilization of electric vehicles mainly in the area of transportations. Distribution of e-Riksha at low cost is one of the efforts taken by the Government of India in various states[9].

As an essential first step, the introduction of the ultracapacitor is needed. Article [10] gives a brief history and development of ultracapacitor. To explore the field of an ultracapacitor-based hybrid electric vehicle, it is essential to understand the background of electric vehicle and stepwise development in it. Also, it is necessary to understand the role of ultracapacitor and its control systems which are mostly based on different types of DC-DC converters. To know these controllers, it is necessary to know in brief about the background of the DC-DC controller.

## II. BACKGROUND OF ULTRACAPACITOR

Paper relates within electrochemical capacitor (EC) called as ultracapacitor or Supercapacitor. Since the late 1800s, the store of electrical energy in the supercapacitor has been known and H.I. Becker of General Electric (U.S. Patent 2,800,616) reported first electrical appliance using ultracapacitor charge storage was reported in 1957(the device was impractical). The commonly used format is attributed by Robert A. Rightmire at the SOHIO (Standard Oil Company of Ohio) in 1962 and registred in U.S. patent (U.S. 3,288,641) and a consequential patent (U.S. Patent 3,536,963) by Donald L. Boos in 1970. Many other related successive patents and articles which covers all aspects of ultracapacitor technology. In 1978, with the license of SOHIO ultracapacitor used commercially but as back-up power devices for volatile clock chips and complementary metal-oxide-semiconductor (CMOS) compute memories. The next development in an ultracapacitor is as follows, in 1962 by electrochemical capacitors at SOHIO, followed by electrochemical capacitors at NEC in 1975 as well as electrochemical capacitors at econd in 1975, then in 1978 Panasonic take step towards EC at Panasonic, EC at elit in 1988, thenElna in 1989and at maxwell in 1991.EC also at Esma in 1993, EC at cap-xx in 1994, then at Nippon Chemicon in 1995, followed byNesscap in 1998.

## III. DEVELOPMENT IN ELECTRIC VEHICLE

In the last 25 years, many other applications have emerged like, power generation, power quality, industrial actuator power sources, portable wireless communication, electric vehicles (EVs) energy storage and hybrid electric vehicles (HEVs).

In hybrid electric vehicles, many challenges were identified and resolved. But the idea of implementation of ultracapacitor takes a longer time for acceptance [11]. In this, compression between battery and ultracapacitor was majorly debated. The article gives one important keep that, the basic differences between electrochemical capacitors and batteries are due to their structures/functions. The difference in their materials/structures and in physical/chemical mechanisms dependents on functions [12]. The battery stores energy chemically and capacitor stores its charge electrostatically. The battery has much higher energy density and undergoes physical change between the charged and the discharged state.

Manuscript published on 30 September 2019

\* Correspondence Author

**Akshay A Kakde\***, Ph.D. Scholar, Department of Electrical Engineering G. H. Raisoni College of Engineering Nagpur, India. (E-mail kakde\_akshay.ghrcephdee@raisoni.net)

**Shrikrishna G. Tarnekar**, Retired Professor, Department of Electrical Engineering G.H.Raisnoi College of Engineering Nagpur, India.(E-mail sgtarnekar@gmail.com)

© The Authors. Published by Blue Eyes Intelligence Engineering and Sciences Publication (BEIESP). This is an [open access](https://creativecommons.org/licenses/by-nc-nd/4.0/) article under the CC-BY-NC-ND license <http://creativecommons.org/licenses/by-nc-nd/4.0/>

## Overall Development in the Application of Ultracapacitor and Controller in Electric Vehicle

Whereas capacitor has a low density as compared to the battery but very little change in material structure with charge state. The important outcome of the article is information on which ultracapacitor has been taken into consideration as a storage device. The next difference is between charge and discharge time of battery and ultracapacitor. The time required for ultracapacitors for charging and discharging is in seconds. On the other hand, the battery takes time in minutes or in hours to get charge and discharge. The next difference is given in terms of energy storage and the life cycle of battery and ultracapacitor. Advantage of battery is the chemical changes that give cycle life for deep discharge and some batteries provide 5,000 cycles or more than that. The ultracapacitors life cycle is in terms of hundreds, thousands or in millions of cycles, whereas batteries life cycle is in hundred and thousands of cycles. Paper also comments on today's advanced batteries. These are more efficient and have high power capability without any major de-rating. But in heavy hybrid vehicles, an ultracapacitor is the most promising energy storage device as is suggested in the paper. One example of heavy truck operation is also mentioned in the paper.

The challenges for any energy storage and high-life-cycle are required for heavy hybrid vehicles due to heavy heat dissipation during charging and discharging. Ultracapacitors are well-suited for heavy hybrid vehicle applications because of high efficiency and life cycle. The major difference between batteries and ultracapacitor used in electric vehicles was clearly indicated in Figure.1 [10].

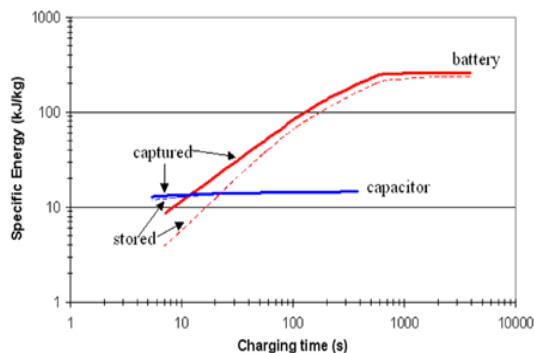

**Figure.1. The specific energy difference between Batteries and ultracapacitor**

In the next stage, various papers are reviewed, which deals with the application of ultracapacitor in the hybrid electric vehicle [13]. The focus of the paper is on the sizing of the ultracapacitor unit and energy utilization. Cost and size reduction of the ultracapacitor unit is taken into consideration [14]. Next paper was revised to understand development in electric vehicle (EV). This paper deals with the electric vehicle history. In 1834, the electric vehicle was invented in America but not commercially used. In America, France, and Britain, a number of companies produced electric vehicles in the 19th Century. Due to restrictions of batteries utilization, and fast development in the ICE (internal combustion Engines) vehicles, Electric vehicles almost vanished from 1930 to 1970. Due to the energy crisis in the 1970s, USA government (1976) announced the Research, Development, and Demonstration of the Electric

and Hybrid Vehicle Act, Public. In 1998, successful run from Los- Angeles to Detroit gives big confidence to EV industry and relative developers. Continued with the review process in the development area, developed stages have been studied [15]. So, various development stages are explained in brief. In the first stage, Classification of electric vehicles is represented in Figure.2.

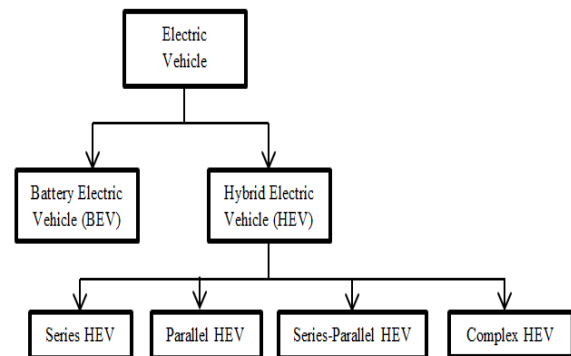

**Figure.2. EVs Classification**

In 1881, Frenchman Gustave Trouvé built the first electric vehicle. It was a battery (lead-acid) based having 0.1 HP DC motorcycle driven an electric vehicle. Figure. 3 shows a schematic diagram first EV.

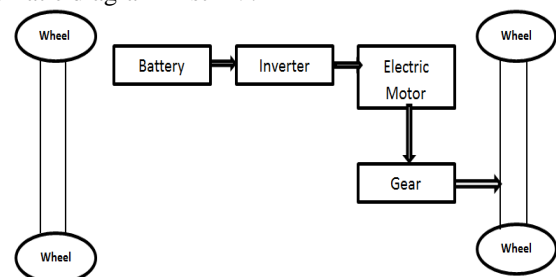

**Figure.3. Electric Vehicle**

Paper says there were many advantages electric vehicle compared to the conventional ICE vehicle, such as reducing the emissions, high efficiency, and smooth operation. In Paris salon (1898), one-step-ahead has been taken. The first hybrid electric vehicle (HEV) has been introduced by Pieper (Belgium) and Vendoveli (France) in coordination with Priestly Electric Carriage Company, France. Figure 4 shows a hybrid electric vehicle.

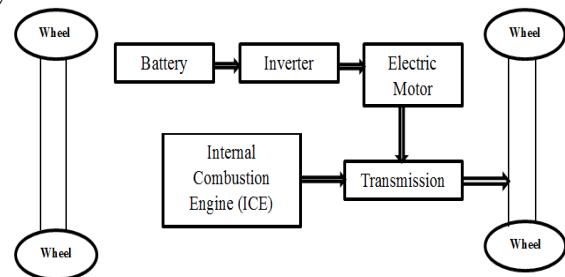

**Figure.4. Hybrid Electric Vehicle**

The next Hybrid electric vehicle, that is series HEV introduced in the Paris Salon (1899) and followed with parallel HEV, Series-Parallel EHV, Complex EHV, Fuel cell HEV and then Plug-in HEV.

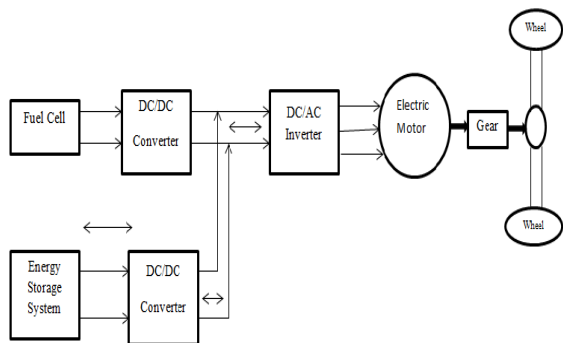

Figure. 5. Fuel cell HEV.

In 1839, Sir William Grove (The Father of the Fuel Cell) discovered the possibility to generate electricity by reversing the electrolysis of water, and further development happened up to 1932, which is done by Francis Bacon to successive development of fuel cell. On the basis of the above-reviewed topic, review process shifted towards the implementation of ultracapacitor in replacement of fuel cell. For that, some more paper has been reviewed. In the next paper [16-17], application of ultracapacitor in Electric Hybrid Vehicles has been studied. In this paper, the author gives details explanation regarding the implementation of ultracapacitor in combination with battery to drive motor.

Next paper [18] deals with AES (auxiliary energy system), which is designed for electric vehicles. For better efficiency of operation, an experimental model was presented. As AES device, an ultracapacitor is used. The DC-DC converter is also implemented in the circuit. In the first case, a battery (lead-acid) replaces the fuel cell. In the next case, ultracapacitors were used in combination with lithium batteries for evaluation of power support systems. As, per the paper, results show a cost decrease at the rate when ultracapacitors were used. The developed system is represented in Figure.6.

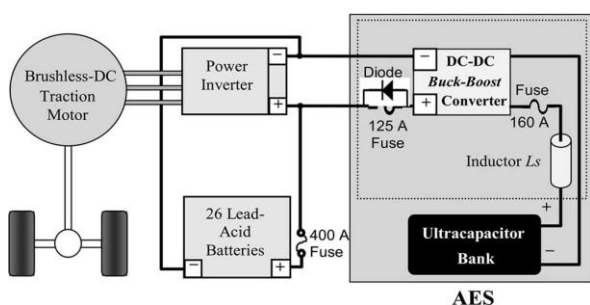

Figure. 6 Parallel combinations of battery and ultracapacitor for the motor load.

The next reviewed paper[19]is useful to identify and understand various batteries characteristics and helpful for the selection of battery for the proposed scheme. The comparative analysis is shown in Figureure 7.

	Capacity (Ah)	Voltage (V)	Resistance (mΩ)	W/kg 95%eff	Usable SoC
NiMH					
Panasonic	6.5	7.2	11.4	207	40%
Ovonic	12	12	10	195	30%
Saft	14	1.2	1.1	172	30%
Li-ion					
Saft	12	4	7.0	256	20%
Shin-kobe	4	4	3.4	745	18%
Lead-acid					
Panasonic	25	12	7.8	77	28%

Table.1. Characteristics of Commercial Batteries ForHev Applications

IV. IMPLEMENTATIONOF DC - DC CONVERTERS IN HEV & RESULTS

In the next part of the paper, authors are dealing with DC-DC converter and energy management system (EMS). From all mentioned topologies, one topology designed as an inaccessible converter with a transformer for charging and discharging of batteries. Then dual active bridge converter was designed as represented in Figure. 8. In this topology, the left side bridge works as an inverter while energy delivering from the converter to the battery. The right side bridge was used to invert power from DC to AC while discharging of the battery. By operating phase shift of two half bridges, zero-voltage switching were obtained. This allows lossless snubber capacitances a resonant discharge. before conduction of the switching devices, Each anti-parallel diode was conducted and the circuit uses the leakage inductance of the transformer as an interface between the two half-bridge converters. Dual active bridge system provides fast control with high power density. Furthermore, Some more DC-DC converter has been reviewed.

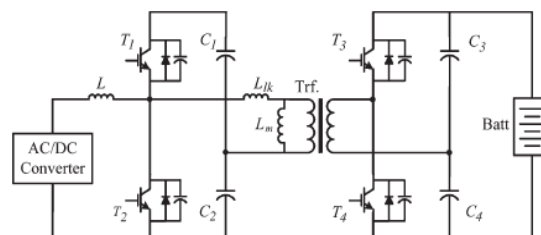

Figure 7. Dual-active-bridge dc/dc converter

Basic dc-dc converter circuit [20] i.e. bucks converter and boost converter is reported in Figure. 8 as a schematic diagram. In this, buck converter was used with a switching network for dropping voltage dc component and switching harmonics. An SPDT (single pole double throw) switch is used for circuit operation. For position 1 of the switch (Figure 8), switch output voltage  $V_s(t)=V_g$ . But at position 2,  $V_s(t) = 0$ .

The switching frequency ( $f_s$ ) is equal to  $1/T_s$ . Paper suggests semiconductor devices such as BJTs, power MOSFETs, diodes, IGBTs used as SPDT switch. Now, a factor which equals to D (duty cycle), where  $0 \leq D \leq 1$  and  $V_s \leq V_g$  (Figure. 9).The power dissipated  $P_D=0$  (Ideally). Hence,  $V_s(t) = 0$ , Therefore  $P_D= 0$  if contacts of switch

# Overall Development in the Application of Ultracapacitor and Controller in Electric Vehicle

were closed. To remove harmonics low pass filter was implemented. The diagram is shown in Figure 8.

$$V_s = \frac{1}{T_s} \int_0^{T_s} v_s(t) dt = DV_g \quad (1)$$

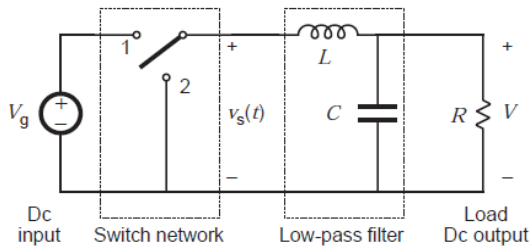

Figure 8. Switch network of the buck converter

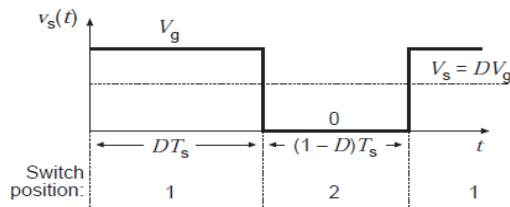

Figure 9. switch voltage waveform.

The corner frequency  $f_0$  given by

$$f_0 = \frac{1}{2\pi\sqrt{LC}} \quad (2)$$

The  $M(D)$  conversion ratio is given as

$$M(D) = \frac{V}{V_g} \quad (3)$$

The  $M(D)$  for the buck converter is given as

$$M(D) = D \quad (4)$$

In the next step, the boost converter is explained in detail.

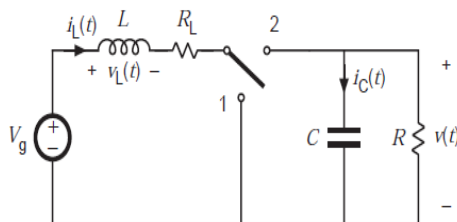

Figure 10. The buck converter Schematic diagram

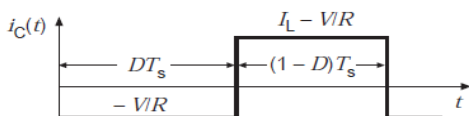
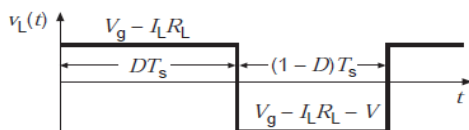

Figure 11. switch voltage waveform.

Initially, the switch is in position 1. At this position, inductor circuit stores some energy. Then the switch is shifted to position 2. when the total energy supplied to the load is the same as the sum of source energy and energy store in the inductor circuit during switch at position 1. The total boosting is dependent on total energy storing capability of the inductor circuit. This paper gives a brief idea of buck, boost, and buck-boost converter. By using this information, a constant output voltage based DC-DC converter has been developed for simulation purpose. Next paper[21] deals with combination battery with ultracapacitor to extend battery life cycle during utilization for an electric vehicle. The author also focuses on sizing and hybridization of battery and ultracapacitor. For optimizing power flow between ultracapacitor and battery, an energy management strategy has been proposed and implemented.

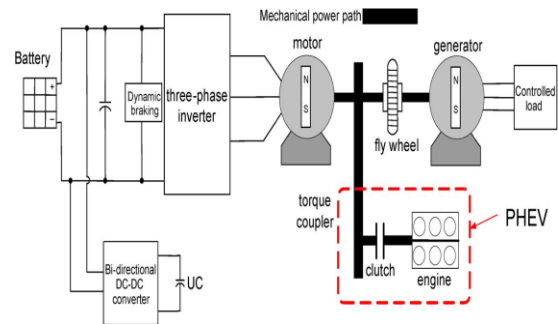

Figure. 12. EV/parallel PHEV system configuration.

The topology is shown in Figure. 12, we concentrated on the parallel combination of battery and ultracapacitor with DC - DC converter. The UC and battery providing energy to load requirements during normal running conditions. However, during a ride through the condition, the peak energy requirement may increase the capability of the battery and ultracapacitor. During this condition, engine power was used for the required power.

The power  $P_{veh}$  has equal to the sum of the battery power ( $P_{BU}$ ) and the UC power ( $P_{UC}$ ). Another paper[22] which comments on power utilization topology between ultracapacitor and battery.

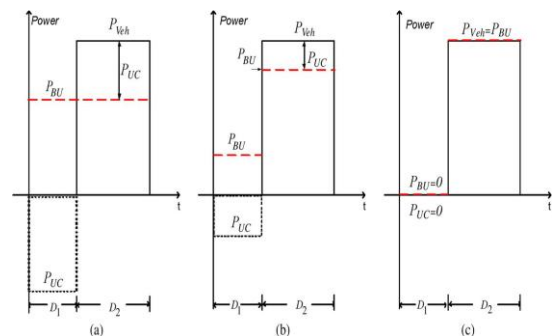
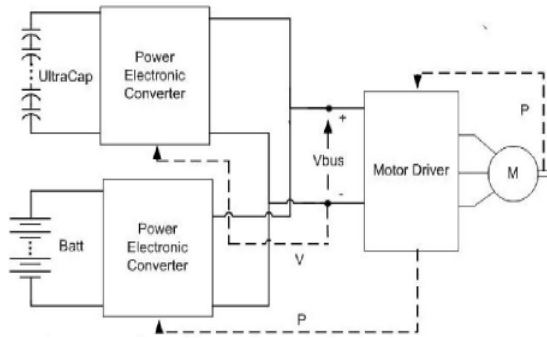

Figure 13. BU power ( $P_{BU}$ ) and vehicle power ( $P_{veh}$ ) at dissimilar DHs. (a)  $DH = 1 - D_2$ . (b)  $0 < DH < 1 - D_2$ . (c)  $DH = 0$ .

An optimizing method for energy storage, operation of a battery/ultracapacitor for a hybrid energy storage system (HESS) has been reviewed here. The outcome of the paper is the utilization of the power of battery and ultracapacitor for a smaller energy storage system.



**Figure. 14. Bi-Directional (Two-input) DC-DC Converter**

As many topologies explained in this paper, from all this, bi-directional (two input) DC-DC converter system having more stability and efficiency. In this topology, it is assumed that the same power is extracted from UC and battery SoCs. The voltage level of both DC - DC converters is maintained the same but the current is distributed amongst them. It is shown that HESS (passive) can supplies 3 times more battery power during pack condition.

Battery energy saving based paper deals[23] in the direction of saving and expand the life of the battery. Paper gives a brief idea about loading condition of. In this manuscript, simulation is done on Matlab and ANL (Argonne National Laboratory) 's Autonomie software. This system was confirmed by HIL (Hardware in the Loop). In result, the author demonstrates a significant expansion of 76% of battery life was achieved by reducing HESS with 72 ultracapacitor cells. Similar paper[24] based mainly focuses on battery life extension, which is done by applying battery and ultracapacitor parallel combination. Paper also gives an idea about various advancements in the battery-operated system. The advancements of battery are given as, Smoothing of the Battery Current, Vehicle Range Extension, Low-Temperature Operation, battery lifetime improvement, etc. The cycling experimentation of the system shows that up to 40% lifetime extension of battery might be possible in combination ultracapacitor.

Paper [25] which is helpful to understand and provides a basic idea about the algorithm of control system has been studied. In this paper, ultracapacitor (SC) is initially charged about 90% of State of Charge (SoC). But Paper clearly indicated that SC is utilized up to 60% of SoC. During this utilization of SC, 50% of the load is shared by SC and 50% load is on battery. The author indicates the mode of energy management i.e. long term management and short term management. For this system, a small value of the load is used for experimentation work. That compromises battery life.

## V. CONCLUSION

In the hybrid Electrical vehicle, use of ultracapacitor is increasing and expected to be more popular in the coming years. Large scale production of HEVs starts to appear in the market. There are a number of control categories available

for HEVs. The adoption of a particular control technique depends on a number of factors, such as expected performance output, economy, and energy efficiency. Battery-ultracapacitor based parallel HEV and its control strategies have been studied and taken into consideration of new topology approach.

Currently, it seems that, even with parallel hybrid vehicle technology, the utilization of ultracapacitor having a scope of improvement. However, the control system for ultracapacitor energy also having the opportunity for better efficiency.

## REFERENCES

1. DebosreeGhosh and PratapParida, " air pollution and india: current scenario ", International Journal of Current Research Volume 7, Issue 11, pp. 22194-22196, November 2015.
2. Pollution Externalities and Health: A Study of Indian Rivers] pdf
3. Pravin Singare<sup>1</sup>, Ram Lokhande<sup>2</sup>, Pragati Pathak<sup>3</sup>, " Soil Pollution along Kalwa Bridge at Thane Creek of Maharashtra, India ", Journal of Environmental Protection, 2010, volume.1, pp. 121-128.
4. S. K. Goyal<sup>1</sup>, S.V. Ghatge<sup>2</sup>, P.S. Nema<sup>3</sup> S.M. Tamhane<sup>4</sup>, " Understanding urban vehicular pollution problem vis-a-vis ambient air quality-case study of a megacity (Delhi India) ", Environmental Monitoring and Assessment, volume. issue 119, pp. 557-569, 2006.
5. S. K. Guttikunda<sup>1</sup>, R. Goel<sup>2</sup>, P. Pant, "Nature of air pollution, emission sources and management in the Indian cities", Atmospheric Environment issue 95, pp. 501-510, 2014.
6. S. Rizwan<sup>1</sup>, B. Nongkynrih<sup>2</sup>, S. Gupta<sup>3</sup>, " Air pollution in Delhi: Its Magnitude and Effects on Health.", Indian J. Community Med. issue 38, pp 4-8, 2013.
7. A.S. Nagpure<sup>1</sup>, B.R. Gurjar<sup>2</sup>, "Development and evaluation of Vehicular Air Pollution Inventory model", Atmospheric Environment, issue 59, pp.160-169, 2012.
8. Colin JR Sheppard<sup>1</sup>, Anand Gopal<sup>2</sup>, Andrew Harris<sup>3</sup>, Arne Jacobson<sup>4</sup>, "Cost-effective electric vehicle charging infrastructure siting for Delhi", Environ. Res. Lett. 11, 064010 open access, 10 June 2016.
9. Nisha Chandran<sup>1</sup>, Samir Kumar Brahmachari<sup>2</sup>, " Technology, knowledge, and markets: connecting the dots electric rickshaw in India as a case study ", Journal of Frugal Innovation, Springer open access, 2015.
10. John Miller<sup>1</sup>, Andrew Burke<sup>2</sup>, "Electrochemical Capacitors: Challenges and Opportunities for Real-World Applications", The Electrochemical Society Interface, page 53-57, Springer, 2008.
11. John Miller, " A Brief History Of Supercapacitor, Batteries, And Energy Storage Technology " Autumn, pp 61-78, 2007.
12. B Conway, " Transition from "Supercapacitor" to "Battery" Behavior in Electrochemical Energy Storage", J. Electrochem. Society ,issue 138, page 1539, 1991.
13. C.C. Chan, "Electric Vehicles", Proc. IEEE, Encyclopedia of Life Support Systems (EOLSS) – Vol. III, University of Hong Kong, China.
14. P. Sivachandran<sup>1</sup>, P. Lakshmi<sup>2</sup> and M. Kalichemy<sup>3</sup>, "A State of the art review of Electric and Hybrid Electric Vehicle Technology with recent developments in the globe", Department of Electrical and Electronics Engineering, SneeSastha Institute of Engineering and Technology, Chennai, India.

15. Andrew Burke, Hengbing Zhao, "Applications of Supercapacitors in Electric and Hybrid Vehicles", Research Report – UCD-ITS-RR-15-09, Institute of Transportation Studies, University of California, Davis, April 2015.
16. Liu, Z., "The Use of Ultracapacitors in Hybrid Vehicles", Master's Thesis, University of California, Davis, Transportation Technology and Policy Program, August 2014.
17. Micah Ortuzar<sup>1</sup>, Jorge Moreno<sup>2</sup>, Juan Dixon<sup>3</sup>, "Ultracapacitor Based Auxiliary Energy System for an Electric Vehicle: Implementation and Evaluation", IEEE Transactions on Industrial Electronics, Volume 54, issue 4, Pp. 2147-2156, August 2007.
18. A. Khaligh<sup>1</sup>, Z. Li<sup>2</sup>, " Battery ultracapacitor fuel cell and hybrid energy storage systems for electric hybrid electric fuel cell and plug in hybrid electric vehicles: State of the art", *IEEE Trans. Vehicle Technol.*, volume. 59, issue 6, pp. 2806-2814, Jul. 2010.
19. Robert Erickson, "DC-DC Power Converters", Article in Wiley Encyclopedia of Electrical and Electronics Engineering, Department of Electrical and Computer Engineering, University of Colorado, Boulder, CO 80309-0425.
20. L. Wang<sup>1</sup>, E. G. Collins<sup>2</sup>, H. Li<sup>3</sup>, "Optimal design and real-time control for energy management in electric vehicles", *IEEE Trans. Veh. Technol.*, volume 60, issue 4, pp. 1419-1429, May 2011.
21. S. Lukic<sup>1</sup>, S. Wirasingha<sup>2</sup>, F. Rodriguez<sup>3</sup> J. Cao<sup>4</sup>, A. Emadi<sup>5</sup>, "Power management of an ultracapacitor/battery hybrid energy storage system in anhev", *Proc. IEEE VPPC*, pp. 1-6, Sep. 2006.
22. Junyi Shen<sup>1</sup>, Serkan Dusmez<sup>2</sup>, AlirezaKhaligh<sup>3</sup>, " Optimization of Sizing and Battery Cycle Life in Battery / Ultracapacitor Hybrid Energy Storage Systems for Electric Vehicle Applications", IEEE Transactions On Industrial Informatics, July 2014.
23. Bogdan Vulturescu<sup>1</sup>, Stéphane Butterbach<sup>2</sup>, Christophe<sup>3</sup>, " Experimental Considerations on the Battery Lifetime of a Hybrid Power Source Made of Ultracapacitors and Lead–Acid Batteries", IEEE Journal Of Emerging And Selected Topics In Power Electronics, Volume. 2, issue 3, September 2014
24. Felipe Machado<sup>1</sup>, João P. F. Trovão<sup>2</sup>, Carlos Henggeler Antunes<sup>3</sup>, "Effectiveness of Supercapacitors in Pure Electric Vehicle Using a Hybrid Meta-Heuristic Approach", IEEE Transactions On Vehicular Technology, 0018-9545, 2015.