



Development of Automatic Poultry System (Quails) using Arduino Microcontroller

Arman Hadi Azahar, Muhammad Azizi Ismail, Rozilawati Mohd Nor, Mohamad Haniff Harun, Amar Faiz Zainal Abidin, Mohd Badril Nor Shah, Khalil Azha Annuar

Abstract: *The main purpose of the development of automatic poultry system (quails) using Arduino microcontroller. Quail farmers face problem to maintain or increase their livestock due to high mortality rates during the changes of quail growth phase. The mortality rates mainly affected by uncontrolled climate change of the environment. Therefore, this project is developed to helps broiler quail farmers to maintain their livestock with less supervision from them. At the same time, ensuring stable growth rates and reducing the mortality rates affected from uncontrolled climate/environment factor which is temperature, surround air quality, and intensity of lights is the main focus of this project. In controlling the temperature, air quality, and intensity of light, the DHT11 humidity and temperature sensor, MQ135 air quality sensor, and TSL 2561 digital luminosity (lux) sensor used in this project along with Arduino microcontroller to maintain and control those climate/environment factor at specific range of parameters so that it satisfies with quail growing phases. As the result, it shows that by implement this project can increase performance growth and reduce the mortality rates of the quail compare to conventional method. The retrieved data from the project prototype system and actual experiment is then been analyze, evaluate and kept for further improvements.*

Keywords : *Automatic poultry system (Quails), Automatic quails coop, Integrated farming, Commercialize Broiler Quails Poultry.*

I. INTRODUCTION

Commercial quail poultry has three main sectors which laying, broiler/meat, and parent stock/hatchery quail poultry. In Malaysia, commercialize quail poultry have start since 1981 but the percentage of the farmer who work on it at that instant time is very low cause of difficulty of getting a quail

breed. After experiencing, improvement from Department of Veterinary Malaysia, Institut Kemajuan Ternakan Ayam (IKTA) has come with a new quail high quality breed which correspond to the local climate named as IKTA in conjunction with the successful of IKTA’s experimental studies [1] [2]

Besides IKTA, there are some species of quail that has been commercially grown in Malaysia such as *Bob White* from United States of America (USA), *Coturnix Japonica* from Japan, and *Cross Bred* from local area [3] [4].

This project is focusing on development of automatic poultry system (quails) by using Arduino microcontroller and several sensor such humidity and temperature sensor, TSL2561 luminosity/lux sensor and MQ135 air quality sensor. This project will automatically control the custody of quail livestock such controlling surrounded temperature, light intensity of surrounded coops, and ventilation system.

To control temperature of surround coops, this project will use DHT11 temperature and humidity sensor together with the cooling fan and ceramic heating lamp to sense, control and maintain surround temperature at specific level. When temperature applied is not corresponding to quail ages, it will decrease the quail appetite [4].The ideal temperature for quail aged from 1 day to 3 week is from 30°C to 37°C [3].

In controlling the surround air quality, this project used MQ135 air quality sensor in order to trigger the ventilation system when the air quality index (AQI) value is exceed the limit. For the purpose of controlling the supplied light intensity, the brightness of the LED flood lamp will be controlled by the TSL2561 digital luminosity/lux sensor until it meet the specific level of light intensity (lux). As the conclusion, this project produces advantages for quail farmers to maintain the livestock with less supervision while leaving and granting the maximum level of custody and can provide optimal livestock growth rate and also can reduce the mortality due to uncontrolled climate effect.

II. RESEARCH METHODOLOGY

A. Developing Project Control Structure

The suitable parameter for these three element that need to be implement in this project which focused on the broiler quail poultry are shown in Table I.

Table- I: Parameter range of controlled element due to quail growing phase

Control Element	Quail Growing Phase (ages(days))		
	Brooding (1-7)	Premature (8-16)	Grower (17-21)
Temperature (oC)	35-37	33-35	30-32

Manuscript published on 30 September 2019

* Correspondence Author

Arman Hadi Azahar*, B. Eng. (Hons) (2011) and MSc (2015) in Mechatronic Engineering from Universiti Teknikal Malaysia Melaka.

Muhammad Azizi Ismail, B. Deg. In Electrical Engineering Technology (Industrial Automation & Robotics) with honours from Universiti Teknikal Malaysia Melaka.

Rozilawati binti Mohd Nor, Master of Science in Electrical Engineering on 2015 at Universiti Teknikal Malaysia

Mohamad Haniff Harun, Faculty of Electrical and Electronic Engineering Technology, Universiti Teknikal Malaysia Melaka.

Amar Faiz Zainal Abidin, B.Eng. (Hons) in Electrical and Electronics Engineering from University of Nottingham, Malaysia and M.Eng. from Universiti Teknologi Malaysia

© The Authors. Published by Blue Eyes Intelligence Engineering and Sciences Publication (BEIESP). This is an [open access](http://creativecommons.org/licenses/by-nc-nd/4.0/) article under the CC-BY-NC-ND license <http://creativecommons.org/licenses/by-nc-nd/4.0/>



Development of Automatic Poultry System (Quails) using Arduino Microcontroller

Control Element	Quail Growing Phase (ages(days))		
	Brooding (1-7)	Premature (8-16)	Grower (17-21)
Light Intensity (lux)	≤ 10	5-7	
Air Quality Index (ppm)	< 1000		

^a. Sample of a Table footnote. (Table footnote)

B. Developing Project System Operation

The sensors which is DHT11 temperature sensor, TSL2561 digital luminosity/lux sensor, and MQ135 air quality sensor is used for the purpose of interfacing between surround analog parameter with the microcontroller system in order to control the output which is ceramic heating bulb (heater), cooling fan, LED flood lamp, and ventilation fan. The block diagram shown in Figure 1 and Figure 2 respectively show the general structure of project part arrangement including the microcontroller unit, display unit, and input/output (I/O) unit and flow chart of project system. Microcontroller unit used in the project is Arduino UNO and it is attached together with the 20x4 Liquid Crystal Display (LCD) as the display unit as shown in the illustration in Figure 3.

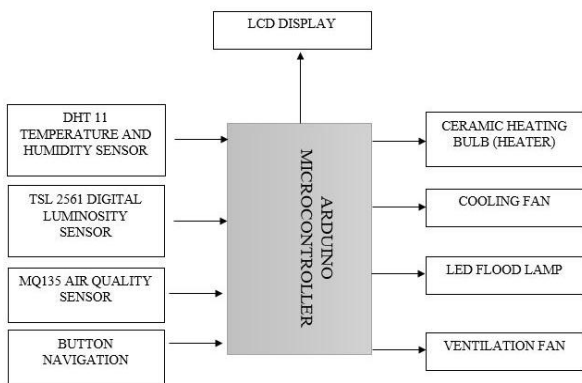

Fig. 1. Block diagram of Project IO declaration

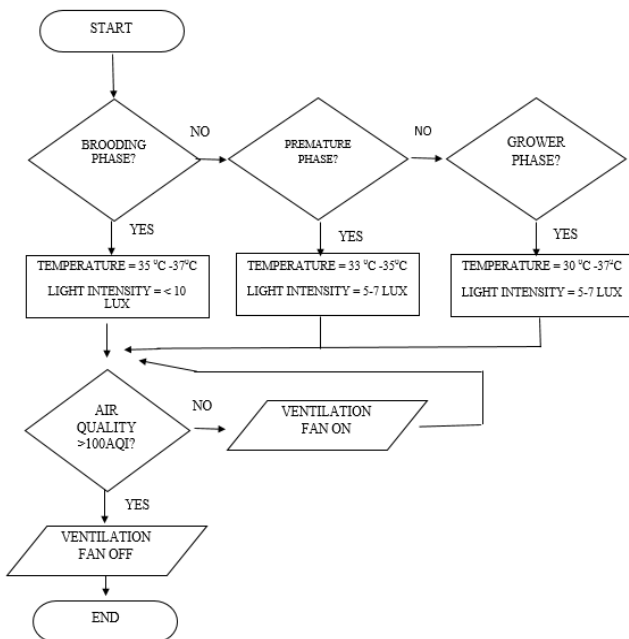

Fig. 2. Overall Project Operation Flowchart

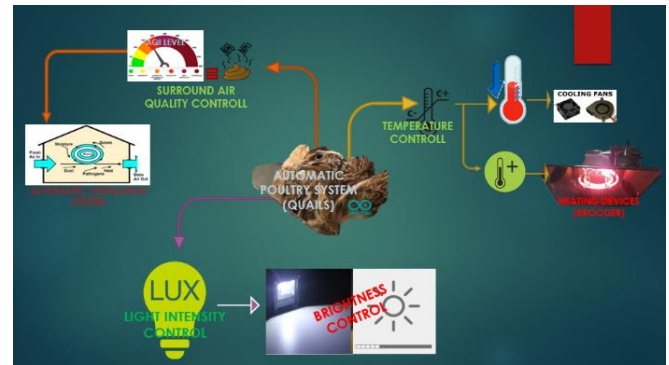

Fig. 3. Illustration of project Integration

C. Project Determination

This subtopic elaborates more about the development of mechanical design for closed house quail poultry system prototype and also electrical and electronic parts of the project. Figure 4 shows the idea of the project prototype design from SolidWork software while Table II shows the design explanation.

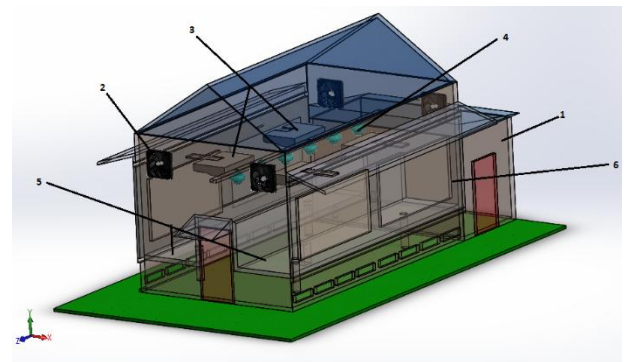

Fig. 4. Project prototype design.

Table- II: Design Explanation

Numbering on Figure 4	Explanation.
1	Control room
2	Ventilation fan
3	Electronic brooder (heater)
4	LED flood lamp
5	Quail growing region
6	Side wall curtain.

^a. Sample of a Table footnote. (Table footnote)

The project circuit were test and simulate in Proteus design suite software in order to see the operational of the circuit before the circuit were transfer into the real circuit which use strip board and several component module. Figure 8 shows the simulation circuit for this project.

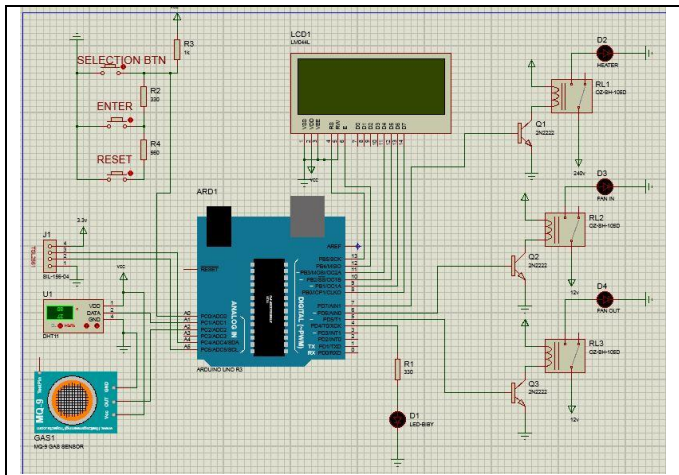

Fig. 5. Project simulation circuit

III. RESULT AND ANALYSIS

A. Analysis of Temperature Control System

The system has been set to control maintain the temperature at specific range based on the growing phases as stated in previous chapter as shown in Table III. The functionality of the system has been analyze before the project prototype undergo the real broiler quail poultry experiment to ensure the system operates correctly. After the testing, the project ready to undergo actual broiler quail poultry and during the period of the experiment, the surround temperature were recorded and tabulate in graph as shown in Figure 6.

Table- III: Temperature Control Element

No.	Growing phase loop selection	Varies Temperature (0C)	Output Element Status (On/Off)		Remarks
			Heater	Cooling Fan	
1	Brooding	33	On	Off	Correct
2		36	Off	Off	Correct
3		40	Off	On	Correct
4	Premature	39	Off	On	Correct
5		34	Off	Off	Correct
6		31	On	Off	Correct
7	Grower	26	On	Off	Correct
8		32	Off	Off	Correct
9		35	Off	On	Correct

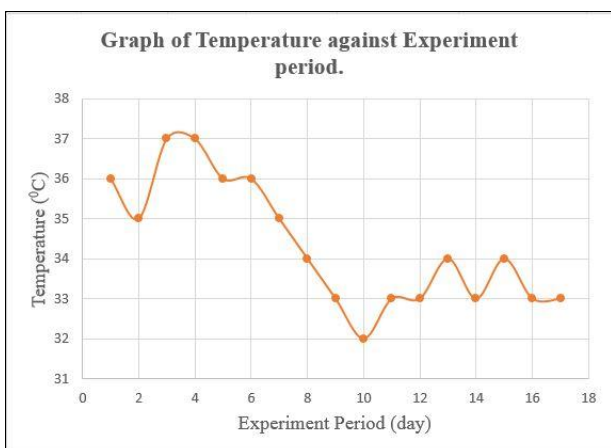

Fig. 6. Environment Temperature against Experiment

period.

B. Analysis of Light Intensity Control

The brightness of the flood lamp is being controlled by manipulating Pulse Width Modulation (PWM) value from 0-255. In order to control the light intensity (lux), the experiment was handled to analyze the relationship between varies PWM value and light intensity (lux) value measured by the TSL2561 Digital Luminosity Sensor. Figure 7 shows the experimental setup while Figure 8 shows the graph of relationship between PWM and lux.

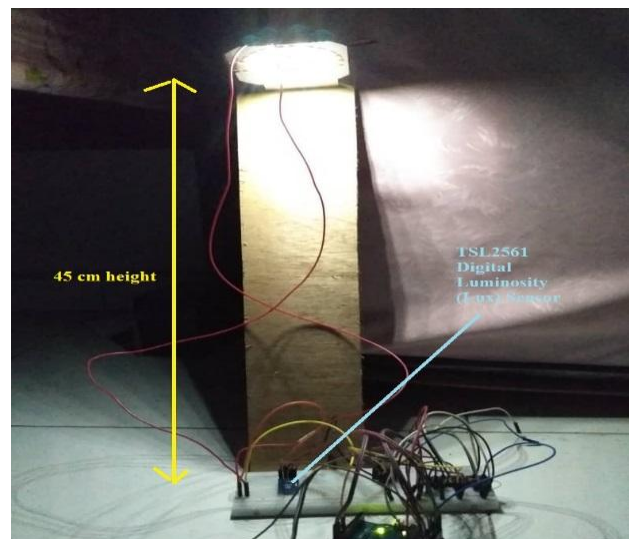

Fig. 7. PWM-LUX experiment setup

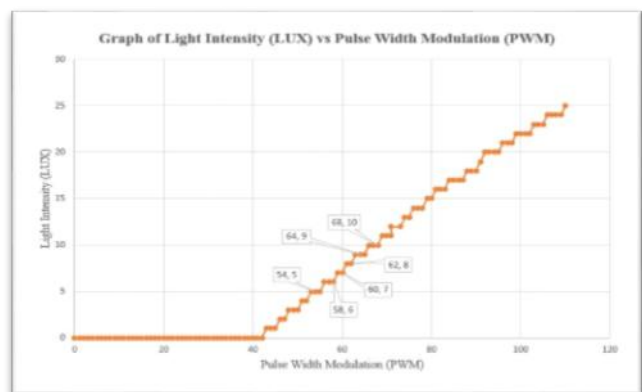

Fig. 8. Relationship between PWM and LUX

The amount of light intensity (lux) is being control based on the quail growing stages. Figure 9 shows recorded lux value during the project prototype undergo actual broiler quail poultry experiment.

Development of Automatic Poultry System (Quails) using Arduino Microcontroller

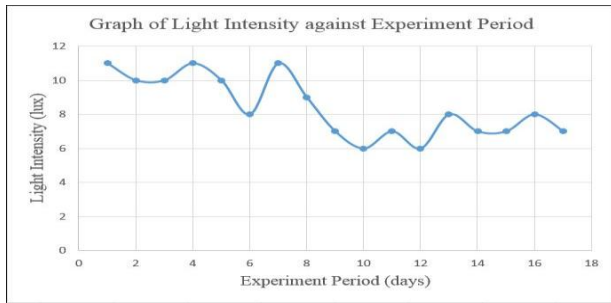

Fig. 9. Relationship between Growing Duration and LUX

C. Analysis of Air Quality Monitoring System

In the project system integration, the program code has been modified to control and trigger the ventilation system when the AQI value read by MQ135 Air Quality sensor indicate bad air quality (>1000ppm). Figure 10 shows the recorded AQI value and the operation of the ventilation system during the prototype has undergone actual broiler quail poultry.

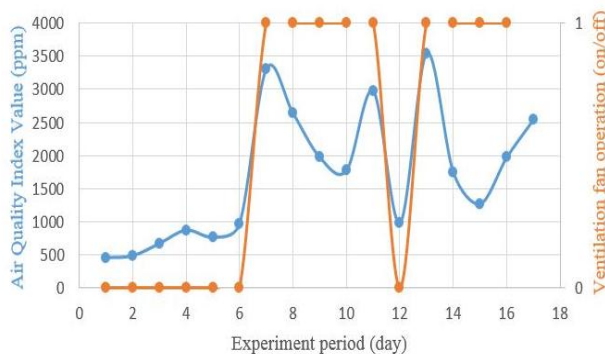

Fig. 10. Recorded AQI and Ventilation System Operation

D. Result of Actual Broiler Quail Poultry under Conventional method and Under Implementation of Project Prototype

The aim of this experiment being handle is to investigate the project success level and also to analyze the mortality, growth rate, and feed consumption of the quail under two different method of rearing which is firstly under traditional or conventional method and by implementing this project system. In both rearing method; the size of coop, number of quail chicks (flock), and type of feed given was set to be constant. Table IV shows the experiment setup for both rearing method.

Table IV: Experiment setup.

Method		Conventional method	Project system Implementation
Coop sized (L x W x H)		70cm x 57cm x 45cm	70cm x 57cm x 45cm
Number of quail chick(flock), N_T		24 pcs	24 pcs
Type of feed given base on growing phases	Brooding	Broiler Starter (Mash)	Broiler Starter (Mash)
	Pre-grower	Broiler finisher Pallets	Broiler finisher Pallets
	Grower	Broiler finisher Pallets	Broiler finisher Pallets

E. Analysis of Broiler Quail Performance under Conventional Rearing Method.

In conventional rearing method, some element such as temperature, light intensity, and air quality is not emphasis to specific level by means this rearing method depending on the local weather condition. All the related data which is feeding consumption, average bodyweight, and mortality was collected every day until the experiment is completed. When the experiment has been completed, the performance growth of quail which is mortality rate, daily Feed Consumption Ration (FCR), and body weight growth is being analyze to study the pattern and characteristic of them. Figure 11, Figure 12, and Figure 13 respectively shows the graph of daily Feeding Consumption Ration (FCR), average body weight, and the percent of mortality rate of the quail under conventional method of rearing.

Graph of Feed Consumption Ration (FCR) against Ages

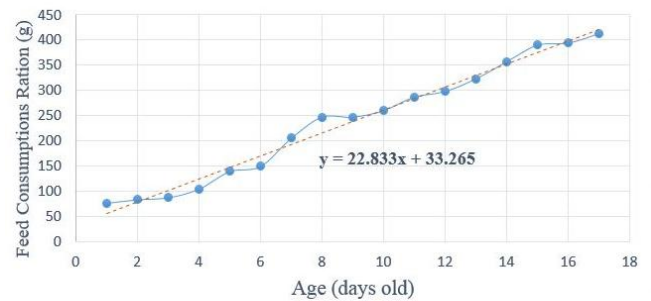

Fig. 11. Feed Consumption Ration against Quail's Ages.

Graph Of Average Body Weight against Ages

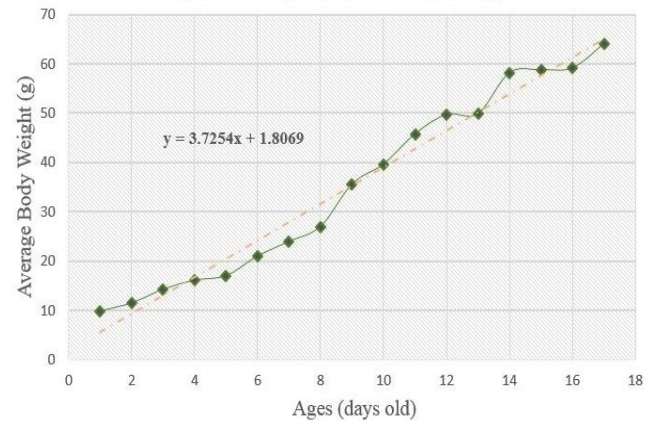

Fig. 12. Average bodyweight against Quail's Ages.

The mortality rate is calculated using (1).

$$MR_{\%} = N_{DOD} / N_T \quad (1)$$

where :

$MR_{\%}$ = Mortality rate

N_{DOD} = Number of quails died per day

N_T = Total number of the quails



Fig. 13. Quail’s mortality rates against ages

F. Analysis of Broiler Quail Performance under Project Prototype Implementation.

By implementing the project prototype in real broiler quail poultry situation, the surround coop climate parameter such as temperature, light intensity and air quality was set to be control at certain level/ value as stated in previous chapter. After complete the experiment period, performance of the broiler quail that has been rise/grow under project implementation which is Feed Consumption Ration (FCR), average body weight growth, and mortality has been analyze and at the same period of time the controlled parameter value were recorded to analyze the project functionality and efficiency. Figure 14, Figure 15, and Figure 16 respectively show the FCR, average bodyweight growth of the quail, and mortality rate with respective to the increasing in quail ages.

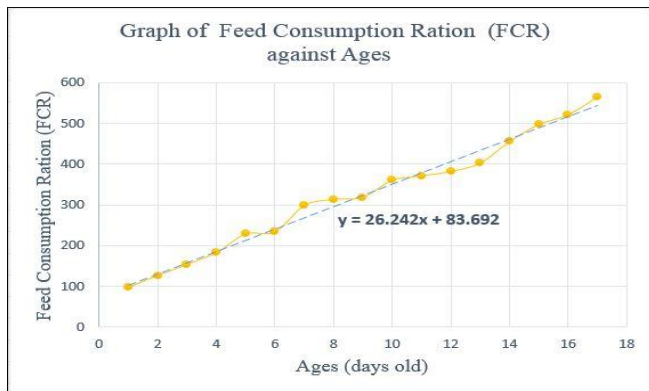

Fig. 14. Feed Consumption Ration against Ages.

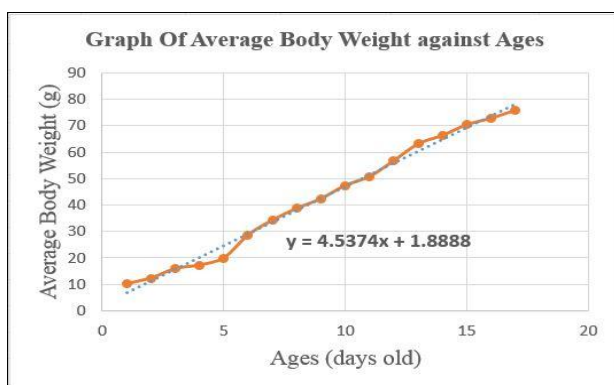

Fig. 15. Average bodyweight against ages



Fig. 16. Mortality rates against ages.

G. Analysis of Quail Growth Performance between Both Rearing Method

Based on the experiment data from two different Broiler Quail rearing method which is conventional method and project prototype implementation, all the related data that recorded which is mortality rate, average bodyweight growth, and Food Consumption Ration (FCR) is being compare to investigate whether by implementing the project prototype system, the performance of broiler quail can be improve or otherwise it same with the conventional method of rearing. According to the graph characteristics, the effective way to analyze the quail’s performance between these two rearing method is by comparing the gradient of the linear graph. Table V shows the performance comparison between two rearing method.

Table V: Performance Comparison of Broiler Quail Poultry between Conventional rearing Method and Project Prototype System Implementation.

Compared elements	Rearing Method.	
	Conventional	Project prototype implementation.
Mortality rates	5.26 %	4.35 %
Average bodyweight growth	3.7254	4.5374
Food Consumption Ration (FCR)	22.833	26.242

IV. CONCLUSIONS

The Automatic Poultry System (quails) using Arduino Microcontroller has operate successfully as desired plus it has succeed in increasing the performance of quail by reducing mortality rate in actual broiler quail poultry experiment to 4.35% from the conventional method of rearing mortality rate 5.26%. Therefore, the controlled element such as surround coop temperature, amount of light intensity (lux), air quality are proved the increasing performance of the quails livestock. At the same time, the average bodyweight shows the quality of the quails in term of quails growth rate.

ACKNOWLEDGMENT

First and foremost, I would like address my highest gratitude and appreciation to Faculty of Electrical and Electronic Engineering Technology, Universiti Teknikal Malaysia Melaka for support this research.



REFERENCES

1. Pn. Saonah Mohammad Noor , Dr, Hj Idris bin Abd. Kadir, D. D. A. A. bin J. (2010) Panduan Penternakan Puyuh.
2. Blake, J. P., Hess, J. B. and Berry, W. D. (2013) Early brooding temperature considerations for bobwhite quail, Journal of Applied Poultry Research. doi: 10.3382/japr.2012-00706.
3. Universiti, T. P. (2012) Taman Pertanian Universiti, Universiti Putra Malaysia.
4. Ben-Hamo, M. et al. (2010) Fasting triggers hypothermia, and ambient temperature modulates its depth in Japanese quail Coturnix japonica, Comparative Biochemistry and Physiology - A Molecular and Integrative Physiology. Elsevier Inc. doi: 10.1016/j.cbpa.2009.12.020.
5. Bonds, M. (2010) 'Quails (an Introduction)', p. 2010.

AUTHORS PROFILE



Arman Hadi Azahar received B. Eng. (Hons) (2011) and MSc (2015) in Mechatronic Engineering from Universiti Teknikal Malaysia Melaka. Currently, he is a lecturer at Faculty of Electrical and Electronic Engineering Technology, Universiti Teknikal Malaysia Melaka. His primary interests related to control system and Mechatronic Engineering.



Muhammad Azizi Ismail graduate in B. Deg. In Electrical Engineering Technology (Industrial Automation & Robotics) with honours from Universiti Teknikal Malaysia Melaka. Currently he is a Service Engineer at Trisystem Engineering Sdn. Bhd. His primary interests related to industrial automation, instrumentation system, High Integrity System protection for oil and gas industries.



Rozilawati binti Mohd Nor is born in Miri, Sarawak on 27th May 1988. She finished her first degree in Bachelor in Electrical Engineering (Control, Instrumentation & Automation) on 2011 then completed her Master of Science in Electrical Engineering on 2015 at Universiti Teknikal Malaysia Melaka. Now she is lecturer at Faculty of Electrical and Electronic Engineering Technology, Universiti Teknikal Malaysia Melaka. Her major field of study is in control system and most of her publications are in control system design and application. She is a member of Board of Engineers Malaysia (BEM) and Malaysian Board of Technologist (MBOT).



Mohamad Haniff Harun is a Senior Lecturer at Faculty of Electrical & Electronic Engineering Technology, Universiti Teknikal Malaysia Melaka (UTeM). His primary interests related to vision system



Amar Faiz Zainal Abidin received his first degree, B.Eng. (Hons) in Electrical and Electronics Engineering from University of Nottingham, Malaysia and M.Eng. from Universiti Teknologi Malaysia (UTM). He is currently attached as an academic staff with Universiti Teknikal Malaysia Melaka (UTeM). His research interests include electronic-based educational kits and nature-inspired optimisation algorithms.