

# Designing of an Efficient Electronic module for Sensory Network used in Smart City



Santosh Kumar Sahoo

**Abstract:** (Please read carefully abstract of the template). Now-a-days the world population is rapidly increases for which a dreadful requirement is necessary for developing a livable city. Hence the term Smart City is introduced which focus on the Smart environment and environment development, smart waste management and sanitation, smart water management and harvesting, smart energy management etc. In order to monitoring the entire city in a smart way, all the related information is required to collected in an efficient manner. Hence, the Sensory Network operated in wireless mode is a best choice for collecting useful information in several points of the cities. Though, the sensory Network operated in wireless mode consumes a high power so the sovereignty of the module. This paper projected a designing of an efficient electronic circuit module which operate with less power for sensory network used in a smart city. The proposed module consists of a sensory module along with storage unit. The Sensory module operates in wireless mode is implemented by multi-channel Radio Frequency (RF) with a frequency range of 310 to 910 MHz and an External Memory as Electrically Erasable Programmable Read Only Memory (E<sup>2</sup>PROM) with Real Time Clock Chip (RTC-DS1307IC) is considered as storage unit. Finally, the designed module is operated by considering both the information from sensory nodes and storage unit.

**Index Terms:** Livable, Smart waste management, Sensory Network, Electronic module, E<sup>2</sup>PROM

## I. INTRODUCTION

Depending on various factors a city is to be considered as smart city and the selecting criteria is varies from place to place or country to country. Therefore, the India Government has taken an optimistic step for formation of smart city task [1,2]. Under this scheme, a target of 100 smart cities to be developed in India by 2020. To maintain an ecological balance a proper planning is necessary for an unplanned area and open spaces, which is the manifesto of the smart city policy designed by the Government. The main objective of this scheme is to provide a better living environment through an updated technology [3,4]. The Smart Cities (SC) uses a key performance indicator for monitoring all the city process activity and provides a better sustainability [5,6,7]. This performance indicator is achieved by implementation of sensor nodes or networks at various corner of the city.

Depending on the operative condition, security, accuracy, environmental condition and the cost factors the best suitable plat form is selected as wireless mode of operation of sensory module. And this mode of sensor operation provides the wide operative range with high efficiency. A massive number of sensory elements, microcontroller, radio transceivers with data storing unit forms a Sensor network module. The data storing unit also comprises with microcontroller, wireless radio transceiver, storage unit and a RTC. A drawback associated with the sensory network operated in wireless mode is its turn-on time. As the operating time will be reduced with a system which consumes more power. Hence, to optimizing power consumption the duty cycle is managed by an internal timer or a separate wakeup radio triggered externally [8,9,10].

## II. EXPERIMENTAL MODULE DESCRIPTION

The physical parameters are sensed by the sensory ports and the detected information is sending to storing unit. The schematic block diagram for the proposed electronic module is presented in figure-1. An external power supply is feed to the micro controller and processor (PIC-16F88) operated with 5V and operating frequency of 1 MHz. The Sensing element relates to the processor for sending the information related to physical parameter to be monitored. A low power Real Time Clock is used for power backup automatically during the power failure. The microprocessor (PIC-16F88) is used here due to low power consumption (i.e. 3mW at operating mode and 0.189 nW at sleep mode with a frequency of 4MHz and output voltage of 2V). The lithium ion battery is considered as an external source with a nominal voltage of 3.75V and current capacity of 2600mAh. To continuous power supply the switching arrangement is used. For operating in wireless mode an external crystal oscillator of 4 MHz is connected along with a couple of 22 pF capacitors with respect to ground.

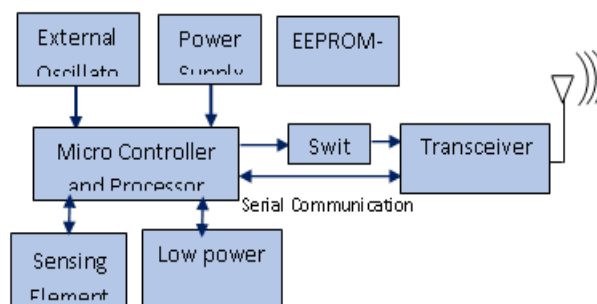

Fig.1. Proposed module

Manuscript published on 30 September 2019

\* Correspondence Author

Santosh Kumar Sahoo\*, Department of EIE, CVR College of Engineering, JNTUH Hyderabad, India,

© The Authors. Published by Blue Eyes Intelligence Engineering and Sciences Publication (BEIESP). This is an open access article under the CC-BY-NC-ND license <http://creativecommons.org/licenses/by-nc-nd/4.0/>

## Designing of an Efficient Electronic module for Sensory Network used in Smart City

By using the sensory unit and RTC unit the data corresponding to physical variable is acquired. A unit is a 3-pin socket is connected in between the sensor and microcontroller unit as per the figure-2(a).

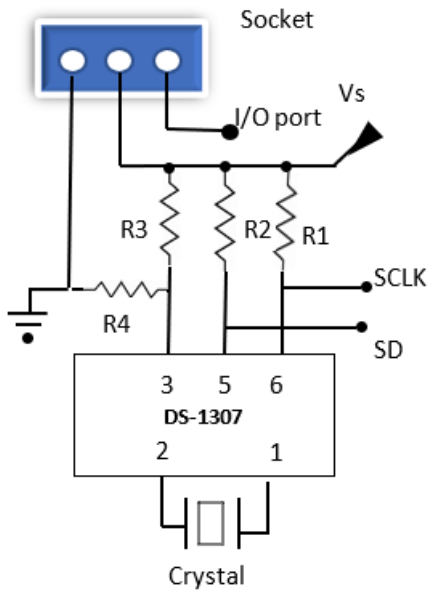

Fig. 2(a) sensing element circuit comprising with RTC

Real time along with date of measuring task is obtained by RTC unit. In the figure-2 (a) the System Data (SD) and System Clock (SCLK) is used to communicate with RTC-microcontroller.

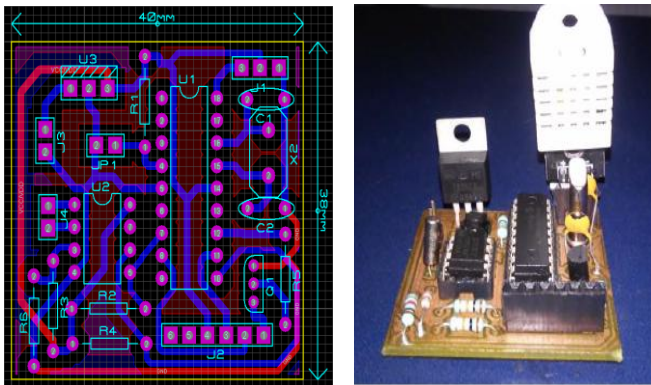

Fig. 2(b) PCB design with proto type model

The voltage divider circuit formed by resistors (R1 & R3) enables the switching operation for power supply depending upon the battery voltage. Interruption of sending data will be attained by configurable time periods (usually 1 to 6 minutes) and during this period the node will remain in sleep mode for saving energy. While information corresponding to physical variable is transmitted it contains the measuring value, ID of node along with date and time. Figure-2(b) represents the PCB Layout and the fabrication of prototype module. This module is employed as both transmitter and receiver purpose during the experiment. Sensor nodes are placed at various points of different environment. The selection of places was performed by considering the high sun radiation with respect to time.

## III. RESULT DISCUSSION

The proposed experiment was performed at CVR college of engineering college campus, Hyderabad. In this experiment two sensing element and one data receiver was used to implement as a networking module. The proposed wireless module is operated with 925 MHz frequency. Positioning distance between sensing unit and data receiver unit is maintained as 85 meters and the sensing module is mounted with a battery supply. Here two sensors are implemented for measuring temperature and humidity. The sensor (DHT-11) is used for measuring temperature and DHT-22 is used for measuring humidity (Relative Humidity).

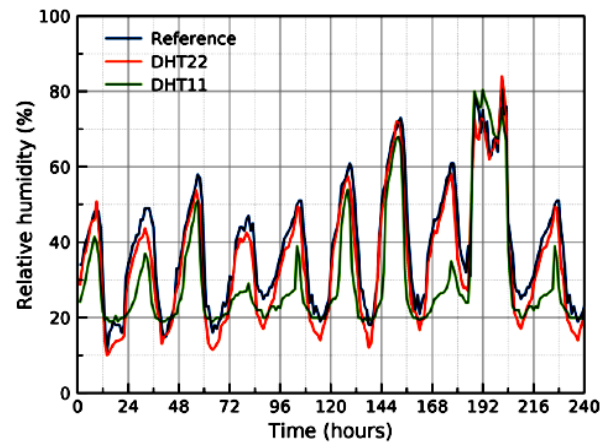

Fig.3. (a) Temperature measurement graph

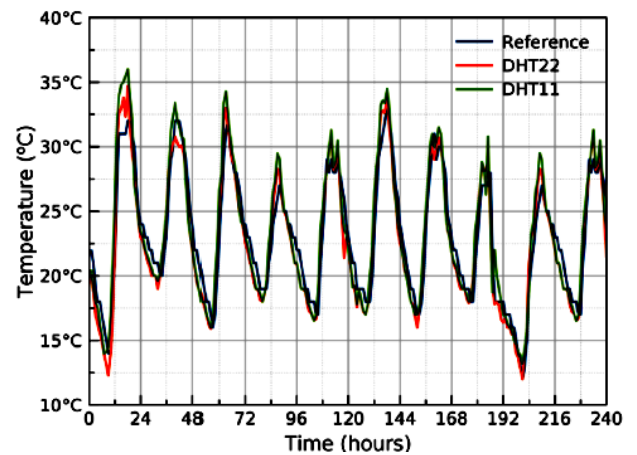

Fig. 3. (b) Relative humidity measurement graph

Fig.3 (a) and (b) represents the corresponding graph of temperature and relative humidity measurements. For both the measuring process a weather station device-pro-2 served as a reference data.

## IV. CONCLUSIONS

In this work, the operating condition of sensory unit in wireless mode is briefly explained and the presented module confirms the lowest power consumption capacity. The same unit also forecast a high connectivity range with high speed computational ability.

Individual sensory unit feed with the microcontroller and processor (PCI16F88) and the subsequent networking unit capture the data related to temperature and humidity over a long duration in an open environment.

The proposed unit also deliberates the development of a controller unit based on network connectivity to operate in dynamic environment. Considering the various issues related to smart city the presented model is a cost effective one.

## REFERENCES

1. Silva, B.N.; Khan, M.; Han, K. Towards sustainable smart cities: A review of trends, architectures, components, and open challenges in smart cities. *Sustain. Cities Soc.* **2018**, *38*, 697–713.
2. Alvear, O.; Calafate, C.T.; Cano, J.C.; Manzoni, P. Crowdsensing in Smart Cities: Overview, Platforms, and Environment Sensing Issues. *Sensors* **2018**, *18*, E460. doi:10.3390/s18020460.
3. Allam, Z.; Newman, P. Redefining the Smart City: Culture, Metabolism and Governance. *Smart Cities* **2018**, *1*, 4–25.
4. Talari, S.; Shafie-khah, M.; Siano, P.; Loia, V.; Tommasetti, A.; Catalão, J.P.S. A Review of Smart Cities Based on the Internet of Things Concept. *Energies* **2017**, *10*, 1–23.
5. Costa, D.G.; Collotta, M.; Pau, G.; Duran-Faundez, C. A Fuzzy-Based Approach for Sensing, Coding and Transmission Configuration of Visual Sensors in Smart City Applications. *Sensors* **2017**, *17*, 1–17.
6. Lin, J.; Yu, W.; Zhang, N.; Yang, X.; Zhang, H.; Zhao, W. A Survey on Internet of Things: Architecture, Enabling Technologies, Security and Privacy, and Applications. *IEEE Internet Things J.* **2017**, *4*, 1125–1142.
7. Zanella, A.; Bui, N.; Castellani, A.; Vangelista, L.; Zorzi, M. Internet of Things for Smart Cities. *IEEE Internet Things J.* **2014**, *1*, 22–32.
8. Costa, D.G.; Duran-Faundez, C.; Andrade, D.C.; Rocha-Junior, J.B.; Just Peixoto, J.P. Twitter Sensing: An Event-Based Approach for Wireless Sensor Networks Optimization Exploiting Social Media in Smart City Applications. *Sensors* **2018**, *18*, E1080, doi: 10.3390/s18041080.
9. Mota, V.F.; Silva, T.H.; Macedo, D.F.; Ghamri- Doudane, Y.; Nogueira, J.M. Towards scalable mobile crowdsensing through device-to-device communication. *J. Netw. Comput. Appl.* **2018**, *122*, 99–106.
10. Liu, J.; Shen, H.; Narman, H.S.; Chung, W.; Lin, Z. A Survey of Mobile Crowdsensing Techniques: A Critical Component for The Internet of Things. *ACM Trans. Cyber-Phys. Syst.* **2018**, *2*, 18:1–18:26.

## AUTHORS PROFILE



**Dr. Santosh Kumar Sahoo** working as Associate Professor in CVR College of Engineering, Hyderabad, Telangana State.