

# Interlinked Ac-Dc Microgrids by Fuzzy Based Tie-Converters for Autonomous Power Management



A. G. Tejaswini, M. RamasekharReddy

**Abstract** –Several operational drawbacks for interlinked AC-DC microgrids to the existing schemes of power management. Designed with main objective on based of their loading conditions power sharing among interlinked microgrids for some existing control schemes, while other schemes without considering specific loading conditions of the interlinked microgrids to regulate voltage. However, cannot reach the existing schemes both objectives successfully. To control these problems an autonomous power management for interlinked AC-DC microgrids by fuzzy based tie-converters is proposed. Fuzzy is the advanced controller that will be used in tie converters. By replacing PI with Fuzzy Logic Controller better results will be found. It makes fuzzy logic an effective tool for the conception and design of intelligent systems. The fuzzy logic toolbox is easy to master and convenient to use. The hybrid control has been proposed for the interlinking or tie-converters of the AC-DC microgrids for autonomous power management with FLC. The proposed is fully autonomous scheme ,while for tie-converters and generators it retains plug-n-play features. Under different operating scenarios the performance has been validated for the proposed control scheme with FLC. Better voltage regulation maintaining autonomously in the DC microgrid managing the power deficit effectively can be done through proposed scheme. To demonstrate its effectiveness ,the system is modelled and its performance will simulated on MATLAB.

**Index Terms** – Power management, autonomous control, interlinked microgrid, droop control, distributed control, hybrid control.

## I.INTRODUCTION

A microgrid is a group of interconnected distributed energy resources and loads that acts as a single controllable entity with in clearly defined electrical boundaries with respect to grid. The technical improvement in action of bringing resources into effective of alternative energy technologies and renewables plays an important role in power electronics [1]-[3] which have clearly understand in different forms of combinations and network topologies [4],[5]. While meeting load requirements their overall aim of network topology and control to make as possible the benefits predominantly determined. Alternative energy and renewable technologies are bring into effective action extensively.

These new technologies which are give effective action in the form of microgrid is tend to choose due to more superior, like increase reliable supply, best effective use of resources and advancement power quality [6]-[7].

At a recent time, more improved grid architectures including multi-microgrid [8]-[11], the zone based grid architectures [12], interlinked AC-DC microgrids [13]-[17] and interlinked AC-AC microgrids [18],[19] have become visible.

The main goal is to utilize more benefits from alternative energy and renewable resources of these improved network architectures. For example two or more interlinking microgrids, it will hold up frequency and voltage, flexibility of interlinked microgrids, make possible reserve sharing and finally overall reliability increase. The interconnecting between two or more microgrids arrangement or with beneficial grids depends on the overall goals mainly, and also used the management and control scheme in single microgrids. When different operating frequencies and/or voltages have two or more microgrids are mainly used the harmonizing tie-converters. The tie-converters are absolutely necessary if the microgrids have different overall control aim to be interconnected and power flow have to be regulated among them [18]. In similar way, tie-converters necessary for the interconnecting of DC microgrid with another AC microgrid or with beneficial grid to regulate power flow in other functionalities, and that has been discovered in the published literature under different kinds of situation [13]-[17]. In [13], for interlinking or tie-converters the demand-droop control scheme of AC-DC microgrids has been proposed. Interlinked droop controlled AC-DC microgrids on the bases of normalized terminal frequency and voltage the action of power flow decided. Relative loading based on their condition between two interlinked microgrids an autonomous power management is possible for this scheme. By connecting storage system to interlinked microgrids has been enlarged the same power sharing scheme [14]. This scheme been made better for interlinking converter to reduce the energy flow by developing gradually auto-tuning [15]. The existing auto-tuning make it possible for the power transfer only when one microgrid is lightly-loaded while other heavily-loaded. For different functional conditions for the interlinked AC-DC microgrids has been researched the power sharing on droop based scheme in [16]. In [17], presented a three-port system consist of DC, AC and a storage system for overall aim to power dealing. It is as presented in [15] that based on loading condition of interlinked microgrid for power sharing dealing is same.

**Revised Manuscript Received on 30 July 2019.**

\* Correspondence Author

A.G.Tejaswini\*, PG Research Scholar, Dept. of Electrical Engineering, JNTUA, Anantapur, AP, India

M.RamasekharReddy, Assistant Professor, Dept. of Electrical Engineering, JNTUA, Anantapur, AP, India

© The Authors. Published by Blue Eyes Intelligence Engineering and Sciences Publication (BEIESP). This is an [open access](https://creativecommons.org/licenses/by-nc-nd/4.0/) article under the CC-BY-NC-ND license <http://creativecommons.org/licenses/by-nc-nd/4.0/>

In [20], for interlinked AC-DC microgrid another power management scheme is used, it has an aim to regulate DC microgrid of voltage without any considering the generator of specific loading level. This scheme put into effect for only single-converter which the feature of plug-n-play limits. Based on relative loading condition the power sharing droop based schemes transfer power for interlinked microgrids. During uneven or contingency loading condition the power transfer does not regulate the frequency and/or voltage but supports frequency and voltage of the interlinked microgrids. Although these schemes allow for the interlinked microgrids plug-n-play feature. By using only PI controller it will get high starting overshoot and sluggish response to sudden disturbances. These drawbacks can be precisely addressed in this paper by using proposed control scheme. By using fuzzy controller steady state error can be reduced.

Fuzzy management has transpired as the foremost active and fruitful analysis area, due to lack of quantitative input and output data for conventional methods. Fuzzy logic controller supported fuzzy logic, gives a way to turn an expert knowledge-based linguistic management strategy into an automatic management strategy.

The proposed interlinked AC-DC microgrids by fuzzy based tie-converters for autonomous power management transfers power during peak-load demand from AC to DC microgrid, and generators specific loading conditions will also consider and can regulate DC microgrid of the voltage. The proposed scheme allows for tie-converter the plug-n-play feature and minimize the using of more converters in operation to keep away from unnecessary losses. During its eventuality condition and peak demand to the DC microgrid excess power to transfer and also consider the AC microgrid to have regulated frequency and voltage. The proposed control scheme with FLC to control the overall loading condition for DC microgrid of the droop-controlled depends on the information of terminal voltage for the tie-converter. Based on loading condition, during the eventuality condition or peak-load demand automatically starts tie-converter and the power will transfer to DC microgrid. With this hybrid control mode proposed scheme the voltage is regulated at defined nominal voltage of the DC microgrid. The proposed scheme can permit to interact with more than one tie-converter, but it is against to the existing scheme where at the same time all tie-converters operate without regard of the power transfer required, only activate once the following tie-converter when power capacity of the first converter has been soaked. The proposed scheme is completely autonomous with extent of features.

## II. CONTROL OF AC AND DC MICROGRIDS

The DC microgrid consist of dispatchable generators, non-dispatchable generator and loads, as shown in fig.1. Non-dispatchable generator is solar-PV generator and dispatched generators are fuel-cell, microgrids. Dispatched generators are source of electricity that can be used on demand. It can be turned ON or OFF, or can adjust their power output according to an order. Non-dispatched generators are not continuously available due to the weather condition. It does not rectify the load changes. Operate solar PV non-dispatchable system in current control mode and thus high

power will extract at all the times. The dispatched generators can be controlled by decentralized or centralized control scheme and are usually for resilient the renewable capacity. Due to reliable and simplicity, the decentralized droop scheme is more favour. Therefore, for dispatched generators the traditional group scheme is used, it is given by

$$\begin{aligned} V_{dc,ref,i} &= V_{dc,max} - \partial_{dc,i} P_{dc,i} \\ \partial_{dc,i} &= V_{dc,max} - V_{dc,min} / P_{dc,max,i} = \Delta V_{dc} / P_{dc,max,i} \end{aligned} \quad (1)$$

Where,  $V_{dc,ref,i}$  is  $i^{th}$  generator of reference voltage;  $i$  is the DC generator number ( $i = 1, 2, 3, \dots$ );  $P_{dc,i}$  is the  $i^{th}$  generator of output power;  $P_{dc,max,i}$  is the  $i^{th}$  generator of rated or maximum power;  $V_{dc,min} = V_{dc,norm,TC1}$  and  $V_{dc,max}$  are the defined minimum and maximum voltage;  $\partial_{dc,x}$  is the  $i^{th}$  generator of droop gain.

On the bases of (1), the voltage reference of generator 1 and 2 for the droop controlled can be calculated by (2) and (3). As DC bus voltage share generators 1 and 2 (i.e.,  $V_{dc,ref,1} = V_{dc,ref,2}$ ), (2) and (3) can be rewritten and equated by (4), which denotes that according to droop controlled generator of their rated power capacity will share proportional power.

$$V_{dc,ref,1} = V_{dc,max} - \partial_{dc,1} P_{dc,1} \quad (2)$$

$$V_{dc,ref,2} = V_{dc,max} - \partial_{dc,2} P_{dc,2} \quad (3)$$

$$\partial_{dc,1} P_{dc,1} = \partial_{dc,2} P_{dc,2} \rightarrow P_{dc,1} / P_{dc,max,1} = P_{dc,2} / P_{dc,max,2} = P_{dc,i} / P_{dc,max,i} \quad (4)$$

In (4) equality that the generator terminal voltages is same. Practically, due to which the generator terminal voltages are connected dissimilar lengths as they are not same through cable/feeders, precise sharing of power affect by mismatching the voltage at generator terminals, by using of any suitable compensation method it needs to be compensated.

The feeder voltage drop with compensation of droop equation can be rewritten by

$$V_{dc,ref,i} = V_{dc,max} - \partial_{dc,i} P_{dc,i} + i_{dc,i} X_i \quad (5)$$

The droop controlled DC microgrid of the voltage will change with varying the load, but within of defined allowed range. The voltage is set between 395V to 420V, for the droop controlled generators, the generators will deliver 100% power at 395V and there is no power at 420V. The tie-converters will start when in large amount of loaded the DC generators (e.g., 80% generators loading at less than or equal to 402.4V), to meet the peak load demand the tie-converters bring power from AC microgrid. For example of interlinked microgrids in fig.1, the DC microgrid of frequency and voltage is considered rigid. AC microgrid can be operate in grid-connected mode or secondary frequency and voltage regulation with droop controlled. In fig.1, the AC microgrid characteristics are shown where the frequency and voltage at nominal value are constant (e.g., 415V and 50 Hz). In more, to send excess power to the DC microgrid and to meet its local demand AC microgrid has adequate generation capacity which has been exhibit through the proposed control of autonomous tie-converters. It also the voltage of DC microgrid regulate.

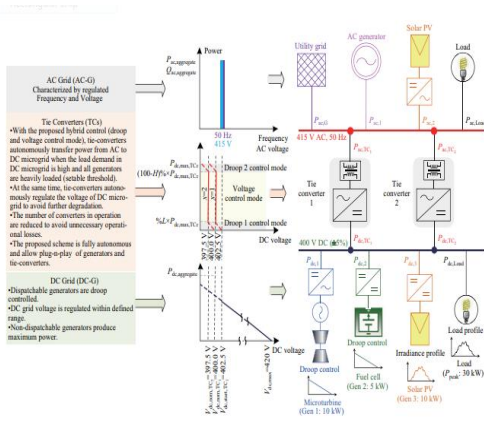

### III. PROPOSED HYBRID CONTROL OF TIE- CONVERTERS

The power rating for strong the renewable capacity of storage systems or dispatchable generators depends on changing of loads and the renewable source in the microgrid. The excessive changing of loads and renewables with a high power rating needs storage systems or dispatchable generators, which expressing possibility or not be a feasible solution. Alternatively, directly or through harmonizing converters, could be interconnected with insufficient generation capacity to another microgrid or usefulness grid. It is only able to be done through tie-converters for interlinking of DC microgrid with a AC microgrid. Dc microgrid is characterized with insufficient generation capacity due to excessive changing of the loads and renewable as a droop controlled system and AC microgrid is characterized with sufficient generation capacity as a frequency and voltage regulated system. By bringing the power from AC microgrid the power shortage in DC microgrid is controlled, during the less renewable power output or the peak load demand. Ideally, with the proposed tie-converter control it can be done autonomously and efficiently. Based on the following purposes the tie-converter of control scheme is developed : 1) To reduce the losses of power transfer, e.g., on based of power transfer demand the number of tie-converters should operate, and in the DC microgrid during peak-load demand only tie-converter should operate; 2) To achieve control of fully autonomous on the communication network without depending; 3) To transfer power during the peak load demand from the AC to DC microgrid or in the DC microgrid generation possibility; 4) To regulate the DC microgrid voltage of droop controlled; 5) To enable for generators and tie-converters the plug-n-play feature. Unlike in [13]-[17] for the interlinked AC-DC microgrid of existing schemes, voltage regulation mode control and a hybrid droop for tie-converters is proposed and the proposed control scheme of mathematical form is given by:

$$V_{dc,ref,TCx} = \begin{cases} \text{Off;} & V_{dc} > V_{dc,start,TCx} \\ V_{dc,start,TCx} - \delta_L,TCx \times P_{dc,TCx}; & 0 \leq P_{dc,TCx} \leq L\% \times P_{dc,max,TCx} \\ V_{dc,nom,TCx}; & L\% \times P_{dc,max,TCx} < P_{dc,TCx} < (100-H)\% \times P_{dc,max,TCx} \\ V_{dc,nom,TCx} - \delta_H,TCx [P_{dc,TCx} - (100-H)\% \times P_{dc,max,TCx}]; & (100-H)\% \times P_{dc,max,TCx} \leq P_{dc,TCx} \leq P_{dc,max,TCx} \end{cases}$$

Where  $TC_x$  entitled the tie-converter ( $x= 1,2,3,\dots$ );  $V_{dc,ref,TCx}$  is the  $x^{th}$  tie-converter of reference voltage ;  $V_{dc,nom,TCx}$  is the nominal voltage by  $x^{th}$  tie-converter to be regulated;  $V_{dc}$  is voltage of DC microgrid;  $V_{dc,nom,TC_{x+1}}$  is the DC microgrid voltage when maximum power transfers of  $x^{th}$  tie-converter;  $V_{dc,start,TCx}$  is the  $x^{th}$  tie-converter of threshold voltage to start;  $P_{dc,max,TCx}$  is the  $x^{th}$  tie-converter of maximum power limit;  $P_{dc,TCx}$  is the  $x^{th}$  tie-converter of DC power output;  $L\%$  and  $H\%$  are the allocated for droop 1 and 2 mode respectively rated power percentage of tie-converter;  $\delta_{H,TCx} = (V_{dc,nom,TCx} - V_{dc,nom,TC_{x+1}})/(H\% \times P_{dc,max,TCx})$  is the  $x^{th}$  tie-converter of droop 2 gain (at high power);  $\delta_{L,TCx} = (V_{dc,start,TCx} - V_{dc,nom,TCx})/(L\% \times P_{dc,max,TCx})$  is the  $x^{th}$  tie-converter of droop 1 gain (at low power). As shown in fig.1 ,when the DC microgrid voltage drops to the  $V_{dc,start,TCx}$  of threshold set tie-converter 1 starts in control mod of droop 1. This threshold voltage indicates that in the DC microgrid of all the generators are heavily-loaded (e.g. over 80% loaded).At the set condition to the voltage regulation mode a smooth transition enables in the droop control mode the start of the tie-converter i.e.,  $P_{dc,TCx} > L\% \times P_{dc,max,TCx}$ . During the voltage regulation mode, to meet the peak demand power of DC microgrid the tie-converter from Ac microgrid imports power and also its voltage regulate to the nominal value of  $V_{dc,nom,TCx}$  to be set. Furthermore,unlike all tie-converters of the parallel operation in the existing schemes, the operations of converters has been compute. The tie-converters only starts first when heavily-loaded in the DC microgrid of all the generators. Once the power capacity of first tie-converter near to saturation at  $P_{dc,TCx} = (100 - H)\% \times P_{dc,max,TCx}$ , from the voltage regulation to droop 2 control mode its control mode is changed to allow minor voltage drop. This minor voltage drop will enable its operation to start the next tie-converter which is caused by the droop 2 control mode. In case of the first tie-converter failure, automatically the second tie-converter starts its operation due to high load demand followed by the voltage drop. Therefore,the control strategy of proposed provides dynamic operation without compromising the inherited resilience during all operating conditions of the droop based scheme with fuzzy. Depending on  $L\%$  and  $H\%$  of chosen value the tie-converter's power will allocate for droop 1 and droop 2 control modes, and while considering the power and voltage measurement errors between different modes should be smooth transition tuned to allow in the considered microgrid. Fuzzy logic controller is used in the controller of a PI before sending the signal to the PWM module. It has been outstanding in dealing with complex, undefined, non-linear or time-varying systems. It is comparatively simple to execute because the control system usually does not need a mathematical model. Fuzzy logic has rapidly turned out to be a standout amongst the present best innovations for advanced control frameworks improvement. Quickly become one of today's most successful technologies for sophisticated control systems development.

It is a mathematical tool for managing vulnerability . With the voltage regulation mode of proposed scheme, the DC microgrid of voltage regulation overall performance can be amended. During the peak load demand in peculiar, at nominal value of DC microgrid voltage is regulated , which is not the case for interlinked microgrids with the existing power management. Different scenarios has been justify for load operating of proposed scheme, as explained in section IV.

IV.PERFORMANCE VALIDATION

For two different scenerios the proposed scheme of performance of DC microgrid has been validated.In first scenario,the microgrid contains a fuel cell, dispatched microturbine and variable load.

A non-dispatched solar PV generator is added for scenario 1, in the second scenario.In table I-III the system parameters are encapsulated.

The logic flow diagram of tie-converter is shown in fig.2. The two scenarios at different load operating conditions have been tested to establish capability and durability of the proposed scheme.

The fuzzy logic controller is replaced with PI. The control block diagram of tie-converter is shown in fig.3. FLC is an appealing selection when precise mathematical formulations are not doable. Different focal points of the FLC are, it can work with led exact information sources, it need not bother with quick processors

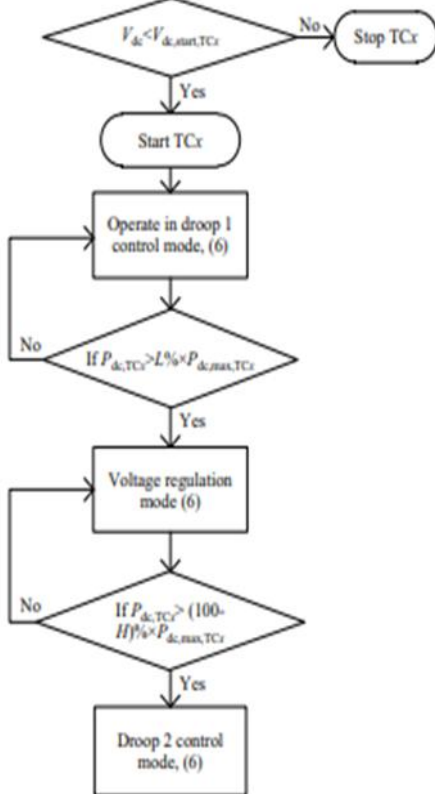

it is more strong than other non-linear controllers.

TABLE I CONTROL MODE OF DC AND AC MICROGRIDS

Entity	Control Mode
AC microgrid	Islanded-microgrid with regulated voltage and frequency Grid-connected mode
Tie-converter	Hybrid droop and voltage control mode
DC microgrid	Dispatchable generators Droop controlled Non-dispatchable generators Current control mode with MPPT

TABLE II DC MICROGRID PARAMETERS

Description	Parameter	Value
Voltage	$V_{dc}$ (V)	400 (+5%, -1.25%)
Micro-turbine	$P_{dc,max,1}$ (kW)	10
	$\partial_{dc,1}$ (V/kW)	2.5
Fuel cell	$P_{dc,max,2}$ (kW)	5
	$\partial_{dc,2}$ (V/kW)	5
Solar PV	$P_{dc,max,3}$ (kW)	10
Load	$P_{Load,peak}$ (kW)	25

TABLE III AC MICROGRID AND TIE CONVERTER PARAMETERS

Description	Parameter	Value
AC microgrid	$V_{ac}$ (V)	415 (l - l)
	f (Hz)	50
	$P_{dc,max,TC1}$ (kW)	10
	$V_{dc,start,TC1}$ (V)	402.5
	$V_{dc,nom,TC1}$ (V)	400.0
	$V_{dc,nom,TC2}$ (V)	397.5
	L% = H%	10%

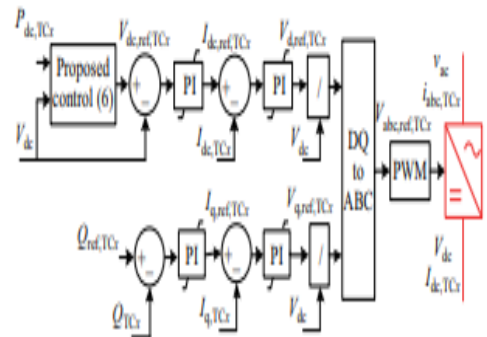

Fig.3. Control block diagram of tie-converter.

A.Scenario 1: DC Microgrid with microturbine, fuel cell and variable load

The DC microgrid contains fuel cell (Pdc,max,2 = 5 kW) microturbine (Pdc,max,1 =10 kW), and variable DC load (PLoad,peak = 20 kW) and through a tie-converter (Pdc,max,TC1= 10 kW) with AC microgrid these are interlinked, as shown in fig. 3.

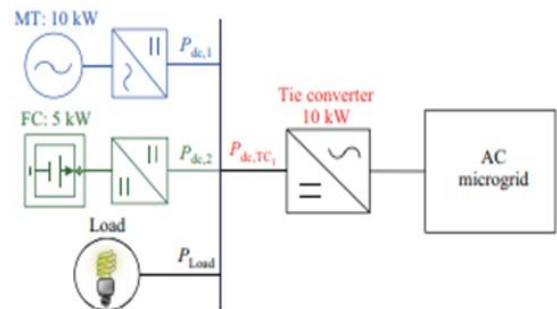

Fig. 3. Scenario 1: DC microgrid with microturbine, fuel cell and load

The DC microgrid load from 5 KW to 20 KW is vary in steps. At load demand of 15 KW , the generator 1 and generator 2 of expected loadings are more than 80%, and the DC microgrid voltage is below the  $V_{dc,start,TC1} = 402.5$  V set threshold . This condition will permits the tie-converter 1 from AC microgrid to import power and at the defined nominal value of  $V_{dc,nom,TC1} = 400.0$  V the DC microgrid voltage regulate. These performance results are shown in Fig.5. When load changes from 10 KW to 15 KW the DC microgrid voltage decreases below 400 V. Tie-converter 1 to start in droop 1 control mode when this voltage drop triggers. When the tie-converter control mode is start in droop 1 control mode at the set threshold ( $P_{dc,TC1} > 10\% \times P_{dc,max,TC1}$  ) the voltage regulation mode changeover immediately and satisfy the condition. At 1.2s, from 15KW to 20KW the DC microgrid load is further raised, and from the AC microgrid the power transferred is increased. From 8s to 12s in the DC microgrid all over the peak-load demand, tie-converter operate and regulate the DC microgrid voltage. At 16s the load demand is reduced in DC microgrid and automatically tie-converter turns off with a short delay. Therefore the proposed control scheme with fuzzy logic controller has good performance of voltage regulation and establish efficient operation.

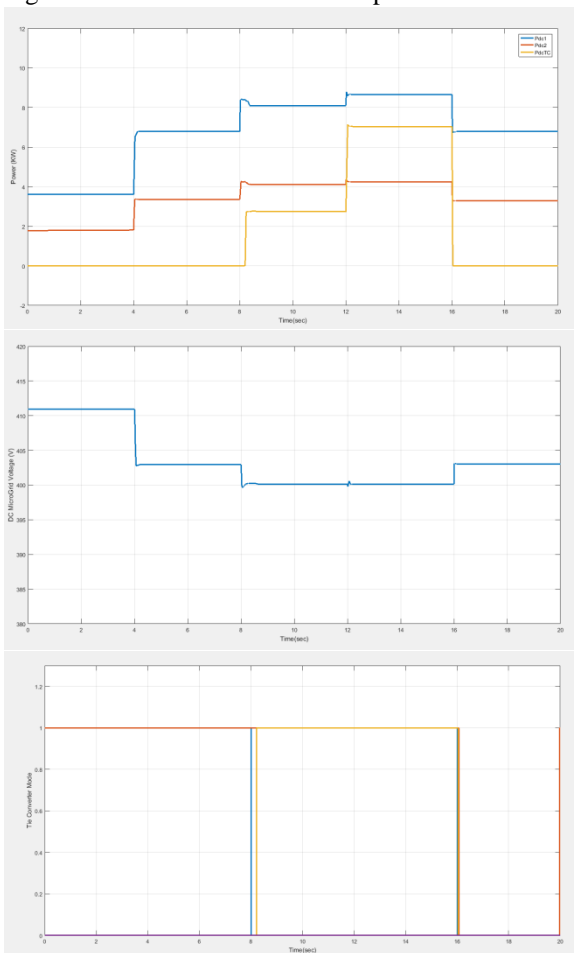
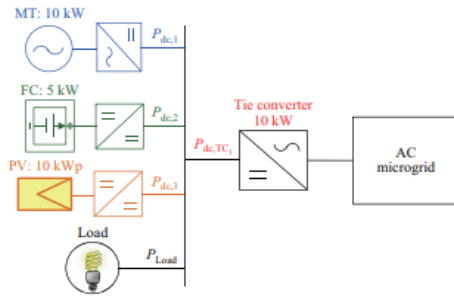

Fig.5. Results showing (a) tie-converter and generators power, (b) DC microgrid voltage and (c) tie-converter control signals for four different load operating conditions.

**B. scenario 2: DC Microgrid with Non-dispatchable Generator and Load profile**

To scenario 1 solar PV system of a non-dispatchable generator is added, which is shown in fig.6. For proposed strategy effectiveness with renewable generator and load demand different operating conditions are developed further.



**Fig.6. Scenario 2: DC microgrid with microturbine, fuel cell, solar PV and load**

The peak value 24.5KW is increases the DC microgrid load and then decreases, which is shown in fig.7. When loads of generators 1 and 2 increases 80% and DC microgrid voltage drops below to threshold set of  $V_{dc,start,TC1} = 402.5$  V. The solar PV output is lower with high of load demand. In voltage regulation mode the tie-converter operate from 8.5s to 14.2s. The DC microgrid load decreases when the output power of tie-converter is below  $10\% \times P_{dc,max,TC1}$  . This condition requires before turns off the tie-converter in droop 1 control mode operate.

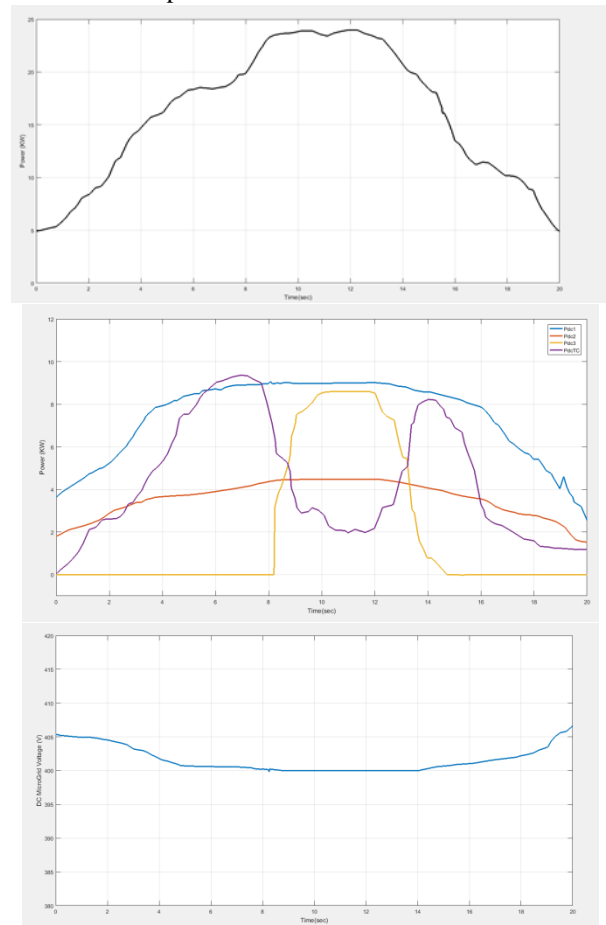

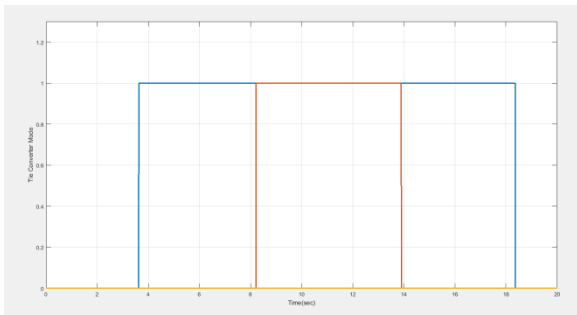

Fig.7. Scenario 2: Results showing (a) load demand of DC microgrid, (b) tie-converter and generators power, (c) DC microgrid voltage and (d) Tie-converter control signals at varying solar PV and load operating conditions.

## V. CONCLUSIONS

For interlinked AC-DC microgrids have an autonomous power management scheme with different configurations has been presented. The proposed scheme with fuzzy logic controller manages the shortage of DC microgrid power autonomously and efficiently. To avoid unnecessary operational losses using the number of tie-converters has been reduced in operation. For better regulation of voltage in the DC microgrid the scheme has established. For two different scenarios the durability and performance has been validated at variable load conditions in the DC microgrid of proposed scheme with FLC.

## REFERENCES

1. J. Rocabert, A. Luna, F. Blaabjerg, and P. Rodríguez, "Control of power converters in AC microgrids," *IEEE Transactions on Power Electronics*, vol. 27, no. 11, pp. 4734–4749, Nov. 2012.
2. M. Liserre, T. Sauter, and J. Y. Hung, "Future energy systems: integrating renewable energy sources into the smart power grid through industrial electronics," *IEEE Industrial Electronics Magazine*, vol. 4, no. 1, pp. 18–37, Mar. 2010.
3. M. Tsili and S. Papathanassiou, "A review of grid code technical requirements for wind farms," *IET Renewable Power Generation*, vol. 3, no. 3, pp. 308–332, Sep. 2009.
4. T. Strasser, F. Andren, J. Kathan, C. Cecati, C. Buccella, P. Siano, P. Leitao, G. Zhabelova, V. Vyatkin, P. Vrba, and V. Marik, "A review of architectures and concepts for intelligence in future electric energy systems," *IEEE Transactions on Industrial Electronics*, vol. 62, no. 4, pp. 2424–2438, Apr. 2015.
5. A. Kwasinski, "Quantitative evaluation of dc microgrids availability Effects of system architecture and converter topology design choices," *IEEE Transactions on Power Electronics*, vol. 26, no. 3, pp. 835–851, Mar. 2011.
6. N. Hatziaargyriou, H. Asano, R. Iravani, and C. Marnay, "Microgrids," *IEEE Power and Energy Magazine*, vol. 5, no. 4, pp. 78–94, Jul./Aug. 2007.
7. L. E. Zubieta, "Are microgrids the future of energy?: DC microgrids from concept to demonstration to deployment," *IEEE Electrification Magazine*, vol. 4, no. 2, pp. 37–44, Jun. 2016.
8. N. Nikmehr, S. N. Ravadanegh, "Optimal power dispatch of multimicrogrids at future smart distribution grids," *IEEE Transactions on Smart Grid*, vol. 6, no. 4, pp. 1648–1657, Jul. 2015.
9. H. Farzin, M. Fotuhi-Firuzabad, M. Moeini-Aghtaie, "Enhancing power system resilience through hierarchical outage management in multimicrogrids," *IEEE Transactions on Smart Grid*, vol. 7, no. 6, pp. 2869–2879, Nov. 2016.
10. J. Wu, X. H. Guan, "Coordinated multi-microgrids optimal control algorithm for smart distribution management system," *IEEE Transactions on Smart Grid*, vol. 4, no. 4, pp. 2174–2181, Dec. 2013.
11. W. Yuan, J. H. Wang, F. Qiu, C. Chen, C. Q. Kang, and B. Zeng, "Robust optimization-based resilient distribution network planning

12. against natural disasters," *IEEE Transactions on Smart Grid*, vol. 7, no. 6, pp. 2817–2826, Nov. 2016.
13. N. Hatziaargyriou, "Operation of multi-microgrids," in *Microgrids: Architectures and Control*, Wiley-IEEE Press, 2014.
14. P. C. Loh, D. Li, Y. K. Chai, and F. Blaabjerg, "Autonomous operation of hybrid microgrid with AC and DC subgrids," *IEEE Transactions on Power Electronics*, vol. 28, no. 5, pp. 2214–2223, May 2013.
15. P. C. Loh, D. Li, Y. K. Chai, and F. Blaabjerg, "Autonomous control of interlinking converter with energy storage in hybrid AC/DC microgrid," *IEEE Transactions on Industry Applications*, vol. 49, no. 3, pp. 1374–1382, May-Jun. 2013.
16. P. C. Loh, D. Li, Y. K. Chai, and F. Blaabjerg, "Autonomous operation of ac-dc microgrids with minimised interlinking energy flow," *IET Power Electronics*, vol. 6, no. 8, pp. 1650–1657, Sep. 2013.
17. N. Eghtedarpour and E. Farjah, "Power control and management in a hybrid AC/DC microgrid," *IEEE Transactions on Smart Grid*, vol. 5, no. 3, pp. 1494–1505, May 2014.
18. P. Wang, C. Jin, D. X. Zhu, Y. Tang, P. C. Loh, and F. H. Choo, "Distributed control for autonomous operation of a three-Port AC/DC/DC hybrid microgrid," *IEEE Transactions on Industrial Electronics*, vol. 62, no. 2, pp. 1279–1290, Feb. 2015.
19. I. U. Nutkani, P. C. Loh, and F. Blaabjerg, "Distributed operation of interlinked AC microgrids with dynamic active and reactive power tuning," *IEEE Transactions on Industry Applications*, vol. 49, no. 5, pp. 2188–2196, Sep./Oct. 2013.
20. I. U. Nutkani, P. C. Loh, and F. Blaabjerg, "Power flow control of interlinked AC microgrids," *IET Power Electronics*, vol. 6, no. 7, pp. 1329–1338, Aug. 2013.
21. X. Liu, P. Wang, and P. C. Loh, "A hybrid AC/DC microgrid and its coordination control," *IEEE Transactions on Smart Grid*, vol. 2, no. 2, pp. 278–286, Jun. 2011.

## AUTHOR PROFILE



**Araveti Ganga Tejaswini** completed a BTECH in electrical engineering from the INTELL Engineering College of JNTU Anantapur in 2016, and MTECH in electrical power systems from the JNTUA, Anantapur, AP, INDIA



**M. Ramasekhara Reddy** is the Assistant Professor in electrical engineering from the JNTUA, Anantapur, AP, INDIA