



MATLAB /Simulink Modelings and Experimental Design of Variable Frequency Drive for Speed Control of Three-Phase Induction Motor

Ghulam Akbar, Mahnoor Mughal, S.S.H. Bukhari

Abstract: This paper presents the PWM (Pulse Width Modulation) based speed control of three-phase asynchronous (Induction) motor. Induction motor is the leading machine used in many industrial controls, automation processes and in the field of HVAC applications. However, induction motor has fixed rated speed when directly connected to ac supply. It is necessary to design a drive system to obtain variable speed at its output to fulfill the application requirement. For this reason, we have designed a “VFD (Variable Frequency Drive)”, which gives desired speed- according to load changes unlike the DC motors, which do not require any speed controlling drive. Currently with the technological elevation in drive systems, the speed control of induction motor is more economical, convenient, reliable, and accurate. It provides continuous process control over a wide range of speed. VFD not only controls the speed of induction motor but also make its starting smooth by reducing starting inrush current and improves power factor. In result, power consumption is also reduced. In this paper, we have designed and analyzed the MATLAB/Simulink model of open loop drive system and then implemented an experimental hardware design.

Index Terms: Induction motor, VFD, SPWM

I. INTRODUCTION:

Variable frequency drive is a system designed to control Speed of three-phase AC Induction motor, which cannot be changed directly. In this project we aim to design a variable frequency drive, in which the (constant voltage to frequency ratio) V/F speed control method is used [1]. For variable speed PWM technique is used. The relationship of speed and supplied frequency are given in equation (1), which verifies that as the frequency changes it gives direct impact on the speed of induction motor [2].

$$n = \frac{120f}{p} \tag{1}$$

Where,

n= mechanical speed of induction motor

f= electrical frequency

p= number of stator poles

From the above equation, we can vary the electrical frequency in order to vary speed of Induction motor. It can be done using an open loop [3]. Furthermore, to achieve the more accurate desired speed, a feedback loop can be added which is done by designing a PI (Proportional Integral) controller. Nonetheless, till now we have worked on an open loop system of VFD. As induction motor draws high starting current so the power consumption is very high at this time. But VFD made it possible to reduce the power consumption by managing to reduce its starting current. Hence, VFD is an energy efficient system to control the induction motor in several industrial processes.

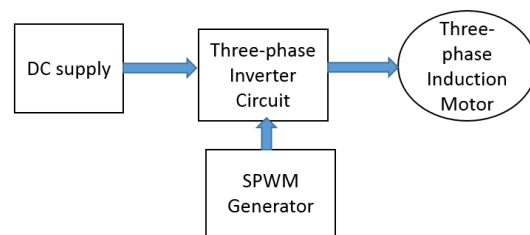

Figure 1: Open loop system of VFD

Figure.1 shows the complete VFD system, DC supply is given to three-phase inverter, which converts it into AC. Gate driver circuitry along with microcontroller generates the gate pulses to MOSFETs present in three-phase inverter. In result, we get variable frequency and variable voltage at output to feed an induction motor after filtering it. Hence, variable speed is achieved at output of induction motor.

Revised Manuscript Received on 30 July 2019.

* Correspondence Author

Ghulam Akbar*, faculty of Electrical (Power) Engineering at Sukkur IBA University, Sindh Pakistan

Mahnoor Mughal, faculty of Electrical (Power) Engineering at Sukkur IBA University, Sindh Pakistan.

Syed Sabir Hussain, Assistant Professor in the department of Electrical Engineering at Sukkur Institute of Business Administration.

Shah Bukhari, Department of Electrical Engineering SUKKUR IBA University, Sindh Pakistan.

© The Authors. Published by Blue Eyes Intelligence Engineering and Sciences Publication (BEIESP). This is an open access article under the CC-BY-NC-ND license <http://creativecommons.org/licenses/by-nc-nd/4.0/>

II. MATLAB/SIMULINK MODEL OF VFD SYSTEM WITH SOFTWARE RESULTS:

For the purpose of prototyping VFD, we have modelled it in MATLAB/Simulink. Firstly, a PWM based three-phase; three-level inverter is designed as shown in figure.2.

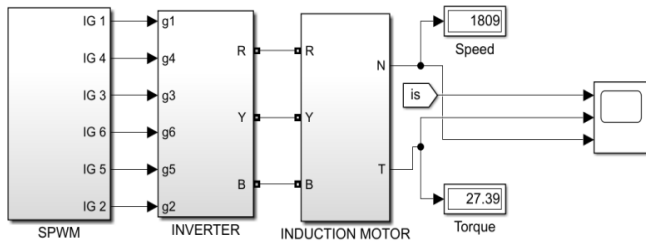

Figure 2. Complete MATLAB/Simulink model of VFD

a) Proposed Model of Sinusoidal PWM generator:

The subsystem block of proposed SPWM generator is shown in figure 3. The three sine waves of 50Hz, 120° electrically apart shown in figure.4, are compared with a high frequency carrier wave to produce gate pulses shown in figure 5(a) & 5(b).

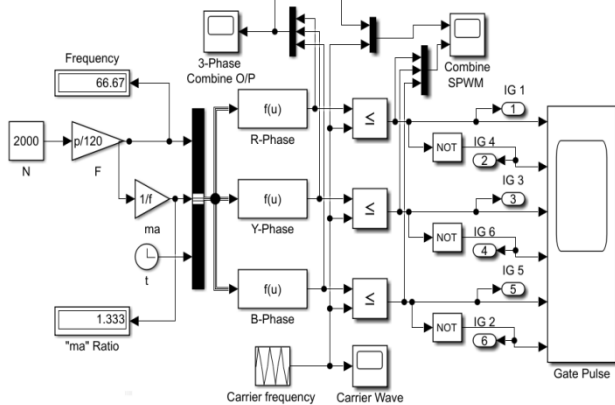

Figure 3. MATLAB/Simulink model of SPWM generator

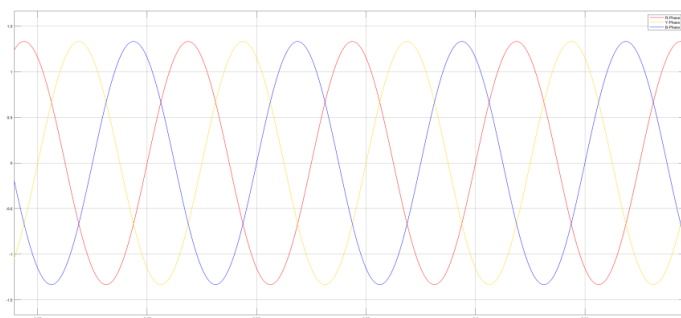

Figure 4. Three-phase reference sine waves

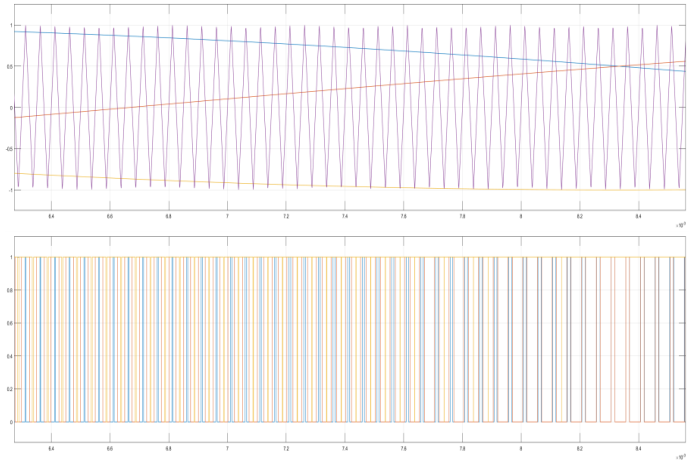

Figure 5(a). Sine and carrier wave comparison

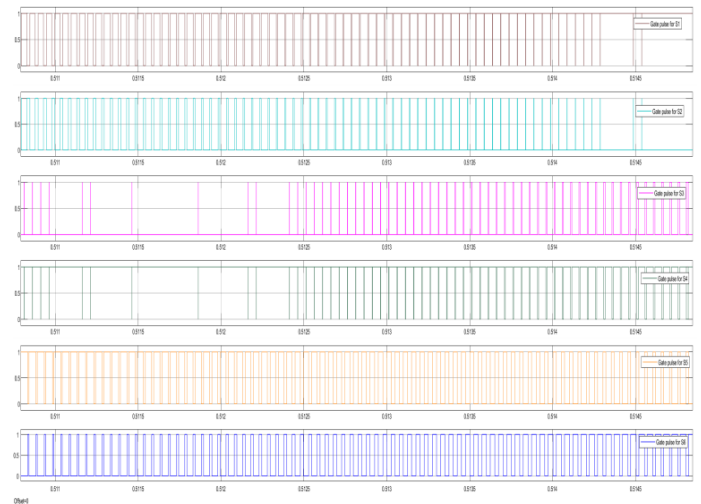

Figure 5(b). Gate pulses generated by SPWM generator

b) Three-phase three-level inverter :

The second block is three-phase three-level inverter circuit implemented in MATLAB/Simulink as shown in figure 7.

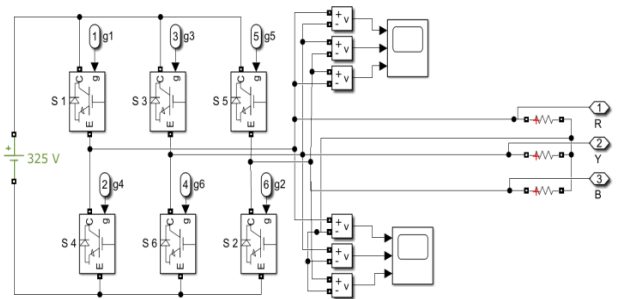

Figure 6. Three-phase three-level Inverter circuit

In this model, we have used six IGBT switches, which are connected in three-phase three-level bridge configuration. 325Volts DC supply is fed to this inverter. The gate pulses generated by SPWM generator is given to gate terminals of IGBTs. In result, three-phase voltages shown in figure.8 & 9, are generated at the output of inverter with constant v/f ratio.

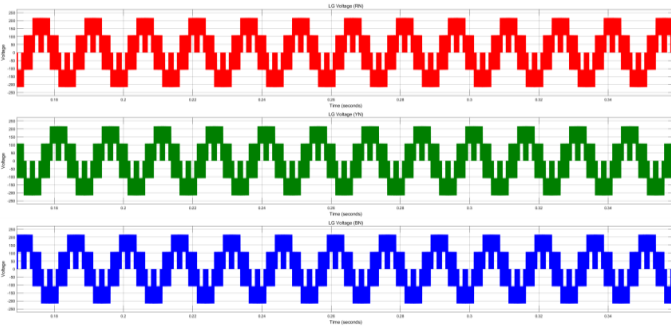

Figure 8. Output Line to Neutral Voltages of inverter circuit

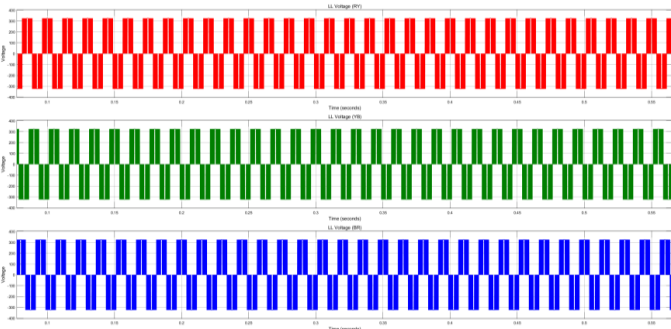

Figure 9. Three-phase output Line to Line Voltages of inverter circuit

c) Three-phase Induction motor model :

Then finally, the output of three-phase inverter is supplied to three-phase induction motor model in figure.9 with rating in Table.1. Afterwards the torque, speed and stator currents are analyzed shown in figure. 10. The rated speed of induction is 1350 rpm whereas, the results are taken for 2000rpm speed using SPWM technique.

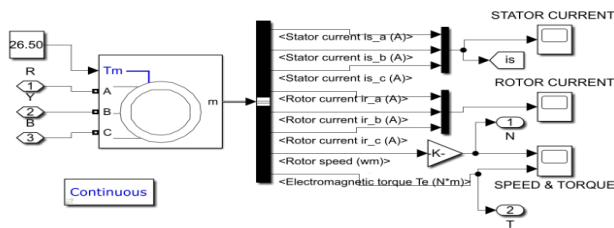

Figure 9: MATLAB/Simulink model of three-phase Induction

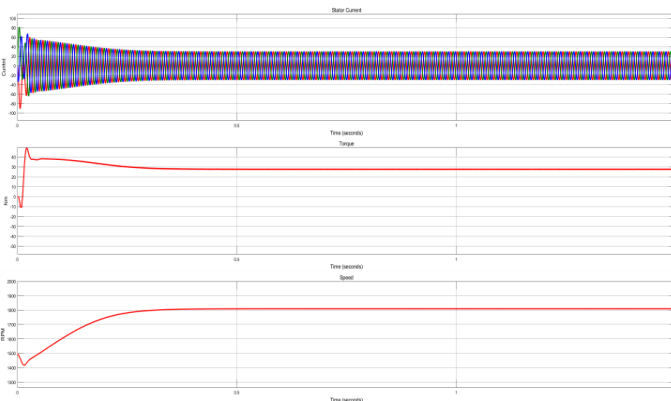

Figure 9: Stator current, Torque and Speed of induction motor

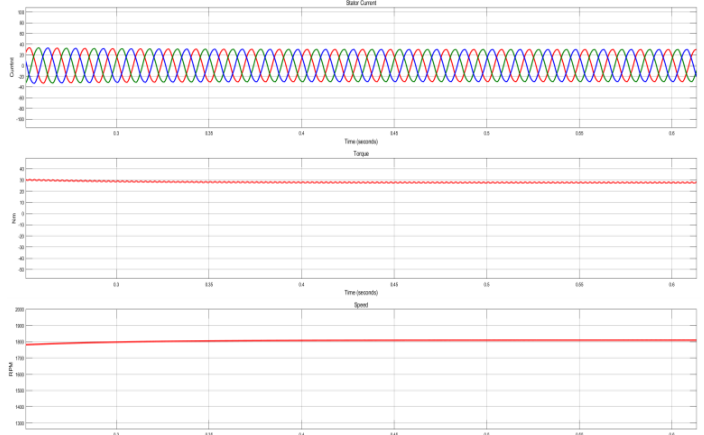

Figure 10: Zoomed in Stator current, Torque and Speed of induction motor

In this model, the rated speed of three-phase induction motor is 1350rpm. By using the proposed model of VDF, we have changed its speed as 1800rpm for verification.

III. VFD HARDWARE DESIGN AND RESULTS:

In hardware design of variable frequency drive, a 12V battery gives supply to single- phase switch mode inverter, which converts 12V DC into single-phase 220V AC. This 220V AC is given to bridge rectifier IC. The bridge rectifier IC converts 220V AC into 325V DC, which is filtered out by a capacitor. This filtered DC is given to three-phase inverter circuit.

Now, three-phase inverter gives a variable frequency and variable voltage at its output. Finally, this variable frequency, variable voltage output is given to three-phase induction motor whose speed is variable at the end achieved.

a) SPWM pulses generated using Microcontroller ATMEGA328P

The SPWM pulses are generated in figure.11 using ATMEGA328P microcontroller along with the gate driver circuit designed in figure. 14.

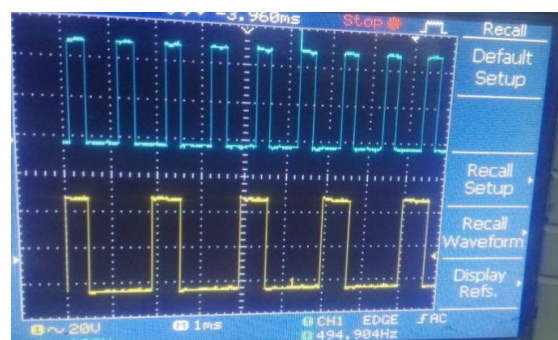

Following is the PCB design of three-phase inverter circuit along with its components 11N90 Power MOSFETs, GBU806 Bridge Rectifier ICs and capacitors and Fuses shown in figure 15, 16 & 17.

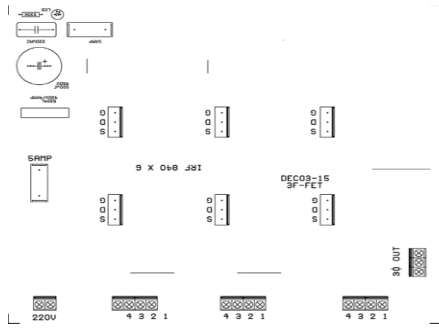

Figure 15: PCB design of three-phase inverter circuit with all components

Following is the PCB layout of three-phase inverter circuit:

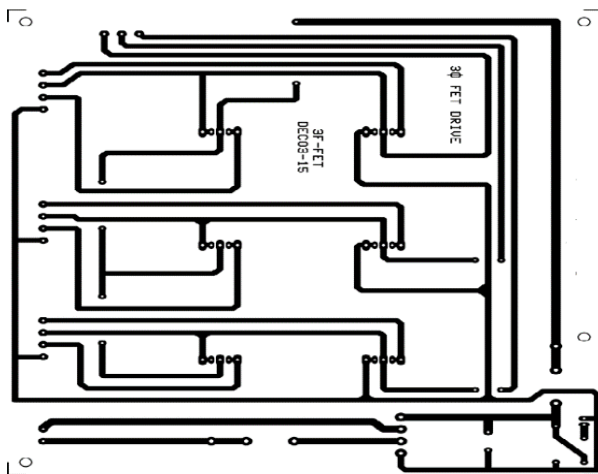

Figure 16: PCB layout of three-phase inverter circuit

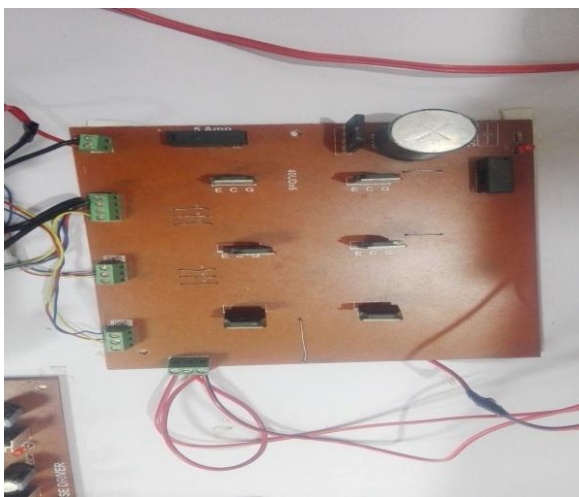

Figure 17: PCB of three-phase Inverter

Hence, hardware design is ready to operate. VFD using the PWM technique now controls the speed of three-phase induction motor.

c) Hardware Results

First, the induction motor is operated without VFD. Three-phase 220V ac is supplied from three-phase ac power supply shown in figure. 18. It shows the current of induction motor which is 2.367A at its rated speed 1350rpm.

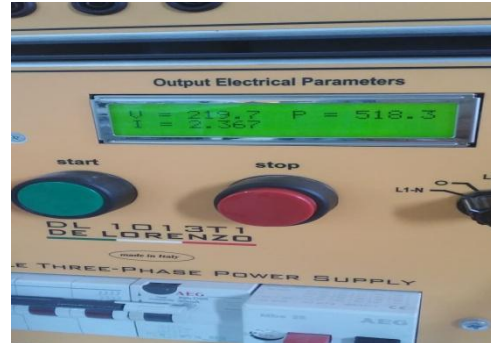

Figure 18. Three-phase ac power supply

Afterwards, VFD is connected to three-phase induction motor. Let's suppose the speed we needed was 1500rpm. Figure.19 shows the desired speed we have achieved in this particular case. At this point, the current is reduced to 0.189A shown in figure.20. Which was 2.367A without connecting VFD. In result power consumption is also reduced[4].



Figure 19. Three-phase Induction motor speed with VFD



Figure 20. Three-phase Induction motor starting current with VFD

The range of frequency achieved using VFD is 5 to 75 Hz, while speed range is from 6 to 2000 rpm shown in table 2.

Table 2. Range of speed and frequency using VFD

Maximum Frequency (Hz)	Maximum Speed(rpm)	Minimum Frequency (Hz)	Minimum speed (rpm)
75 Hz	2000rpm	5 to 7 Hz	6 rpm

IV. ADVANTAGES OF VFD:

Following are the advantages of VFD:

- Improves control process over wide range of speed.
- Saves energy.
- Gives smooth/soft starting acceleration.
- Reduces heating in induction motor.
- Reduces stress on motor.
- Reduces noise and vibration level.
- Increases life of moving parts due to lower operating speed.

V. FUTURE RECOMMENDATION:

a) Programmable Logic Control

This suggested model can be further modified by using programmable logic controller (PLC). By using the PLC memory sequence of instructions can be programmed its purpose is to continuously monitor the critical process parameters and then perform actions accordingly. PLC takes less space and can be easily reprogrammed. This PLC can be connected to any control system and regulates the VFD, which will act as an intermediary for 3-phase induction motor and PLC [5]. The PLC executes the input according to the ladder logic programming and sends the output to VFD. The VFD processes the input of PLC and controls the speed of 3-phase induction motor accordingly. Secondly, the same system can be used to control the speed of multiple motors simultaneously [6].

b) Close Loop Control Model

This proposed model can be modified further by using close-loop PID or PI controller. By using the close-loop control, stability of system will increase. Close-loop control model increases the efficiency and performance of three-phase induction motor [7]. Close-loop scheme artificial intelligence techniques just like fuzzy logic and neural logic etc.

c) Vector Control Scheme

Hardware implementation of newer and intelligence control can be performed by using vector control scheme.

VI. CONCLUSION

Upon completion of this project, it is concluded that, the design of VFD using SPWM technique is proved to be

energy efficient and the most reliable way to control the speed of three-phase squirrel cage induction motor along with smooth starting and energy saving benefit [8]. Even in the applications where high performance and high efficiency are the most concerned factors VFD is the proven system like in conveyor belts in huge goods production industries, cement mills, compressors in Oil and Gas industries, traction drives etc.[9]. Along with hardware design, the software simulations are done to verify the results of project in MATLAB/Simulink 2018 especially for generation of SPWM and inverter circuitry of Software Simulations and results. By using the VFD, we can control the speed as per load requirement due to which energy consumption is reduced. It provides control over the starting and stopping of motor. Thus, for efficient speed control and minimized power consumption we need minimization of energy consumption a VFD must be used with Industrial Induction motors, HVAC Systems and household appliances [10].

ACKNOWLEDGMENT:

I would like express my deepest gratitude to those who have helped me in this research work& Sukkur IBA University for providing me a great research environment.

REFERENCES

1. Mrs.DeepaliS.Shirke,Prof.Mrs. Haripriya, H.Kulkarni,“Microcontroller based speed control of three phase induction motor using v/f method”.International Journal of Scientific and Research Publications, Volume 3, Issue 2, February 2013.
2. Syed UsamaHassan,Hafiz Bilal Akram,“Speed and Frequency Control of AC Induction Motor Using Variable Frequency Drive”, Student Research Paper Conference Vol-2, No-56, July 2015.
3. Prof. Harsha P. Pawar, Miss. Neha S. Chavan, Miss. Ashwini B. Shinde and Miss. Yugandhara S. Chava,“Speed Control of Induction Motor using PWM Technique”.International Journal of Engineering Research & Technology (IJERT), ISSN: 2278-0181, Vol. 4 Issue 04, April-2015.
4. Tamal Aditya.“ Research to study Variable Frequency Drive and its Energy Savings”. International Journal of Science and Research (IJSR), India Online ISSN: 2319-7064.
5. YasarBirbir, H.SelcukNogay,“Design and implementation of PLC based monitoring control system for three-phase induction motors fed by PWM inverter”,International journal of systems applications ,Engineering and development Issue 3, Volume 2, 2008.
6. B. Coetzer and R. Gouws, “Design of a PLC-Based Variable Load, Speed Control System for a Three-Phase Induction Motor”, Southern African Universities Power Engineering Conference, pp. 318-324, January 2016.
7. M.Deepa, “Design of VFD Drive for a 3-Phase Induction Motor”,International journal of innovative research in science Engineering and technology, Vol. 4, Issue 1, January 2015.
8. Kumar, Dine, “Performance Analysis of Three-Phase Induction Motor with AC Direct and VFD”, IOP Conference Series: Materials Science and Engineering, vol. 331, 2018, p. 012025.
9. Pooja Shinde1, RupaliBurungale, Pooja Kale, Purvee Jain “Speed Control of Induction Motor by Using Variable Frequency Drive”, Int. Journal of Engineering Research and Applications ISSN : 2248-9622, Vol. 4, Issue 4(Version 8), April 2014, pp.35-37.
10. TamalAditya,“ Research to study Variable Frequency Drive and its Energy Savings”. International Journal of Science and Research (IJSR), India Online ISSN: 2319-7064 ,Volume 2 Issue 6, June 2013.



Ghulam Akbar has got his B.E in Electrical Engineering

from MUET Jamshoro, Sindh Pakistan in 2013. And Masters in Electrical Engineering from QUEST, Nawabshah Pakistan in 2018. He is currently in the faculty of Electrical (Power) Engineering at Sukkur IBA University, Sindh Pakistan. The area of interest includes Power System Stability, Power System Quality, Power System Protection & Control.



Mahnoor Mughal has got her B.E in Electrical Engineering from Sukkur IBA University, Sindh Pakistan in 2018. She is currently in the faculty of Electrical (Power) Engineering at Sukkur IBA University, Sindh Pakistan. Area of interest are Electrical Machines, Power system quality and control.



Syed Sabir Hussain Shah Bukhair He received his Bachelor of Engineering degree in Electrical Engineering (Power) from Mehran University of Engineering and Technology Jamshoro, Sindh, Pakistan, in 2009, and his Ph.D. in Electronic Systems Engineering from Hanyang

University, South Korea. He is currently serving as an Assistant Professor in the department of Electrical Engineering at Sukkur Institute of Business Administration. His main research interests include Electrical Machines Design, Power Quality, and Power Electronics