

Syntactic Analysis of Spatial Configuration in Indo-Portuguese Houses in Goa



Tony Marcel Nisha, P.Jayasudha

Abstract: *The culture of a place can be understood by analysing its architecture and vice versa. Each place has a unique culture and hence a unique architectural style. Vernacular architecture is a perfect example for displaying the culture of that place, as it is built based on the culture of that place. However, the culture of a place can be changed or altered when it comes in contact with another culture. The degree and dominance of one culture over another, purely depend on the extent to which both the cultures have acculturated. Hence, vernacular architecture which is a reflection of culture also has a natural tendency to change and to accommodate changes and is flexible, adaptable and hence sustainable. There are many factors that lead to a cross-cultural composition like trade links, colonisation, and westernisation etc. among which colonisation plays a major role in the creation of a new culture in the coastal stretch of India. Goa is one such perfect example where cross-cultural miscegenation is seen due to Portuguese colonisation. This paper aims in understanding and evaluating the cross-cultural amalgamation which is reflected in Indo-Portuguese houses through a study and analysis of four case examples in Goa using space syntax.*

Index Terms: Architecture, Colonisation, Cross-Cultural miscegenation, Cultural amalgamation, Indo-Portuguese houses, Space syntax.

I. INTRODUCTION

The reflection of the culture in a house can be understood by analysing the tangible aspects in it like the spatial configuration or the spatial layout or the spatial sequence in that house. The spatial configuration or spatial layout of a house is based on the activities that are performed in that house which in turn is a reflection of their behavioural pattern (Thungsakul, 2001). Spatial configuration study is hence one of the most important ways to analyse the culture of a place as it directly displays the relationship between the spaces within a house and about the spatial sequences followed in that house (Maina, 2012). The layout of the building displays the ordering of the spaces and their relation to the surrounding natural and built environment (Rapoport, 1969).

This leads to an understanding of the cultural significance of the place or the society by analysing the architectural elements which symbolically convey meanings and its treatments (such as position and size of doors, windows, ornamental details etc.) in the building (Bandyopadhyay, 2008). The traditional vernacular houses of Goa display their strong cultural character with introverted planning, small or no openings towards their street, separate spaces for women and a Pooja space displaying their strong religious belief system. However, this style of houses started to vanish and a new architectural style called the Indo-Portuguese style started to gain its popularity around the middle of the 18th and 20th centuries.

The impact of Portuguese on Goa is very huge that it is hard to say that Goa belongs to India. The arrival of Portuguese in Goa in 1510 had brought a change in the religion of natives by converting them to Christians and the change reflected in their culture (Pearson, 2008). Religious conversion played a major role in the upbringing of this new style. The converted Christians adopted the new style primarily, followed by some of the Hindus. However, the degree to which the Christians and Hindus adopted the new style differed (Pandurang, 2003). The introverted house plans, converted into extroverted plans but with a varying degree based on their religion, thus resulting in a unique cross-cultural composition. Portuguese culture influenced the art, architecture, culinary habits, food, dressing style etc., and resulted in the creation of a new style (Teixera, 1990). The inmates also accepted it as a replacement for their traditional vernacular style. By analysing the spatial configuration of Indo-Portuguese houses, degree of cross-cultural integrity can be understood.

II. RESEARCH FOCUS AND METHODOLOGY:

The research focusses on evaluating the cross-cultural amalgamation in Indo-Portuguese houses. For the purpose, four houses are selected, documented and studied in detail from the Old Quarter area, which consists of four wards namely, Sao Tome, Fontainhas, Mala and Portais, which are bounded by the Ourem creek on the east, the Altinho hill on the west, the Mandovi River on the north and the rest of the Panjim city on the south. The houses were analysed based on the details collected from the literature study, field study, observation and interaction with the inmates. Space syntax was used as a quantifying tool for analysing the spatial configuration of the houses, through which the cross-cultural amalgamation can be understood.

Revised Manuscript Received on 30 July 2019.

* Correspondence Author

Tony Marcel Nisha*, Department of Architecture, Periyar Maniammai Institute of Science and Technology, Thanjavur, India.

Dr.P.Jayasudha, Department of Architecture, Periyar Maniammai Institute of Science and Technology, Thanjavur, India.

© The Authors. Published by Blue Eyes Intelligence Engineering and Sciences Publication (BEIESP). This is an [open access](https://creativecommons.org/licenses/by-nc-nd/4.0/) article under the CC-BY-NC-ND license <http://creativecommons.org/licenses/by-nc-nd/4.0/>

III. SPACE SYNTAX:

Space syntax is a tool used to quantify the spatial configuration in a building and their underlying social logic behind it (Hillier, 2005). A set of buildings from the same culture, society etc, following similar social norms, values etc., will have similar values. Through space syntax calculations one can understand the depth of the overall building, the pattern of spatial organisation in the building, the degree of influence exerted by each space in the building and to understand the most integrated space and the least integrated space in the building (Hillier, 2009). Hence by comparing the values obtained from space syntax, one can understand the underlying intangible aspects of architecture, by which their cultural pattern can be traced.

IV. INDO – PORTUGUESE HOUSES IN PANAJI, GOA:

Indo-Portuguese houses in Goa have a perfect blend of both Portuguese and Indian architecture and the perfect example for cross-cultural miscegenation. The extroverted planning with balcoes, verandas and balcony, unlike the traditional introverted plan, display their western culture, while the separate domain for the women and the presence of Tulsi Vrindavan in the house reveals the Indian culture in it. These houses also adapt well to the climate of Goa, by employing various techniques like providing a small gap near the roof for ventilation. These houses were initially either owned only by the Indians who were converted Christians or by the Indians who worked under the Portuguese administration or by the Indians who were married to people belonging to Portuguese origin etc. The Portuguese treated the Christian converts equally and gave them higher posts in society. This increased the number of religious conversions and the converted Christians started accepting the culture of Portuguese as their way of life (Pandurang, 2003). It was later also owned by Hindus who held high positions in the Portuguese government (Nadkarni, 2003). Thus, the spatial configuration of their houses reflects their religious and cultural differences.

The settlement planning was based on the hierarchy of the official's cadre, unlike the hierarchy of caste systems in vernacular architecture. The officials belonging to higher rank resided at an elevated area while the people belonging to lower cadre resided at a lower level. The streets were laid in a meandering pattern, based on the topography of the area and eventually opened up into a square, which was formed based on the topography of the area or the location of a grotto, church etc. further enhancing communal bonding. The houses were built very close to one another and even had shared walls in many places, displaying their strong communal bonding.

The Indo-Portuguese Hindu houses incorporated Portuguese characters in their houses but did not cut themselves from their cultural and religious roots. They still followed an introverted plan with the spatial layout based on privacy concerns. The Indo-Portuguese Hindu houses have no openings facing the street and are devoid of balcoes and balconies, unlike the Christian houses. The houses are placed in such a way, that the main door of each house does not face the main door of the house located opposite to it

(Nadkarni, 2003). The hierarchy of spaces are in the order of semi-private to private zones and are clearly demarcated. Women are given utmost privacy and outsiders are not allowed to enter the women's zone in Indo-Portuguese Hindu houses. The women's zone consists of spaces like kitchen, dining and backyard spaces. On the contrary, the Christian houses are extroverted and women are allowed to move freely within the house. Both the houses have a worshipping space within the house. The Hindu houses have a Pooja space in the dining area, which is considered very sacred and have accessibility only for inmates and certain guests. They have two dining areas, which are used for specific purposes. The Christians have an altar, which is present in the living area or in the dining area, as they believe in communal prayer.

V. SAMPLE SELECTION AND DESCRIPTION:

Samples are selected randomly based on the typologies as the Indo-Portuguese house with courtyard (typology 1) and Indo-Portuguese house without courtyard (typology 2). Two samples are selected from each typology thus having a total of four samples. All the selected samples belong to the late 18th and early 19th century and are hence more than 200-250 yrs old.

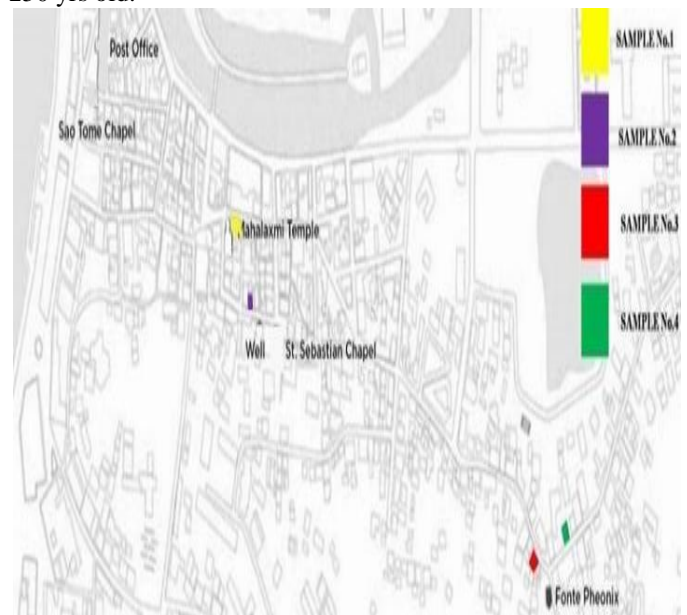

Fig.1: Map showing the location of samples

VI. EVALUATION OF SPATIAL SEQUENCE:

For the purpose of evaluating the spatial configuration of a house by using space syntax as a tool, the following aspects are to be calculated. The depth values of all the spaces in a building – in order to know whether the overall system is deep or shallow i.e, whether the spaces are arranged linearly or clustered. Composition or distribution of spaces in a building – in order to understand the scale of symmetry in buildings and to know the range of the spaces from most integrating to least integrating into a system. The character of individual space, the force exerted by a space in the system.

A. Depth values:

The first step involved in space syntax is the formulation of an access graph. Space codes are allotted for each space and are denoted as circles and the access to it are denoted by lines. This graph is further converted into J-Graphs or accessibility diagram. In J-Graphs, any one space is taken as reference and the rest of the spaces are arranged in a sequential pattern above it in levels, L (Oswald, 2011). The level from which the reference space starts is 0, and the spaces connected to the reference will be at different levels starting from level 1. Through this graph, the total depth, TD of the building can be calculated. The Total Depth of a node or reference is nothing but the total number of connections between a node and every other node in the set, multiplied by its corresponding level. If there are X levels in a building, then TD can be calculated as,

$$TD = (0 * n_0) + (1 * n_1) + (2 * n_2) + \dots + (X * n_x) \dots \text{Formula 1,}$$

where K, is the total number of spaces in a building and nx, is the total number of nodes or spaces in a building.

The Mean depth, MD is nothing but the average degree of depth of a node in J-Graph and is calculated by;

$$MD = \frac{TD}{(K-1)} \dots \text{Formula 2.}$$

The lower the value of MD of space, the more easily it is accessible within the building and vice versa.

B. Composition or distribution of spaces in a building:

In order to find out how each space is connected to the other spaces in the system, so as to know, which space integrates the whole system and which space is left isolated, the Relative Asymmetry, RA is calculated. By using the MD values, RA values are calculated.

$$RA = \frac{2(MD-1)}{K-2} \dots \text{Formula 3.}$$

RA values are normalised with respect to their relative depth and hence has a range of values, between 0.0 to 1.0. Since RA values depend on the spatial arrangement of spaces, the relative depth, and also on the size of the system, i.e. no. of spaces. It can be used to compare buildings having the same total number of spaces. If K values differ widely in the samples, then Real Relative Asymmetry, RRA is calculated. RRA is the ratio between RA and a Dk which is a common factor that is based on the size of the system. RRA is calculated by

$$RRA = \frac{RA}{DK} \dots \text{Formula 4.}$$

Dk factor for a K can be calculated using Hillier and Hanson's table.

A higher RRA value indicates that space is more isolated while lower RRA values indicate that space is more integrated with the other spaces. By analysing the RRA values of all the spaces in the house, a spatial pattern by which they have arranged the spaces can be found. If all the samples have a similar set of patterns then the cultural background of the building can be traced.

C. The character of individual space, the force exerted by a space in the system:

The Control Value, CV, of a system, helps in finding out the degree of influence exerted by a space in the whole system and helps in understanding the spaces that play a major role in controlling the overall system. It is calculated by

implementing the following steps. The total number of spaces that are connected to a node, C, is calculated. Each space that is connected with the node, imparts a control value, Cve, that is shared to that node with a value of 1/n of its total control value and hence is calculated by the formula, Cve = 1/C of that space.....Formula 5

Thus the CV of a node or reference is nothing but the total number of shared control values of all the spaces that has a connection with that node or reference (Paul, 2011).

VII. SPATIAL CODES FOR ALL THE SPACES IN THE SAMPLES:

Spaces	Legends
Exterior	Ext
Living	Li
Passage 1	P1
Passage 2	P2
Guest Bedroom	GBd
Bedroom	Bd
Pooja	Po
Praying space	Pr
Dining 1	D1
Dining 2	D2
Store	S
Kitchen 1	Ki1
Kitchen 2	Ki2
Backyard	BY
Bath/Toilet	Bt/T

A. Sample No. 1:

The selected sample 1, a two-storied structure belonging to a Christian family, which is located in the Sao Tome area is identified as one of the case examples for typology 1 (Indo-Portuguese house with Courtyard). The house is entered from a passage which has a flight of stairs to reach the first floor and has an entry to the guest bedroom. The passage then leads to the living room which has the master bedroom on one side and the dining spaces on the other side. The altar space or chapel is also present in the living area. The dining opens out to the store, the kitchen and a courtyard. The bath/Toilet space opens out from the dining area.

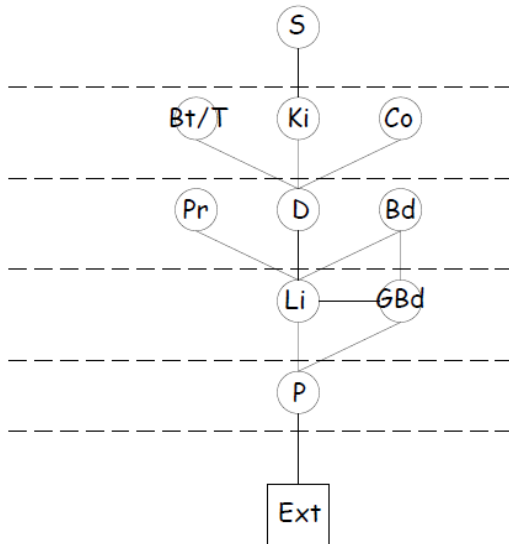
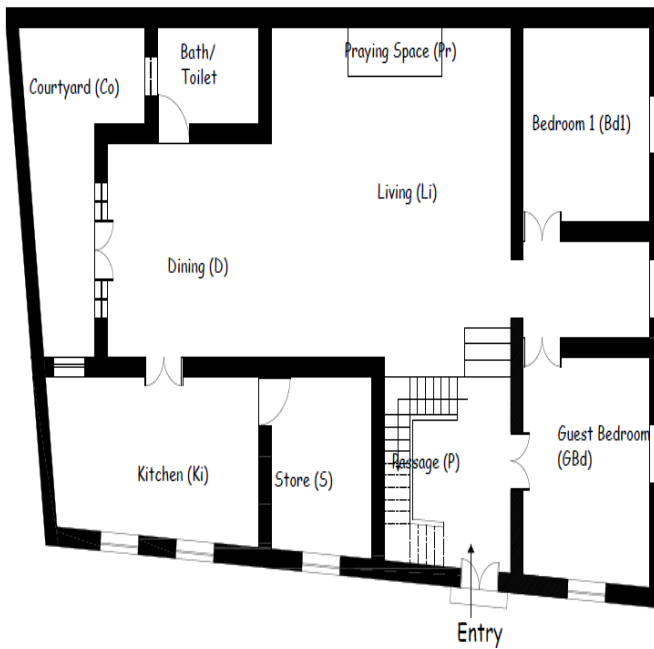

Fig.2: Plan of Sample No.1b. J-Graph of Sample No.1

The various values related to the spatial configuration are calculated using the formulae 1, 2, 3, 4 and 5 (as tabulated in the table below).

S.No	Sample No.1	Ext	P	L	GBd	Bd	D	Ch	S	K	C	Bt/T	TDn	MDn	RA	RRA
1	Ext	0	1	2	2	3	3	3	5	4	4	4	31	3.100	0.467	1.582
2	P	1	0	1	1	2	2	2	4	3	3	3	22	2.200	0.267	0.904
3	L	2	1	0	1	1	1	1	3	2	2	2	16	1.600	0.133	0.452
4	GBd	2	1	1	0	1	2	2	4	3	3	3	22	2.200	0.267	0.904
5	Bd	3	2	1	1	0	2	2	4	3	3	3	24	2.400	0.311	1.055
6	D	3	2	1	3	2	0	2	2	1	1	1	18	1.800	0.178	0.603
7	Ch	3	2	1	3	2	2	0	4	3	3	3	26	2.600	0.356	1.205
8	S	5	4	3	5	4	2	4	0	1	3	3	34	3.400	0.533	1.808
9	K	4	3	2	3	3	1	3	1	0	2	2	24	2.400	0.311	1.055
10	C	4	3	2	4	3	1	3	3	2	0	2	27	2.700	0.378	1.281
11	Bt/T	4	3	2	4	3	1	3	3	2	2	0	27	2.700	0.378	1.281
MEAN													271	27.100	3.578	12.128
MEAN													24.636	2.464	0.325	1.103

Table 1. Calculation of depth and integration values for Sample No.1

S.No	Sample No.1	Ext	P	L	GBd	Bd	D	Ch	S	K	C	Bt/T	NCn	Cve	CV
1	Ext	0	1	0	0	0	0	0	0	0	0	0	1	1.00	0.33
2	P	1	0	1	1	0	0	0	0	0	0	0	3	0.33	1.53
3	L	0	1	0	1	1	1	1	0	0	0	0	5	0.20	2.42
4	GBd	0	1	1	0	1	0	0	0	0	0	0	3	0.33	1.03
5	Bd	0	0	1	1	0	0	0	0	0	0	0	2	0.50	0.53
6	D	0	0	1	0	0	0	0	0	1	1	1	4	0.25	2.70
7	Ch	0	0	1	0	0	0	0	0	0	0	0	1	1.00	0.20
8	S	0	0	0	0	0	0	0	0	1	0	0	1	1.00	0.50
9	K	0	0	0	0	0	1	0	1	0	0	0	2	0.50	1.25
10	C	0	0	0	0	0	1	0	0	0	0	0	1	1.00	0.25
11	Bt/T	0	0	0	0	0	1	0	0	0	0	0	1	1.00	0.25
MEAN															11.00
MEAN															1

Table 2. Calculation of control values for Sample No.1

The low depth value for the living, dining, passages and guest bedrooms proves that these spaces are easily accessible from all the spaces in the house and have high control value, as they integrate the semi-private areas with private areas. High depth values for kitchen, store and bath/Toilet spaces showcase that these spaces are isolated from the rest of the spaces in the house, as they are either service spaces or private spaces. These spaces also have low control values as these spaces have specific activities and hence also do not branch out to other spaces. The Chapel space has an intermediate value in the scale, because it is present in the living room but does not impart any value to the other spaces in the house. The courtyard space is located at the rear end of the house and is accessed only from the dining space, unlike the traditional vernacular architecture of Goa and hence has a low control value. The courtyard connects the spaces of the house with the outdoor visually and not physically and hence the high depth values and low control values.

B. Sample No.2:

The selected sample 2, a single-storied structure belonging to a Hindu family, which is located in the Mala area is identified as one of the case examples for typology 1, (Indo-Portuguese houses with courtyard). The planning of this house is based on the Traditional Hindu house with a central courtyard. All the spaces are located around the courtyard as in a traditional Goan house, but still adopts certain elements from the Portuguese architecture like the presence of openings in the periphery of the building and the façade detailing etc. The details in the doors and windows are also minimal when compared to other houses but strictly adhere to the rule of following colour codes in the buildings. A strict demarcation between the men and women spaces and also between semi-private and private spaces can be seen. Two Kitchen and Dining area are present in this house for different purposes. A well is located in such a way that it can be accessed from both the kitchen and bath areas.

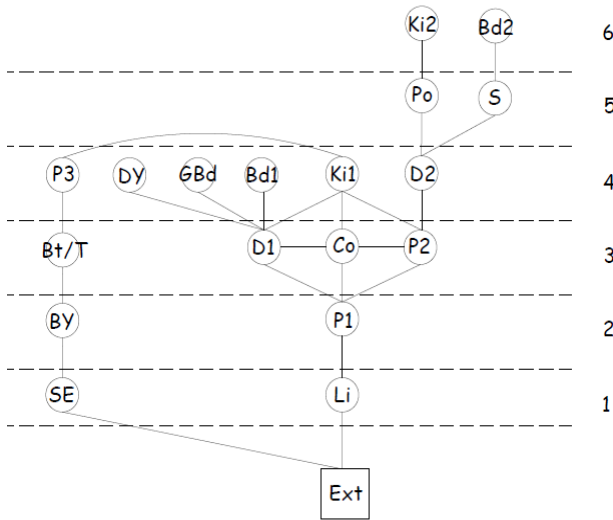
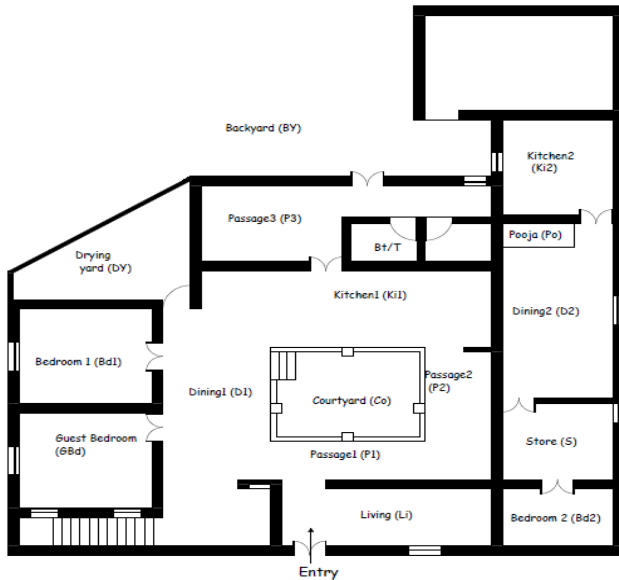

Fig.3: Plan of Sample No.2 b. J-Graph of Sample No.2

The various values related to the spatial configuration are calculated using the formulae 1, 2, 3,4 and 5 (as tabulated in the table below).

S.No	Sample No.2	Ext	L	P1	Bd1	Bd2	C	FD	P2	K1	D2	Po	S	K	Bd3	B/T	BY	Tdn	Mdn	RA	RRR
1	Ext	0	1	2	4	4	3	3	3	4	4	5	5	6	6	5	6	61.00	4.07	0.44	1.75
2	L	1	0	1	3	3	2	2	2	3	3	4	4	5	5	4	5	47.00	3.13	0.30	1.21
3	P1	2	1	0	2	2	1	1	1	2	2	3	3	4	4	3	4	35.00	2.33	0.19	0.76
4	GBd	4	3	2	0	2	2	1	3	2	4	5	5	6	6	3	4	52.00	3.47	0.35	1.40
5	Bd1	4	3	2	2	0	2	1	3	2	4	5	5	6	6	3	4	52.00	3.47	0.35	1.40
6	C	3	2	1	2	2	0	1	1	1	2	3	3	4	4	2	3	34.00	2.27	0.18	0.72
7	D1	3	2	1	1	1	0	2	1	3	4	4	5	5	2	3	38.00	2.53	0.22	0.87	
8	P2	3	2	1	3	3	1	2	0	1	1	2	2	3	3	2	3	32.00	2.13	0.16	0.65
9	K1	4	3	2	3	3	1	2	2	0	3	4	4	5	5	1	2	44.00	2.93	0.28	1.10
10	D2	4	3	2	4	4	2	3	1	2	0	1	1	2	2	3	4	38.00	2.53	0.22	0.87
11	Po	5	4	3	5	5	3	4	2	3	1	0	2	3	1	4	5	50.00	3.33	0.33	1.33
12	S	5	4	3	5	5	3	4	2	3	1	2	0	3	1	4	5	50.00	3.33	0.33	1.33
13	K	6	5	4	6	6	4	5	3	4	2	3	1	0	4	5	6	64.00	4.27	0.47	1.86
14	Bd2	6	5	4	6	6	4	5	3	4	2	3	1	4	0	5	6	64.00	4.27	0.47	1.86
15	B/T	5	4	3	3	3	2	2	1	3	4	4	5	5	0	1	4	47.00	3.13	0.30	1.21
16	BY	6	5	4	4	4	3	3	3	2	4	5	5	6	6	1	0	61.00	4.07	0.44	1.75
MEAN																		769.00	51.27	5.04	20.07
MEAN																		48.06	3.20	0.31	1.25

Table 3. Calculation of depth and integration values for Sample. No.2

S.No	Sample No.2	Ext	L	P1	Bd1	Bd2	C	FD	P2	K1	D2	Po	S	K	Bd3	B/T	BY	NCn	Cve	CV	
1	Ext	0	1	0	0	0	0	0	0	0	0	0	0	0	0	0	0	0	1	1.00	0.50
2	L	1	0	1	0	0	0	0	0	0	0	0	0	0	0	0	0	0	2	0.50	1.25
3	P1	0	1	0	0	0	1	1	1	0	0	0	0	0	0	0	0	0	4	0.25	1.20
4	GBd	0	0	0	0	0	0	1	0	0	0	0	0	0	0	0	0	0	1	1.00	0.20
5	Bd1	0	0	0	0	0	0	1	0	0	0	0	0	0	0	0	0	0	1	1.00	0.20
6	C	0	0	1	0	0	0	1	1	1	0	0	0	0	0	0	0	0	4	0.25	1.20
7	D1	0	0	1	1	1	1	0	0	1	0	0	0	0	0	0	0	0	5	0.20	3.00
8	P2	0	0	1	0	0	1	0	0	1	1	0	0	0	0	0	0	0	4	0.25	1.33
9	K1	0	0	0	0	0	1	0	0	0	0	0	0	0	0	0	1	0	2	0.50	0.75
10	D2	0	0	0	0	0	0	0	1	0	0	1	1	0	0	0	0	0	3	0.33	1.75
11	Po	0	0	0	0	0	0	0	0	0	0	1	0	0	0	1	0	0	2	0.50	1.33
12	S	0	0	0	0	0	0	0	0	0	0	1	0	0	0	1	0	0	2	0.50	1.33
13	K	0	0	0	0	0	0	0	0	0	0	0	1	0	0	0	0	0	1	1.00	0.50
14	Bd2	0	0	0	0	0	0	0	0	0	0	0	1	0	0	0	0	0	1	1.00	0.50
15	B/T	0	0	0	0	0	0	0	0	1	0	0	0	0	0	0	1	0	2	0.50	1.50
16	BY	0	0	0	0	0	0	0	0	0	0	0	0	0	0	0	1	0	1	1.00	0.50
MEAN																			17.05	1.07	

Table 4. Calculation of control values for Sample. No.2

The tables show that the house has a clear demarcation of semi-private, private and the most private spaces based on their depth values. The passages, courtyards, living and dining spaces have low Depth values while the bedrooms, kitchen and Pooja have high depth values, as the former spaces are semi-private in nature while the later spaces are private spaces respectively. The values prove that the dining space for the guests is located at very close proximity from the exterior and is also well connected with spaces like guest bedrooms, courtyard and living areas. The high control value for the semi-private spaces proves its connection with the most private parts of the house like the kitchen, Pooja, store and bedroom3.

C. Sample No. 3:

The selected sample 3, a two-storied structure belonging to a Christian family, which is located in the Sao Tome area is identified as one of the case examples for typology 2 (Indo-Portuguese house without Courtyard). The house is located near St. Sebastian's Chapel. The house does not have a balcao or a veranda, as they belong to the 18th century. The ground floor of the house is used as a garage. The entry to the house is through a passage, from which one enters the living area. The altar space is located in the living area. The living area opens out to the dining and to the Guest bedroom. One of the most noticeable features of Portuguese architecture is the connecting door between the guest bedroom and the master bedroom. The dining opens out to the master bedroom on one side and the store on the other side. A passage from the dining, connects the backyard, kitchen and the Bath/Toilet space. The layering of spaces based on the gender and category can be seen very well in this house.

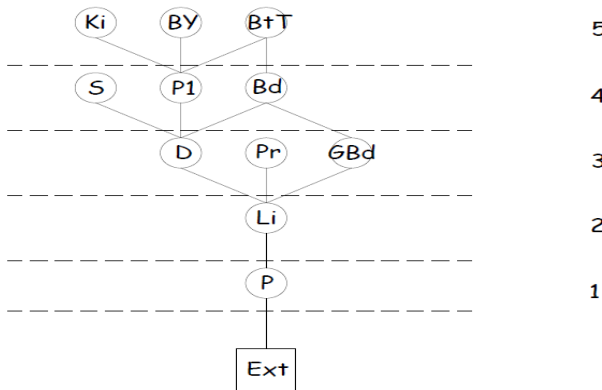
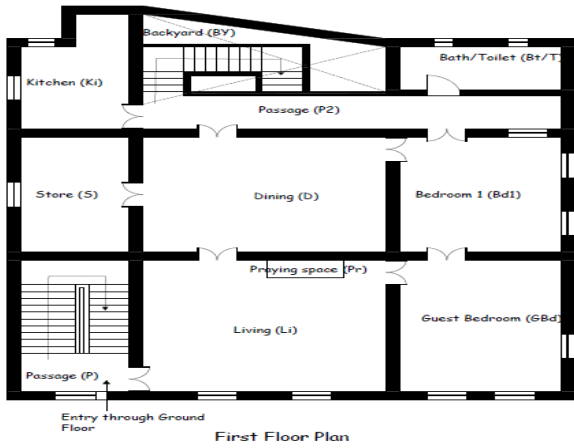

Fig.4: a. Plan of Sample No.3, b. J-Graph of Sample No.3

The various values related to the spatial configuration are calculated using the formulae 1, 2, 3,4 and 5 (as tabulated in the table below).

S.No	Sample No.3	Ext	L	P	P1	Ch	D	GBd	Bd	K	S	BY	Bt/T	TDn	MDn	RA	RRA
1	Ext	0	2	1	4	3	3	3	4	5	4	5	5	39	3.545	0.509	1.786
2	L	2	0	1	2	1	1	1	2	3	2	3	3	21	1.909	0.182	0.638
3	P1	1	1	0	3	2	2	2	3	4	3	4	4	29	2.636	0.327	1.148
4	P2	4	2	3	0	3	1	3	2	1	2	1	1	23	2.091	0.218	0.766
5	Ch	3	1	2	3	0	2	2	3	4	3	4	4	31	2.818	0.364	1.276
6	D	3	1	2	1	2	0	2	1	2	1	2	2	19	1.727	0.145	0.510
7	GBd	3	1	2	3	2	2	0	1	4	3	4	2	27	2.455	0.291	1.021
8	Bd	4	2	3	2	3	1	1	0	3	2	3	1	25	2.273	0.255	0.893
9	K	5	3	4	1	4	2	4	3	0	3	2	2	33	3.000	0.400	1.404
10	S	4	2	3	2	3	1	3	2	3	0	3	3	29	2.636	0.327	1.148
11	BY	5	3	4	1	4	2	4	3	2	3	0	2	33	3.000	0.400	1.404
12	Bt/T	5	3	4	1	4	2	2	1	2	3	2	0	29	2.636	0.327	1.148
MEAN														28.17	2.56	0.31	1.10

Table 5. Calculation of depth and integration values for Sample. No.3

S.No	Sample No.3	Ext	L	P	P1	Ch	D	GBd	Bd	K	S	BY	Bt/T	NCn	Cve	CV
1	Ext	0	0	1	0	0	0	0	0	0	0	0	0	1	1.00	0.50
2	L	0	0	1	0	1	1	1	0	0	0	0	0	4	0.25	2.25
3	P1	1	1	0	0	0	0	0	0	0	0	0	0	2	0.50	1.25
4	P2	0	0	0	0	0	1	0	0	1	1	1	1	4	0.25	2.75
5	Ch	0	1	0	0	0	0	0	0	0	0	0	0	1	1.00	0.25
6	D	0	1	0	1	0	0	0	1	0	1	0	0	4	0.25	1.58
7	GBd	0	1	0	0	0	0	0	1	0	0	0	0	2	0.50	0.58
8	Bd	0	0	0	0	0	1	1	0	0	0	0	1	3	0.33	1.25
9	K	0	0	0	1	0	0	0	0	0	0	0	0	1	1.00	0.25
10	S	0	0	0	0	0	1	0	0	0	0	0	0	1	1.00	0.25
11	BY	0	0	0	1	0	0	0	0	0	0	0	0	1	1.00	0.25
12	Bt/T	0	0	0	1	0	0	0	1	0	0	0	0	2	0.50	0.58
MEAN																11.75
MEAN																0.98

Table 6. Calculation of control values for Sample. No.3

The table shows that the living, dining, passageway, as well as the guest bedrooms and bedrooms, have low depth values, as they are located in close proximity to all the spaces. The guest bedrooms and bedroom spaces are connected and are placed near the living as the inmates wanted to make sure that their guests were comfortable and this is reflected in the syntactic data of their house. The Kitchen, Bath/Toilet, Store, are all not connected to any other spaces as they have a specific function and hence have a low control value. They are also placed away from the semi-private and private zones as these spaces were to be used only by the inmates. The chapel space has neither a low depth value nor a high depth value as it is placed in the living room but does connect with other spaces. It hence has a low control value.

D. Sample No. 4:

The selected sample 4, a single-storied structure belonging to a Hindu family, which is located in the Mala area is identified as one of the case examples for typology 2, (Indo-Portuguese houses without courtyard). This house has a linear plan and the spatial layout of the house is similar to a Catholic house (living, guest bedroom and bedroom spaces located next to each other), but is configured differently. It has two dining and kitchen spaces as the Pooja space are located in one of the dining space and hence is considered very sacred. The Guest Bedroom is located next to the Living room. Well is located in the backyard along with Bath/Toilet and the second Kitchen.

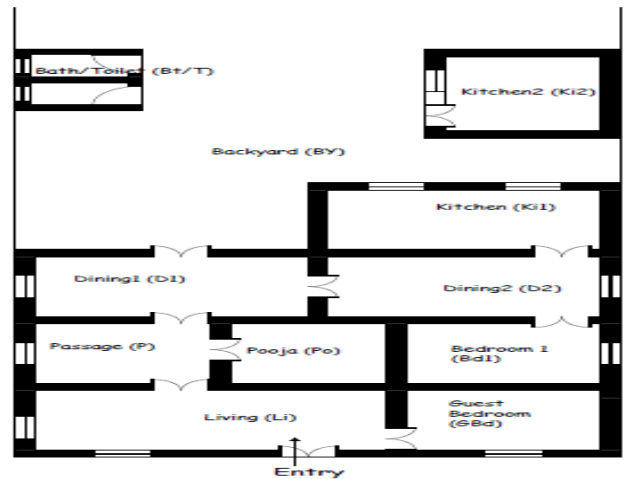

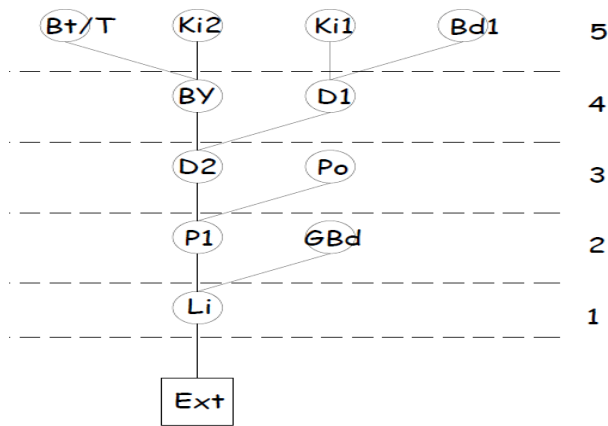

Fig.5: Plan of Sample No.4 J-Graph of Sample No.4

The various values related to the spatial configuration are calculated using the formulae 1, 2, 3,4 and 5 (as tabulated in the table below).

S.No	Sample No.4	Ext	L	P1	GBd	BD	Po	D1	D2	K1	K2	BY	Bt/T	TDn	MDn	RA	RRa
1	Ext	0	1	2	2	5	3	4	3	5	5	4	5	39	3.545	0.509	1.786
2	L	1	0	1	1	4	2	3	2	4	4	3	4	29	2.636	0.327	1.148
3	P1	2	1	0	2	3	1	2	1	3	3	2	3	23	2.091	0.218	0.766
4	GBd	2	1	2	0	5	3	4	3	5	5	4	5	39	3.545	0.509	1.786
5	Bd	5	4	3	5	0	4	1	2	2	4	3	4	37	3.364	0.473	1.659
6	Po	3	2	1	3	4	0	3	2	4	4	3	4	33	3.000	0.400	1.404
7	D1	4	3	2	4	3	3	0	1	3	1	1	2	27	2.455	0.291	1.021
8	D2	3	2	1	3	2	2	1	0	2	2	1	2	21	1.909	0.182	0.638
9	K1	5	4	3	5	2	4	1	2	0	4	3	4	37	3.364	0.473	1.659
10	K2	5	4	3	5	2	4	1	2	4	0	3	4	37	3.364	0.473	1.659
11	BY	4	3	2	4	3	3	2	1	3	1	0	1	27	2.455	0.291	1.021
12	Bt/T	5	4	3	5	2	4	1	2	4	4	3	0	37	3.364	0.473	1.659
MEAN														32.167	2.924	0.385	1.350

Table 7. Calculation Of Depth And Integration Values For Sample. No.4

S.No	Sample No.4	Ext	L	P1	GBd	BD	Po	D1	D2	K1	K2	BY	Bt/T	NCn	Cve	CV
1	Ext	0	1	0	0	0	0	0	0	0	0	0	0	1	1.00	0.33
2	L	1	0	1	1	0	0	0	0	0	0	0	0	3	0.33	2.33
3	P1	0	1	0	0	0	1	0	1	0	0	0	0	3	0.33	1.67
4	GBd	0	1	0	0	0	0	0	0	0	0	0	0	1	1.00	0.33
5	Bd	0	0	0	0	0	0	1	0	0	0	0	0	1	1.00	0.33
6	Po	0	0	1	0	0	0	0	0	0	0	0	0	1	1.00	0.33
7	D1	0	0	0	0	1	0	0	1	1	0	0	0	3	0.33	2.33
8	D2	0	0	1	0	0	0	1	0	0	0	1	0	3	0.33	1.00
9	K1	0	0	0	0	0	0	1	0	0	0	0	0	1	1.00	0.33
10	K2	0	0	0	0	0	0	1	0	0	0	0	0	1	1.00	0.33
11	BY	0	0	0	0	0	0	0	1	0	1	0	1	3	0.33	2.33
12	Bt/T	0	0	0	0	0	0	1	0	0	0	0	0	1	1.00	0.33
MEAN																12.00
MEAN																1.00

Table 8. Calculation of control values for Sample. No.4

The space syntax table proves that the living, dining and passage areas are well integrated and have many connections from them thus having low depth values and high integration values. The backyard also has a low depth and high integration value as it integrates all the women area like kitchen, store, Tulsi Vrindavan etc. The bedrooms and

guestbedrooms, kitchen spaces etc., all have specific functional activities and are not connected to the rest of the house, in order to maintain privacy as per their traditional Indian culture and hence have high total depth and mean depth values. Thus, we can conclude that the semi-private and the linking spaces in the house integrate well to other spaces in the house, while the private spaces like kitchen are isolated for privacy reasons based on their culture.

VIII. MOVEMENT PATTERN:

The role of women in society is one of the most important factors that differentiate culture from another. The privacy levels and the way it is achieved helps in understanding the cultural pattern of that society. Thus, by analysing the movement pattern within the house, based on gender and activities, one can understand its spatial arrangement based on their underlying culture. From the above analysis, we can conclude that the spaces in the Hindu houses follow gender stratification, as women have a separate domain of their own in all these houses and arranged away from the semi-private areas of the house. In the case of Christian houses, women domain is present in the house but is not as private as in the case of a Hindu house but positioned away from the semi-private areas.

IX. RESULTS AND DISCUSSION:

It is found from the study and analysis, that the spaces in Indo-Portuguese houses are grouped into different categories based on the function, location etc. as, private spaces, semi-private spaces, linking spaces and service spaces.

A. Semi-Private areas:

In Traditional Indian Vernacular houses, living, dining and thinnai spaces fall under the

semi-private category. In Indo-Portuguese Christian houses, the spaces that fall under semi-private spaces are balconies, balconies, living, dining and praying spaces too, as they believe in communal prayer. In Indo-Portuguese Hindu houses, only living and dining (Common dining space, D1) spaces fall under the semi-private category. Pooja space is considered as a private space, unlike the Christian praying space. From the table, it is inferred that dining and living spaces have a low access level as they are placed in the front and have a low mean depth value, as they are easily accessible from all the spaces in the house. Hence, they have high control value among all the spaces and in all the four houses. This is because both the Indian and the Portuguese had a custom of welcoming their guests, offer food and entertain them in their house. The semi-private areas are then connected to the private areas of the house, through linking spaces.

B. Linking spaces:

Courtyards and Passages act as linking spaces in Traditional Indian houses and in Indo-Portuguese Hindu houses. Courtyard spaces are usually present in all Indian Traditional houses, as they help in modifying the climate of India.



Syntactic Analysis of Spatial Configuration in Indo-Portuguese Houses in Goa

In Indo-Portuguese Christian houses, only, passages act as linking spaces. They connect the semi-private spaces with the other semi-private spaces in the house and with the private spaces in the house. Hence, passages have the highest control values of all spaces in all the samples. Courtyards are positioned in the centre in Indo-Portuguese Hindu houses as they follow introverted planning and link all the spaces with one another. On the contrary in Indo-Portuguese Christian Houses, courtyards are located at the periphery of the house, as they like to be closely connected to nature. It is located near the dining or the bedroom spaces to either facilitate open dining or as patio space etc. Hence, courtyards also have high control values in Indo-Portuguese Hindu houses.

C. Private areas:

Bedrooms, Kitchen, Pooja and even dining in certain cases are considered as private spaces in Traditional Indian houses. In Indo-Portuguese Hindu houses, all the above-mentioned spaces are considered as private spaces. The bedroom is the most private space in the house. On the contrary, according to Western culture, guests are considered important and hence the master bedrooms are placed next to the guest bedrooms so that the inmates are able to take care of them. In Indo-Portuguese Christian houses, bedrooms were not considered as private as that of Indian culture. There is a door, connecting the guest bedroom and the master bedroom, which proves this statement. Bedrooms, hence have low control values in Hindu houses the Christian houses and the access levels and mean depth values of Bedroom spaces are lower in Christian houses than in Hindu houses. Pooja space is considered very sacred and is restricted only to the inmates, relatives and certain guests. They invite only the most important guests for dining in Hindu houses and hence have low control value and high mean depth. These spaces do not give access to any other spaces in the house. The Christians follow a system of communal prayer and hence the praying space is located either in the hall or in the dining space itself. In certain cases, the dining and the living spaces are located in the same area with a partition in between. Hence, the Praying space is not considered as private like in the case of Hindu houses and has a low control value and high mean depth. They do not have the least control value but fall next to the service spaces. Almost all Indo-Portuguese Hindu houses have two dining spaces – one where the Pooja space is located and the other used for the consumption of non-vegetarian food. Kitchen is considered as a private space in both Indo-Portuguese Hindu and Christian houses, as they are used only by the women folks. They are hence located at the rear end of the house and have high mean depth value. The kitchen plays an important domain in the women's zone, connecting dining and backyard spaces and hence, also have high control values.

D. Service Spaces:

The service spaces in Traditional Indian houses include spaces like store, backyard etc. and remain the same in both Indo-Portuguese Hindu and Indo-Portuguese Christian houses. These spaces fall under the women's domain and under the servants and are hence positioned at the end of the house. They have the lowest control value in the house, as they have a specific function and are not connected to many

spaces. The servants have a separate entrance to the house but are not mandatory in Christian houses, unlike Hindu houses. The access level and the Mean Depth MD, for these spaces, are hence the highest of all spaces in the house.

X. CONCLUSION:

From the above analysis, it is found that there are certain parameters, which have led to a difference in the degree and dominance of one culture over the other. The analysis proves that religion is one of the major parameters in creating a difference in the degree of their amalgamation. The other underlying factors in creating this difference are social status, occupation and mixed marriages. All these factors are interconnected to one and another. One of the most unique characters of Indo-Portuguese houses is the presence of balconies, which is a combination of both veranda and thinnai spaces. The positioning of the main door ensuring maximum privacy shows the essence of Indian culture. Traditional Indian houses have large openings on the first floor, for the women to view the street activities while balconies are part of western houses. In Indo-Portuguese, the presence of both balconies and large openings on the first floor shows the amalgamation of both the cultures. The courtyard is one of the major space in traditional Indian houses, as the entire activities take place around it. In Indo-Portuguese houses, these spaces are used differently.

Either they are placed near the dining or bedroom areas to facilitate outdoor dining or act as patios, as these houses are positioned in a row or as clusters. The spatial layout and the organisation of both the Indo-Portuguese Christian and Hindu houses are the same, but there is a difference in their spatial configuration. This is because the degree of privacy for space varied with respect to Christians and Hindus. This can be understood by the location and connectivity between the guest bedroom and master bedroom in all the samples. The role of women in the society in both the cultures also plays a major role in creating a difference in the spatial configuration of Indo-Portuguese houses, as women are given utmost privacy in Indian culture, that they are secluded from the rest of the house unlike the Portuguese culture, where women are given equal rights. The ornamentations in the exterior are inspired by Islamic architecture and Portuguese culture but are made by the local artisans, using locally available materials and hence have a mix of both cultures. Thus, certain aspects of either Indian culture or Portuguese culture are either retained or altered, resulting in the creation of a new architectural style.

REFERENCES

1. Nopadon Thungsakul, A Syntactic Analysis of Spatial Configuration towards the understanding of continuity and change in Vernacular Living Space: A Case Study in the Upper NorthEast of Thailand, Dissertation, Doctor of Philosophy, University of Florida, 2001.
2. Joy Maina, Using Space Syntax methods to explore abandoned prototype housing units in Tangale Land, North-Eastern Nigeria, Journal of Space Syntax, ISSN: 2044-7507, Vol.3, Issue 2, 2012.
3. Amos Rapoport, 1969, House, Form and Culture, Published by Prentice Hall, Inc. Englewood Cliffs, NJ 07632 USA.

4. Abir Bandyopadhyay, Space Syntax – A Tool for Understanding Spatial Organisation and its changes over time, published in the proceedings of IV International Conference of International Society of Vernacular Settlements' held at Ahmedabad February 14- 17,2008.
5. Pearson M.N, The Portuguese In India, The Cambridge History of India, Cambridge University Press, 2008.
6. Pandurang R. Phaladesai, Dr.Pratima P.Kamat, A Cultural History of the Canacona taluk of Goa, Doctorate of Philosophy in History, Dept. of History, Goa University, 2003.
7. Manuel C.Teixera, Portuguese Traditional Settlements, A result of Cultural Miscegenation, TDSR Vol.I, 1990, 23-34.
8. Bill Hillier, Julienne Hanson, The Social Logic of Space, Barlett School of Architecture and Planning, University College London, Cambridge University Press, 2005.
9. Bill Hillier, Spatial Sustainability in cities: Organic Patterns and Sustainable forms, In Koch, D. and Marcus, L. and Steen, J., (eds.) Proceedings of the 7th International Space Syntax Symposium. (pp. p. 1). Royal Institute of Technology (KTH): Stockholm, Sweden. Jan 2009.
10. Rohit Nadkarni, Investigation of Built form of Fountainhas based on Socio-Cultural Aspects. Bachelor of Architecture, Goa College of Architecture, Altinho, Panaji, Goa, May 2003.
11. Michael J.Oswald, The Mathematics of Spatial Configuration: Revisiting, Revising and Critiquing Justified Plan Graph. Oswald, M.J. Nexus Netw J (2011) Vol. 13, Issue 2: pp 445 - 470. <https://doi.org/10.1007/s00004-011-0075-3>.
12. Abhijit Paul, Axial Analysis: A Syntactic Approach to Movement Network Modeling, Institute of Town Planners, India Journal 8-1, 29 – 40, March 2011

AUTHORS PROFILE



Tony Marcel Nisha, Research Scholar,
Department of Architecture, Periyar Maniammai
Institute of Science and Technology, Thanjavur, India.
Research Topic: Influence of socio-cultural components
in the spatial configuration of Indo - Portuguese houses.

Publications:

1. Tony Marcel Nisha ,Dr.P.Jayasudha, Portuguese Architecture in India – The Architectural Scenario of Manapad, an Indian Coastal Village, ICET, PeriyarManiammai University, Vallam, Indian Journal of Scientific Research, Vol.14, (1), 138-142,2017, ISSN: 2250-0138.
2. Tony Marcel Nisha ,Dr.P.Jayasudha, Kayalpatnam: A Reflection of Culture and Tradition being rooted for years. Thanima 22nd International Conference on Design Pedagogy & Contextual Aesthetics 2017, NIT CALICUT 19,20, 21 January 2017.
3. Tony Marcel Nisha ,Dr.P.Jayasudha, Sustainable Built Environment: Learning from Vernacular Settlement – A Case of Manapad, in the Coastal Stretch of Tuticorin, Indian Journal of Science and Technology. Volume 9, Issue 45, December 2016
4. Tony Marcel Nisha , Dr.P.Jayasudha, Cultural Expressions In Architecture – A Case Of Manapad In The Coastal Stretch Of Tuticorin, IOSR Journal of Mechanical and Civil Engineering (IOSR-JMCE) e-ISSN: 2278-1684,p-ISSN: 2320-334X, Volume 13, Issue 5 Ver. III (Sep. - Oct. 2016), PP 14-20.
5. Tony Marcel Nisha ,Dr.P.Jayasudha, Sustainable and Energy Efficient Design Principles in Vernacular Architecture, IJARBEST, Volume 2, Special Issue 11 – Feb. 2016.
6. Tony Marcel Nisha ,Dr.P.Jayasudha, Reflection of Climate and Culture in Architecture - Case of Tiruchendur, Tamil Nadu, Global Journal for Research Analysis. Volume-3, Issue11, Nov Special Issue -2014 • ISSN No 2277 - 8160 Research Paper.



Dr.P.Jayasudha,Professor,Department of Architecture,
Faculty of Architecture, Periyar Maniammai Institute
of Science and Technology, Thanjavur, India.

s Papers Published:

1. Jayasudha, P, Dhanasekaran, M, Monsingh D Devadas & Ramachandran, N 2013, 'Study on Sustainable Design Principles of a Vernacular Dwelling in Thanjavur Region of Tamilandu, India', (Accepted and awaiting for publication) Indian Journal of Traditional Knowledge.
2. Jayasudha, P, Monsingh D Devadas & Ramachandran, N 2011 'Proposing a rural cluster as a Sustainable Land use Model to assess the concept of Pura' in the Conference Proceedings 'Green Cities: Design, Planning And Management – ICGCDPM'

Papers presented in Conference Proceedings:

1. Jayasudha, P 2005, 'Temple Fortress Technology' in the National Level STTP organized by Tamil University, Thanjavur.
2. Jayasudha, P 2007, 'Rural Tourism', National Conference on Tourism and Architecture, Thiagarajar College of Engineering, Madurai, India.
3. Jayasudha, P, Monsingh D Devadas & Ramachandran, N 2011, 'Proposing a rural cluster as a Sustainable Land use Model to assess the concept of Pura' International Conference on Green Cities: Design, Planning And Management (ICGCDPM2011), MANIT, Bhopal, India.
4. Jayasudha, P 2012, 'Seismic Design Principles – Lessons from the Vernacular Architecture', National Programme on Capacity Building for Architects on Earthquake Risk Management (NPCBAERM), NIT, Trichy.
5. Jayasudha, P, Monsingh D Devadas & Ramachandran, N 2012, 'A study on Vernacular Settlements in Thanjavur District, Tamil Nadu, India and Assessing its Suitability in Modern Context', 5th International Congress on Environmental Research, UMT, Kuala Terengganu, Malaysia.
6. Jayasudha, P, Monsingh D Devadas & Ramachandran, N 2013, 'Understanding Sustainable Vernacular Design Principles As A Solution To Disaster Resistant Architecture', International Conference on Disaster Mitigation and Management towards Sustainable Development, Periyar Maniammai University, Vallam, Thanjavur, India.
7. Jayasudha, P, Dhanasekaran, M, 2014, 'Thermal Performance Assessment of a Vernacular Residence in Thanjavur Region' in the International Conference on Innovative Research and Solutions (ICIRS 2014) held at Pondicherry organized by JIRAS Journal and Bharath University, Chennai, April 12, 2014.