

Robotic-Wheelchair Control Head Orientation and Eye Ball Movement Control with Health Monitor System

A. Krishnamoorthy, V. Vijayarajan, R. Kannadasan, Shikhar Johari

Abstract--- Nowadays many people have lost ability to control their upper and lower parts of the body. Due to ageing and also some health issue like paralyses. In order to overcome these problem we need electrical control wheel chair instead of older joystick. Initially only the control of wheel chair mechanism is done. Which is more complex and takes more time. In order to do the automatic control of wheel chair and the body parts are done. If the person heart beat raises then the normal rate means then it is monitored and then if the body temperature of the person raises means it will be also monitored and displayed. If any condition the blood pressure of the person increases means it is monitored and displayed on LCD. In order to control the hand movement of the person the MEMS accelerometer is used and the eye blink is used to monitor the eye movement of the person. The wheel chair mechanism is controlled separately if any object come in front while operating wheel chair means then the ultrasonic sensor is used to detect that. It reduces the complexity and time and also easily operated by paralyses person's.

Keywords--- Wheel chair mechanism, Temperature sensor, Eye blink sensor, Blood pressure sensor, Ultrasonic sensor, MEMS accelerometer, Heart rate.

I. INTRODUCTION

The Robotic wheel chair mechanism extend the capabilities of older joystick. For handicapped person humans found a hand control wheel chair which is operated manually which need manpower. In order to overcome that the wheel chair mechanism is proposed which is automatically operated according to the move of disabled or aged person[1]. For monitoring the temperature and heart beat of the paralyzed person the heart beat sensor and the temperature sensor is used[2]. In order to monitor the hand movement of the person the MEMS technology is used. It is operated along with the accelerometer which will predict the hand movement of the person[3]. The survey says the heart beat rise and also blood pressure rise is the major reason for the heart attack in order to prevent that the continuous monitoring of the body parts should be done for that the heart beat sensor and blood pressure monitoring sensor is used[4]. The continuous monitoring of the body part will prevent the person who is in wheel chair from risk[5]. In wheel chair mechanism while operating it if any obstacles

comes means in order to prevent that the ultrasonic sensor is used which will predict the obstacles from the way[6].

II. BLOCK DIAGRAM

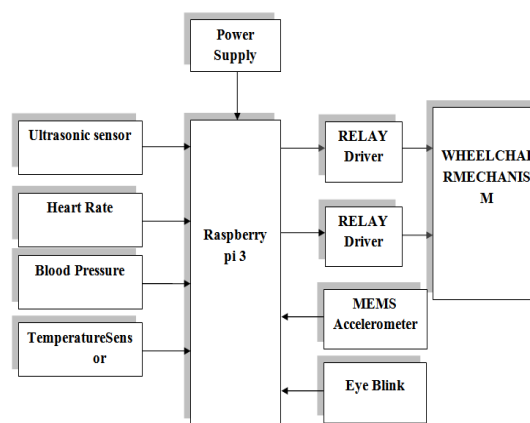

Figure 1: Block diagram of wheel chair mechanism

In the existing concept the wheel chair mechanism is used only with the temperature sensor or along with heat beat and blood pressure sensor. The main drawback in that mechanism they can only able to control the wheel chair mechanism alone and also able to monitor the blood pressure or temperature only.

In the Proposed one will can able to control the wheel chair mechanism using motor drive and also able to monitor the temperature, blood pressure, heart beat rate of the body by using the required sensors. In this process the Raspberry pi is connected with the sensors along with the MEMS technology which is controlled by accelerometer which will predict the movement of the hand of the person and then the eye blink is used to monitor the movement of the eye lashes of the person. Based upon the sensor output can predict the condition of the person and also, we can control the wheel chair mechanism direction and motion.

III. SYSTEM OVERVIEW AND RESULTS

A. Temperature sensor

In order to measure the temperature range of the place, person etc., the temperature sensor is used. If the body temperature of the person increases from the normal range to abnormal range then the LM35 sensor will detect it and display on the LCD.

Manuscript received February 01, 2019

A. Krishnamoorthy, Assistant Professor (Senior), School of Computer Science and Engineering (SCOPE), Vellore Institute of Technology, Vellore, Tamil Nadu, India.

V. Vijayarajan*, Associate Professor, School of Computer Science and Engineering (SCOPE), Vellore Institute of Technology, Vellore, Tamil Nadu, India. (e-mail: vijayarajan.v@vit.ac.in)

R. Kannadasan, Assistant Professor (Senior), School of Computer Science and Engineering (SCOPE), Vellore Institute of Technology, Vellore, Tamil Nadu, India.

Shikhar Johari, UG Student, School of Computer Science and Engineering (SCOPE), Vellore Institute of Technology, Vellore, Tamil Nadu, India.

B. Blood pressure and Heart beat

In order to measure the blood pressure and the heart beat rate the sensors are used.

If the person's heart beat is increased then it will cause severe problem in the body like heart attack. One of the major reason for heart attack is also blood pressure rise. In order to overcome the problem that we are using heart beat sensor and blood pressure sensor which will monitor it and display the condition in LCD using Raspberry pi3.

C. Ultrasonic and eye blink

In this mechanism if any object(ie. Obstacle) comes in front of the wheel chair mechanism means then the ultrasonic sensor is used to stop the mechanism and change the direction.

The eye ball of the person is monitored to check whether the person is normal or not.

D. MEMS Accelerometer

In order to monitor the movement of hand, legs, head the MEMS technology is used.

In this the MEMS technology is controlled using accelerometer which will control the hand movement of the person.

E. Wheel chair Motor

The DC motors are used for the movement of the wheel chair and the person will be sited on the wheel chair.

F. Relay Driver

The Raspberry Pi controller will not be able to drive the heavy motors so that the driver circuit is required to drive the mechanism it will provide the necessary supply to drive the motor.



Figure 2: Hardware snapshot for an Robotic-Wheelchair Control Head Orientation and Eye Ball Movement Control with Health Monitor System

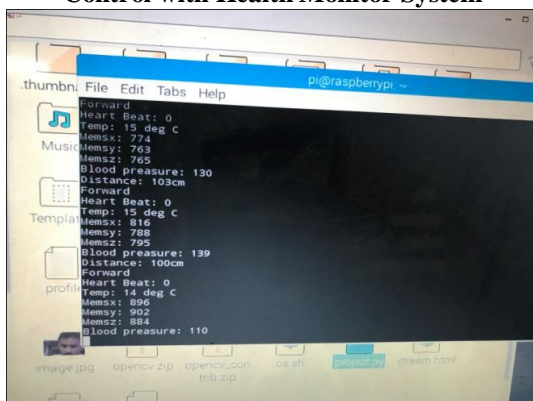

Figure 3: Hardware output snapshot for an Robotic-Wheelchair Control Head Orientation and Eye Ball Movement Control with Health Monitor System

IV. CONCLUSION

In this project we will able to control the Wheel chair mechanism using the Raspberry Pi3 controller and also the movement of the eye blink is monitored. If any obstacle comes means then it will be detected by ultrasonic sensor. The body temperature and the heart beat rate and also the blood pressure of the person is monitored b sensors. The MEMS technology along with accelerometer is used to control the hand moment of the person. By this we can able to control many sensors and also it reduces the time. The person who suffers from spinal co problem have many advantages on this process.

REFERENCES

1. Legged Mobility Legged Mobility A Wheelchair Alternative A Wheelchair Alternative Drew R. Browning John Trimble Shin-Min Song Roland Priemer Chang-de Zhang UniversityIllinois at Chicago
2. International Journal of Electrical, Electronics and Data Communication, ISSN: 2320-2084 Volume-3, Issue-6, June-2015 Patient Monitoring Smart Wheelchair patient monitoring smart wheelchair Imanpreet singh minhas, jeevanchavan, ujwal singh.
3. International Advanced Research Journal in Science, Engineering and Technology Vol. 2, Issue 6, June 2015 Copyright to IARJSETDOI10.17148/IARJSET.2015.2619 84 Head Motion Controlled Wheel Chair using MEMS
4. Robotics and Biomimetics (ROBIO), 2010 IEEE International Conference on Continuous blood pressure monitor.
5. Inventive Computation Technologies (ICICT), International Conference on Sensor networks based healthcare monitoring system Sign In or Purchase.
6. IEEE Journal on Robotics and Automation (Volume: 4, Issue: 2, Apr 1988)Obstacle avoidance with ultrasonic sensors.