

Performance of Rotating Biological Contactor for Treating Segregated Grey Water for Reuse

V. Nehru Kumar, S. Syed Enayathali

ABSTRACT:- The laboratory model of two-stage Rotating Biological Contactor (RBC) which was used in the present study is a modified one, with a provision to vary the speed of rotating blades. Grey wastewater was used to study the performance of the modified rotating biological contactor. The reactor had four rotating blades in each stage, having the size of 300 mm x 100 mm x 10 mm, attached perpendicular to the shaft. The experiment was conducted for different influent COD loads and different speeds of rotating blades. Among the different speeds of rotational blades in treating grey water, the rotational speed of 3 rpm was found to yield better percent removal of COD at 95.07% as maximum, where as against the rotational speeds of 4.5 and 6 rpm, the treatment efficiency is 95.04% and 94.96% respectively.

Keywords:- RBC, Rotating blades, Grey water, COD, OLR,

I. INTRODUCTION

Water usage in an Indian residential building is 4% for drinking, 4% for cooking, 41% for bathing, 22% for toilet flushing, and 15% for laundry; 14% for cleaning, sprinkling and other miscellaneous purpose. Wastewater segregation and treatment for reuse has become the best wastewater management option. Increasing the grey water reuse by lowering fresh water use for irrigation is an important step towards better environment and resource management. Grey water is a part of used household water which has not come into contact with toilet waste. Grey water produced can vary across each household according to the number of household occupants, ages, lifestyles, health and water use patterns. It contains waste that a household would normally wash down in drains. This content can vary between households, across different days and is dependent on daily household activities. Generally grey water contains soap, shampoo, toothpastes, cooking oils, laundry detergents, hair, and cleaning products. A physical model of rotating biological contactor (RBC) was used to study its performance for achieving desirable characteristics for reuse the treated grey water, in agriculture and landscape developments.

II. EXPERIMENTAL SET-UP

The experimental model has been designed, on the basis of empirical, as a laboratory scale RBC for an effective volume of 30 liters (In three compartments: two stages of rotating contactors and a settling tank in the third compartment). A specialty Nylon wire mesh spread on both side of all the blades to impart enhanced biofilm area. The blade rotations are arranged in the opposite direction to the liquor flow, tangentially.

Manuscript Received on May 05, 2012.

V.Nehru Kumar, Professor and Director, Centre for Environment, Health and Safety, Annamalai University, Annamalainager, Tamil Nadu, India.

S . Syed Enayathali, Ph.D. Scholar, Department of Civil Engg., Annamalai University, Annamalainager, Tamil Nadu, India.

The shafts of each stage are connected suitably to a gear motor assembly. The speed of rotating blades is 3, 4.5 and 6rpm. The schematic diagram of experimental set-up of the modified Rotating biological contactor is presented in Figure.1. The composition of the grey water is presented in Table.1.

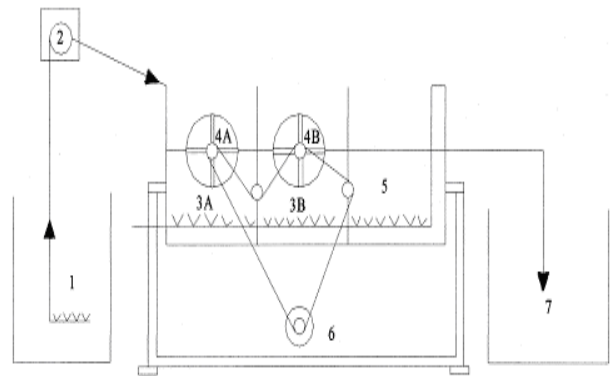

Figure-1. Schematic Diagram of Experimental Setup (RBC-105 L Capacity)

- 1. Grey water Mixing - Supply Tank
- 2. Peristaltic Pump; Miclins / 15pp
- 3A,3B - Stages of RBC
- 4A,4B - Rotating Contactors
- 5. Clarifier
- 6. Geared Motor- pulley assembly; IHP
- 7. Treated Grey water

Table .1. Typical Composition of the Grey water

Parameter	Concentration
Total Suspended solids (TSS)	100 mg/l
Chemical oxygen demand (COD)	250 mg/l
Biological oxygen demand (BOD)	100 mg/l
TKN	20 mg/l
Sodium	50 mg/l
Total Phosphorus	0.5 mg/l

III. METHODOLOGY

In the present study, a two-stage RBC followed by a settling tank was envisaged as the modified RBC. Real time grey water samples were daily collected from a residential building complex, for conducting the experiment. The raw grey water was pumped at a pre-determined rate to the model by a peristaltic pump. The model was run for five different average influent substrate concentrations measured as COD



(248,294,347,395 and 448 mg/l). Each stream was fed into the model for five different hydraulic flow rates (13.2, 10.5, 7.01, 5.3 and 4.4 l/h). Each combination of these two was conducted on three different speeds of the rotating blades (3, 4.5 and 6 rpm). In total, the experiment was conducted for 75 combinations of these three operating variables. An increase in the rotational speed shows decreased in removal percentage of COD.

IV. RESULTS AND DISCUSSION

The different rotational speeds of blades, used in this study are 3, 4.5 and 6 rpm. The rotational speed of blades was found to affect the performance of the model. An increase in the rotational speed decreases the percentage of COD removal efficiency of the model plant. The results of model performance studies are analysis are given in Table 2, 3 and 4. Among the three rotational speeds of discs namely 3, 4.5, and 6 rpm, the blade rotational speed of 3 rpm is found to give better results. The maximum COD removal was observed for 95.07% against OLR of 0.234 kg.COD/m².day, for the rotational speed of 3 rpm. The present study shows that with proper management, grey water can be used for irrigation /gardening without any risk.

V. CONCLUSION

The optimum rotational speed of the blades is understood to be the lowest possible. Though, 3 rpm of the blade rotational speed was found to be optimum from the results of the experiment, it could be still lower in the full fledged, field level RBC plants, for better removal of COD from the waste streams.

ACKNOWLEDGEMENT

The content of this article is a part of the Ph.D work carried out by S.Syed Enayathali. The authors thank the authorities of Annamalai University for their permission to do this.

REFERENCES

1. Metcalf & Eddy (2007). Wastewater Engineering treatment and reuse, Tata McGraw-Hill, 23th Edition.
2. APHA, 1995. Standard Methods for the Examination of Water and Wastewater, 17th Edition. American Public Health Association, Washington,DC,USA.
3. Friedler, E.,R.Kovalio and N.I.Galil (2005), On site Grey water Treatment and Reuse in Multi-Storey Buildings, Water science & Technology vol51 no 10 pp187-194.
4. Eriksson,E., Auffarth,K., Henze,M., and Lendin ,A.,(2002), Characteristics of Grey water , Urban water , 4, pp85-104.
5. Jeppersen, B.and Solley, D,(1994) Domestic grey water reuse :overseas practice and its applicability to Australia, Urban water research association of Australia, Melbourne.
6. Nehru Kumar, V.,(2005) Effect of speed of rotating discs in the modified RBC for treating sago wastewater , Poll.Res.24(4):823-825(2005).
7. Trivedy, R.K. and Goel.P.K (1986) Chemical and Biological methods for water pollution studies, environmental publications, Karad.