

Vibration Measurement of a Rotating Shaft using Electrostatic Sensor



Muhammad R. Jamal, Khaled S. Al Rasheed

Abstract: Measuring Vibration parameter for rotating machinery is essential for monitoring and diagnosis system in industrial plants. This paper demonstrates another approach to vibration measurement for rotating machine using electrostatic sensor and signal processing techniques. A single electrostatic sensor is used to detect charges surrounding the moving shaft of the machine. The signal from the electrostatic sensor is processed in MATLAB using Autocorrelation, Fast-Fourier, and Root Mean Square. The implementation of this technical approach was conducted on a modified test rig using three different shafts. The three shafts represent three different vibration modes: normal, abnormal, and severe. Each shaft was experimented under low and high rotation speed to observe amplitude and frequency level. Although the results of the tests did not show a direct measure of vibration displacement, due to the complex nature of the induced charges by the surface pattern. However, the results showed an indicative level of vibration at different amplitudes for the three shafts.

Keywords: Autocorrelation, Vibration, Electrostatic sensor, DSP

I. INTRODUCTION

Vibration is a key parameter measure for rotational machinery. Engineers are aware of the dangerous and consequences that critical vibration may lead. Having vibration sensors on board of the machines are very common. The most common vibration sensors available today Accelerometers and Eddy current displacement probes. However, these sensors have some limitations. Accelerometers are cheap and suitable for high-frequency range [1]. Eddy current can detect the mechanical clearance, but it is hard to install. To date, there have been some proposed techniques to measure vibration based on Laser Beam, Fibre Brag Grating, Fast Rotating field and Giant Magnetoresistance. Some technical articles proposed methodology to measure vibration of rotating shaft using electrostatic sensor. Hence, in this paper a work has been conducted to verify this methodology by using a test rig of three-cylinder shape shafts which has been modified to simulate modes of displacements as vibration. A sample data has been taken for each test to further investigate the potential of frequency behavior using offline MATLAB analysis for signal processing.

Manuscript received on August 28, 2021.

Revised Manuscript received on September 05, 2021.

Manuscript published on September 30, 2021.

*Correspondence Author

Muhammad R A A Jamal*, Member of Training Staff, Higher Institute of Energy PAAET, Kuwait.

Khaled S Al Rasheed, Senior Specialized Engineer, Department of Electrical and Electronics Engineering, Public Authority for Applied Education and Training-Higher Institute of Energy, Kuwait.

© The Authors. Published by Blue Eyes Intelligence Engineering and Sciences Publication (BEIESP). This is an [open access](https://creativecommons.org/licenses/by-nc-nd/4.0/) article under the CC-BY-NC-ND license <http://creativecommons.org/licenses/by-nc-nd/4.0/>

II. BACKGROUND HISTORY

Rotating machinery plays important roles in industrial plants. They are available as mechanical equipment such as pumps, fans, compressors, or as electrical equipment such as motors and generators. Figures 1 and 2 are examples of some of the rotating machines available in industries.

The three major parts of every rotating machine are, the rotor, the bearings, and the supporting assembly. Each of them is considered complex in design and structure. Also, the size and weight. Engineers design the rotor by the stepped cylindrical geometry, mechanical load, and stress [8]. In the other hand, bearings are specially made to minimize friction between two moving elements. The most common type of bearings used for rotating machines is the ball bearing [9]. However, they do not tend to last forever. As they wear within some period or lack of lubrication. So finally is the supporting assembly, which holds the rotor to individual axes. It keeps the rotor in the rotating machine steady in one direction of rotation.

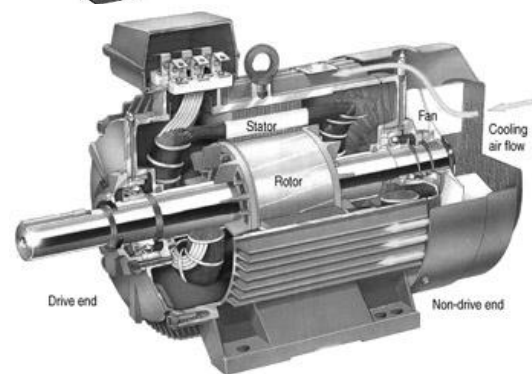
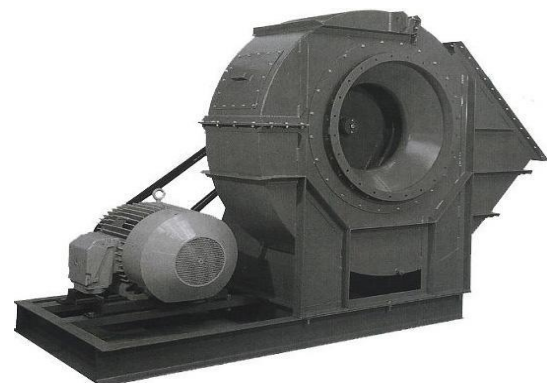

When rotational machinery is running, they produce noise and vibration. Noise is usually caused by the air pressure fluctuation surrounding the rotating shaft because of the mechanical force. The noise depends on the size and type of the machine.

Vibration Measurement of a Rotating Shaft using Electrostatic Sensor

In the other hand, vibration is a result of mechanical force and magnetic force. Mechanical power of an out-of-balance or misaligned rotary shaft may form frequent pulsations, which might increase the pulsations at higher speed. The magnetic force in electric machines also produces vibration, due to the air flux in the machine [11].

A. Vibration:

Vibration is the back-and-forth motion of an object during a period. It is the Frequency or the number of complete action cycles in one second [12]. For example, earthquakes are the most well-known vibration. A person can occasionally feel them if the magnitude of the earthquake is said to be small to medium. A classical instrument invented in 1935 by Charles Richter and Beno Gutenberg is used to measure the level of an earthquake.

III. PROBLEM STATEMENT

A. Vibration in Rotating Machines:

It is very common to notice a vibration in rotating machines. Acceptable vibrations may not cause harm for the machines for some time. However, if vibration exceeds a certain level, the machine can be at high risk. Vibration may be an indicator of such condition or fatigue. The most three common causes of vibrations in rotating machines are repeating forces, looseness, and unstable flow. Repeating forces of rotation greater speed may create lateral forces and moments due to imbalance rotor, misalign, or wear. Such forces may exceed certain vibration levels and develop the unstable condition. Furthermore, looseness is most likely to appear after maintenance period, exactly in commissioning. Machine parts are loose, such as loose bolts, mismatched parts, corrosion, and cracked structure may create excessive clearance that eventually make the machine vibrate [15].

Another cause of vibration in rotating machines is Instable Flow because of possible mechanical restrictions at the inlet or outlet. When the media is turbulent or uneven, it can affect the rotor stability. For example, compressors are usually hardly to vibrate at full load. Because of airflow are evenly distrusted at high speed. However, when load is reduced to half, a bigger chance of twisted airflow occurs, which leads to an increase of vibration level [16].

Vibration in rotating machines may occur in three different directions. Knowing that rotors move axially, logically the first type is in the axial direction. Axial vibration is most common in jet engines. Thrust in the axial direction. The second type is Lateral vibration; it is also called Transverse or Flexural vibration. Also, it is most likely to appear on high-speed machines. However, considering the natural frequencies from the stiffness and mass distribution of the machine in the design stage, vibration can be minimized.

B. Existing vibration measurement and limitations:

To date, various methods have been developed and introduced to measure vibration in rotating machines. Industries have been using vibration sensors in rotating machines for som many years. The most popular one and considered simplest than others is the Accelerometer sensor. Accelerometers measure acceleration forces by Piezoelectric transducer. Piezoelectric transducer is a device that converts mechanical stress into an electric signal. Accelerometers are simple, accurate and responsive at high frequency [27]. It usually mounted on the machine casing. It is a contact type vibration transducer. However, accelerometers do not

measure the vibration directly acting on the rotating shaft, and it is best used to describe the bearing fatigue and casing resonance.

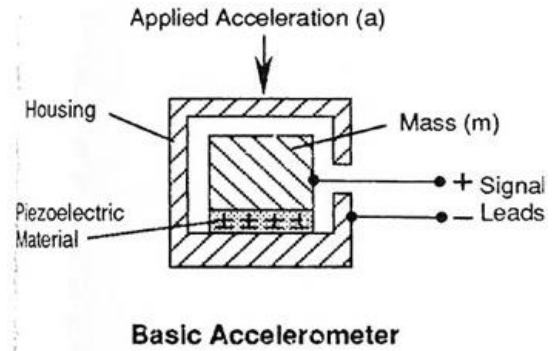

Figure 1. Basic Accelerometer [28]



Figure 2. Photo of Accelerometer Sensor [29]

Another famous sensor type for vibration measurement in rotating machines is based on the Displacement method. Eddy current Proximity Probes are used to measure the displacement of a rotating element through Magnetic Field. Alternating magnetic field is generated by the internal electronic circuit toward the object being sensed as seen in figure 11. The induced Eddy current on the sensing object resists the field by the probe creating an output voltage. The signal voltage depends on the displacement or distance from the tip of the probe to the surface being measured. This method used for detecting misaligned or imbalance rotor. The probes are considered non-contact type transducers that do not require touching the rotating element. Figure 12 shows some examples of commercial Proximity Probes. They are small in size, relatively low cost and maintenance free. Nevertheless, they are so difficult to install, confined at a high frequency and sensitive to mechanical and electrical noise.

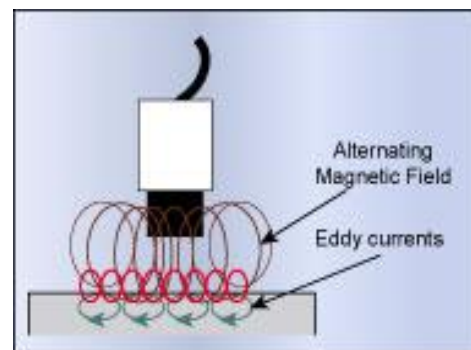

Figure 3. Magnetic field of Proximity Sensor [30]



Figure 4. Different sizes of Proximity Sensor [31]

A state of the art vibration sensors based on Laser-Doppler (LD) technology [32] inspired by the science of Metrology [33] has been around for few years. Laser Doppler Vibrometer and Laser Doppler Velocimeter (LDV) are different from the traditional accelerometers in some respects. LDVs are considered a non-invasive type of vibration measurement; no calibration is required and has full frequency range. They use a laser beam deflection method to detect angular velocity and displacement of a rotating element as seen in figure 13. A fiber optic is utilized to transfer laser power to the head of the sensor. Moreover, digital decoding technique is used to translate the bounced laser to an electrical signal. LDVs are usually used for measuring Torsional Vibration in rotating machines [34]. They are very expensive equipment and still have some limitations [35].

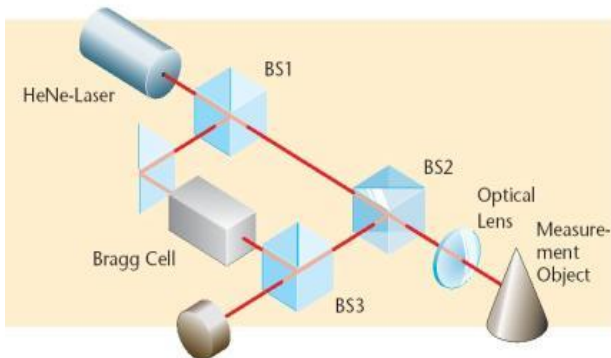

Figure 5. Beam Deflection Method for LDV Sensor [36]

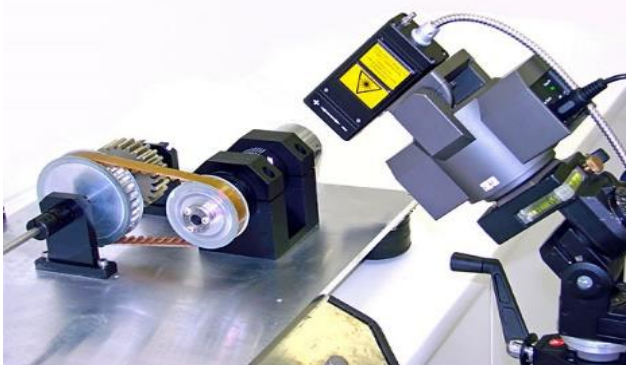

Figure 6. Photo of LDV Sensor [37]

IV.OBJECTIVE

Most industries are looking for sensors that have high accuracy, less cost, easy to install and rigid. The most common types of vibration sensors like Accelerometers and Proximity probes fit into those categories but still they have

limitations. In the other hand, LDV's are state of the art technology based on laser beam but still mature and very costly. However, a novel measurement technique of vibration measurement for the rotating element was indicated in recent research by using Electrostatic Sensor and signal processing techniques. The purpose of this project was to go a step ahead to assess the measurement technique because the electrostatic sensor could be the next best cost-effective solution of measuring vibration for rotating machinery.

A. Technical Approach:

The electrostatic sensor is based on the phenomena of electrostatic charges. Electrode with a preamplifier circuit is used [41] to attract charges that are surrounding the moving rotary due to constant friction with the air. The electrostatic sensor has many advantages over other common sensors. They are easy to build, non-contact, suitable for the hostile environment and cheap.

For this project, a single electrode rectangular shape was used [49]. The basic structure of the electrostatic sensor is made from an insulated electrode embedded into a PCB. A basic structure of the electrostatic can be seen in figure 7.



Figure 7. Basic structure of the electrostatic sensor [49]

The technical approach of this project is based on a sensing element, signal conditioning, and signal processing [49]. A physical phenomenon appears when a moving shaft is rotating on its axial. It generates charges on its surface due to friction with the air. The induced charges are highly dependent on the surface type, electrode area and distance from the shaft [41]. Due to the complex nature of physics between the surface material and the charges around the shaft, the quantity of the induced charges is hardly expected or calculated. An electrostatic sensor sits just a couple mm away from the shaft to detect the induced charges, using the attached pre-amplifier circuit as seen in figure 8. Where D is the distance between the shaft and the tip of the sensor. Meanwhile, using existing signal conditioning unit in the instrumentation lab at the University of Kent [49] to amplify and filter the signal. This technical approach focuses more on the amplitude of the signal related from the distance between the shaft and the sensing unit. Therefore, three different modified shafts to be tested to assess the vibration measurement, details of the shaft design will be further discussed in the Implementation chapter. Because vibration occurs vertically or horizontally due to mechanical issues such as bearings wear, or unbalance shaft the shaft gets closer and away from the sensing units frequently. Hence, those modified shafts will simulate a displacement like vibration.

Vibration Measurement of a Rotating Shaft using Electrostatic Sensor

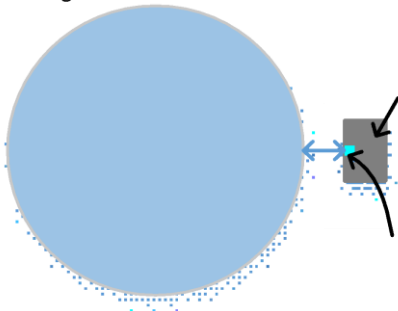

Figure 8. Measurement Setup

The signal is then digitally processed using a software signal processing such as MATLAB. This software is used to perform several tasks such as sampling and Nyquist, Fast Fourier Transform (FFT), Autocorrelation and Root Mean Square (RMS). Then, the RMS can be obtained using Equation 1 [46] to find the relative displacement.

$$\text{RMS}_i = \frac{1}{N} \sum_{j=1}^N S_{ij}^2$$

Equation 1 Root Mean Square

Where S_{ij} ($i = 1, 2, 3, 4; j = 1, 2, 3, \dots, N$) is the digital signal, i represents the number (i^{th}) of discrete signal, and N is the number of sampling points.

B. Signal Processing:

This part of the project was mainly for signal analysis. Using MATLAB, a programmable computer software that can perform digital signal processing by using loops, functions, math, arithmetic operation, and plots. The MATLAB code was put together to process the signal by using several signal processing techniques. Such as Sampling and Nyquist, Auto Correlation (to assess the signal) Fast Fourier Analysis (FFT) and calculate for RMS.

V. RESULT VIEW

A. Test Setup:

The existing Test Rig in the instrumentation lab [49] which has been used to experiment speed of shaft rotation has been utilized to conduct this project objective. The test rig in figure 9 consists of AC motor with drive control unit to adjust the speed of the motor, a driven shaft, a single electrostatic sensor, and some couplings.

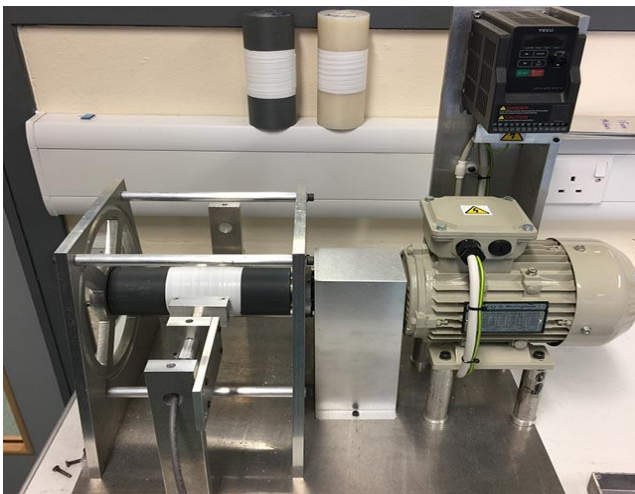

Figure 9. Test Rig used to conduct the experiment [49]



Figure 10. Closer look (top view) of the shaft and sensor

A. Shafts modification for vibration simulation:

One of the most challenges tasks in this project was to simulate the displacement of vibration on the shaft, which required a mechanical experience and physics background. The simulation was to take place using the existing Test Rig, which was designed and built for high-speed measurement. In other word, the rig is designed NOT to produce vibration at all. Making the rig shaft to vibrate might lead to damage the mechanical components. Therefore, a simple and affordable solution was needed to overcome this problem, especially during the short time given.

Initially, a simple idea was introduced to modify an existing shaft. By making the inner whole of the shaft a little bigger than the driven shaft, hence, creating a wobble effect. However, the results were not satisfactory due to the unpredictable wobbling direction of the shaft.

After few attempts, a final approach was made. Three different shafts, as seen in figure 11 and 13, were modified to simulate three types of vibration conditions. Shaft A has been amended to simulate a normal vibration condition, shaft B, on the other hand, was altered to simulate abnormal vibration condition. Moreover, finally shaft C was meant to simulate a high level of vibration condition. The idea was to make shaft A full circle cylinder to simulate normal condition as it rotates. For shaft B, the shape is a bit modified by adding a small part on one side of the shaft to simulate an elliptical shape as it rotates, as seen in figure 13. As for shaft C, the added part was made even thicker to simulate more effect of elliptical shape, hence, displacement like vibration.

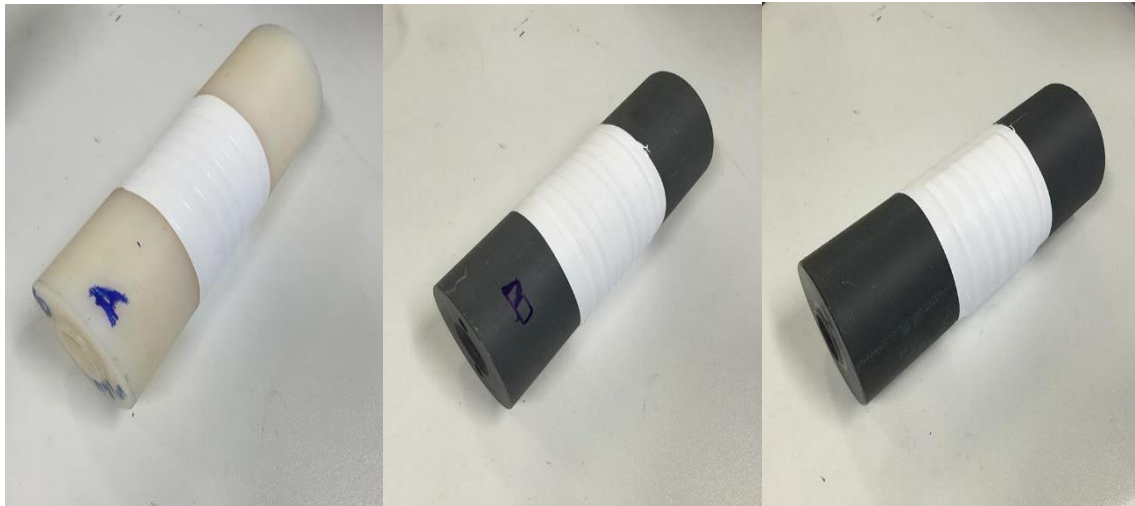

Figure 11. Photos of shafts A, B, and C



Figure 12. Angle view photos of shaft A, B, and C

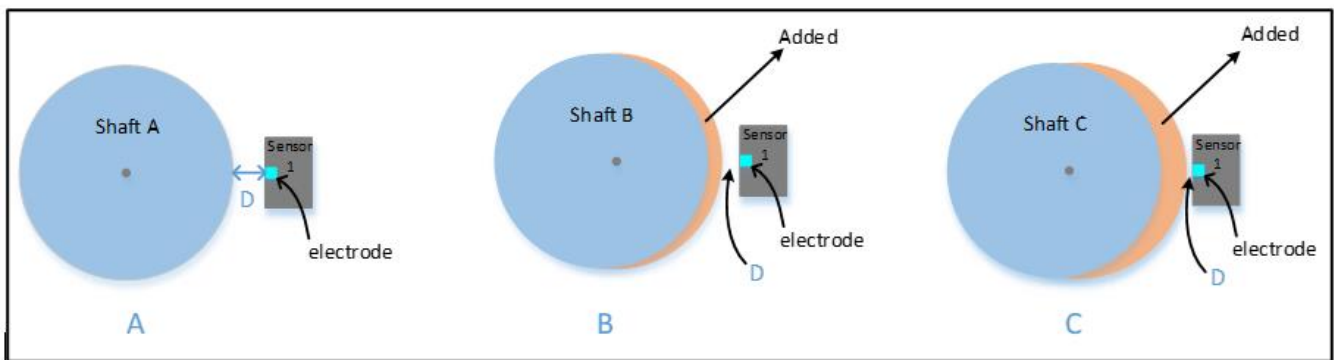

Figure 13. Layout shape of shafts A, B, and C

B. Results:

Three tests were conducted under the same setup and environment condition. Each shaft went through three tests to check repeatability at a different speed. The speeds at which the experiments made were 500, 1000, 1500 and 2000 RPMs. The results of the tests for each shaft have very similar trends. Except one in shaft A that was probably a human error. Figure 13 illustrate the RMS values for each shaft at a different speed. The RMS results were dramatically increasing from shaft A to C. This is an indicative of the relative displacement effect due to the physical shapes especially shafts B and C. Another interesting point was the slope of each shaft line as it is steeper in shaft B and C respectively. This might indicate the potential of the vibration condition.

Vibration Measurement of a Rotating Shaft using Electrostatic Sensor

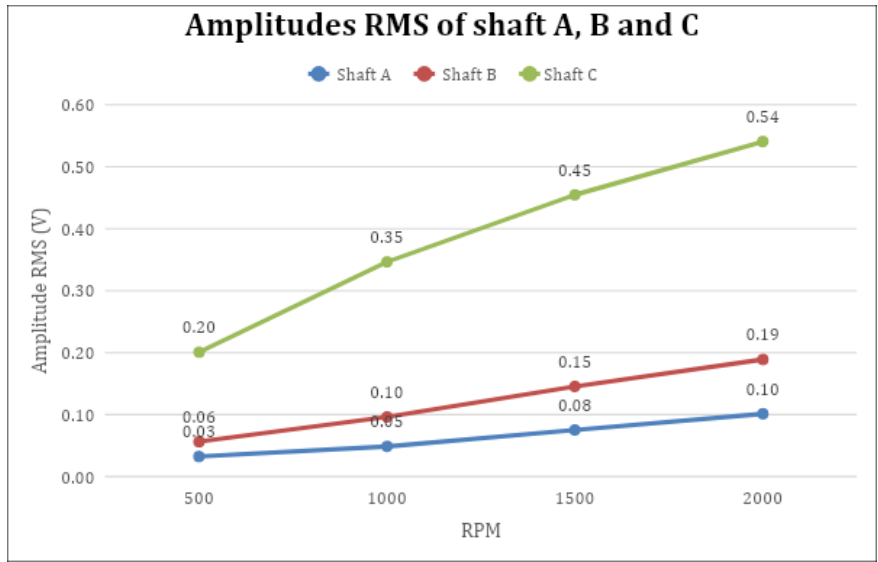

Figure 13. RMS values of shafts A, B, and C

The signals obtained at each speed was initially assessed using the Autocorrelation Function at a different speed. Figure 14 shows the plot of the Autocorrelation Function at speed 500 RPM. For example, the time delay that took the shaft to rotate was 0.1244 ms, since $RPM = (60/Time\ delay)$ then 60 divide by that delay gives almost 500 RPM, which is correct. The correlation at higher speed was also performed as seen in figure 15. However, the results of the Autocorrelation at lower and higher speed indicated that the speed of the shaft rotation can be obtained even at different shaft conditions.

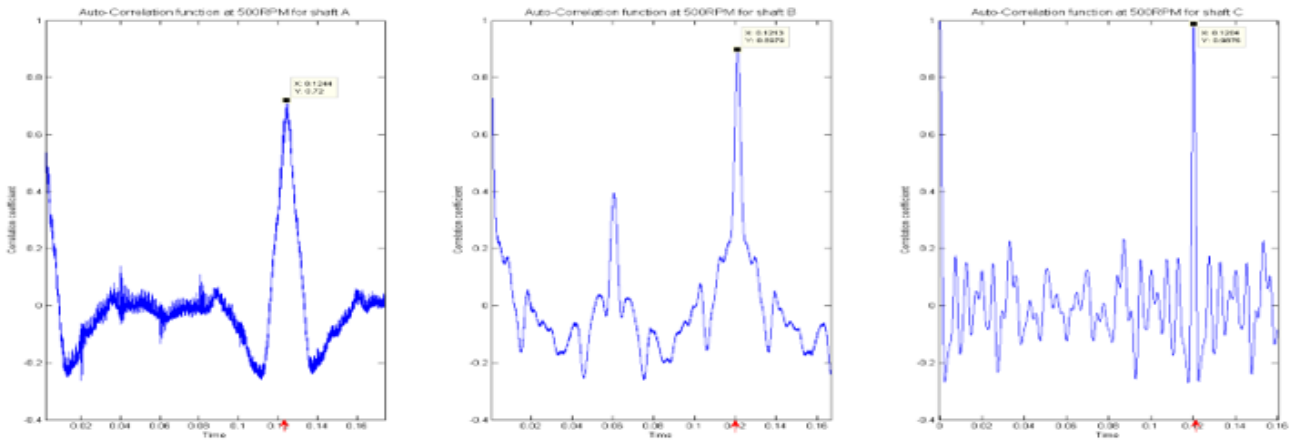

Figure 14. Autocorrelation Function for shaft A to C at 500 RPM

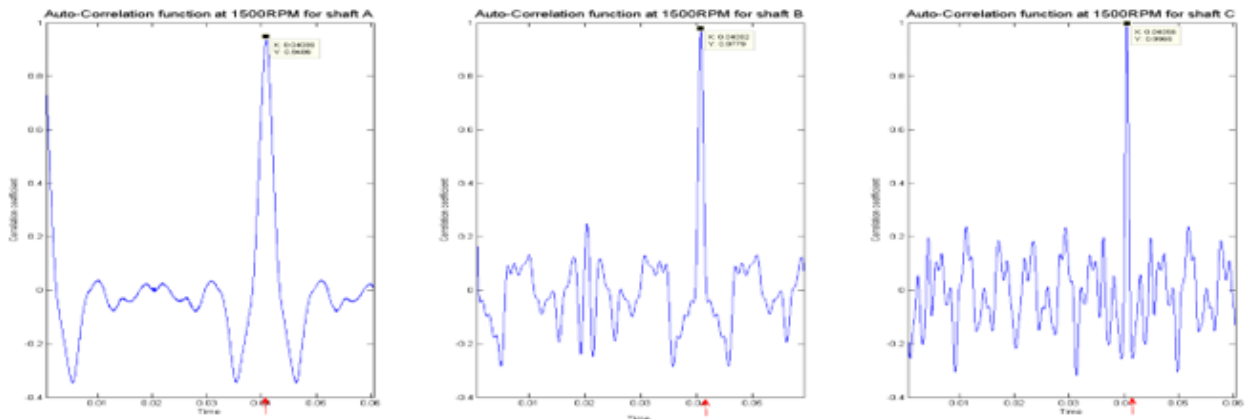

Figure 15. Autocorrelation Function for shaft A to C at 1500 RPM

Time signal analysis was performed using MATLAB. The tests were performed under several speeds 500, 1000, 1500 and 2000 RPM. To illustration, one plot was demonstrated. A periodic signal for each shaft can be noticed under low and high speed.

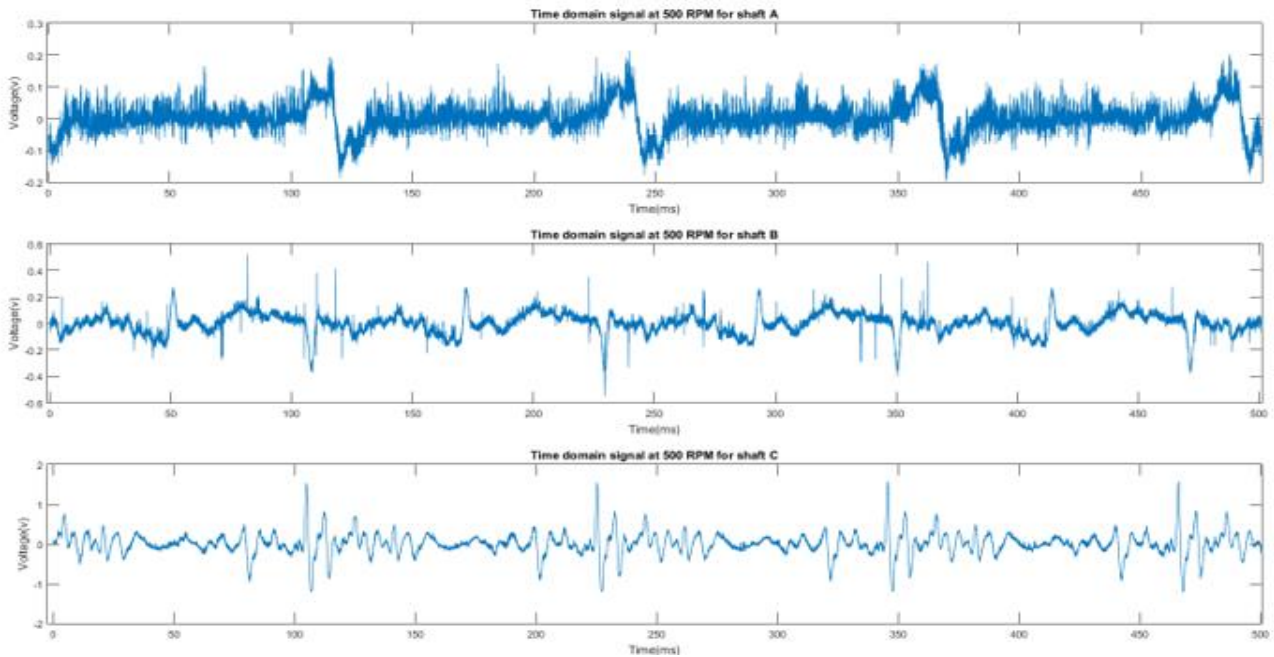

Figure 16. Time domain plots of Shafts A, B, and C at 500 RPM

The first thing that can be noticed from both figures is that all the signals are periodic because of the repeating cycle of the rotation. Also, the pulses were quite tricky. The signals amplitudes at lower speed are noticeably lower than at high speed, because of the speed difference. An interesting point that can be seen in the 1500 RPM speed is that in shaft A, the lower amplitude of the negative pulse is almost half of the positive pulse. This can also be noticed in shaft C signal but not in shaft B signal, which was hard to explain. The only thing that was certain about was that the three shafts' surfaces had different uneven and had an exotic pattern signature that produced such a complex random signal. Again, by using MATLAB to perform the Fast-Fourier-Transform to obtain the frequency domain of those three

signals. By doing so, it is possible to observe the frequency behavior of the system.

Figure 17 shows the FFT of the same signals. In fact, the results of the FFT were not anticipated. There were no distinctive frequency components that would indicate a clear vibration mode for any of the shafts. In fact, the results are neither can be expected or calculated due to the complex physics behind the distribution of the induced charges on the shaft surface. However, in shaft A the energy was mainly distributed at lower frequency components in the range from 0 to 400 Hz. In fact, when the shaft condition became more vibrant or elliptical shape, there is a significant increase in higher frequency components over 400 Hz up to 1400 Hz. This frequency distribution is indicative of how much vibration level in shaft B and C.

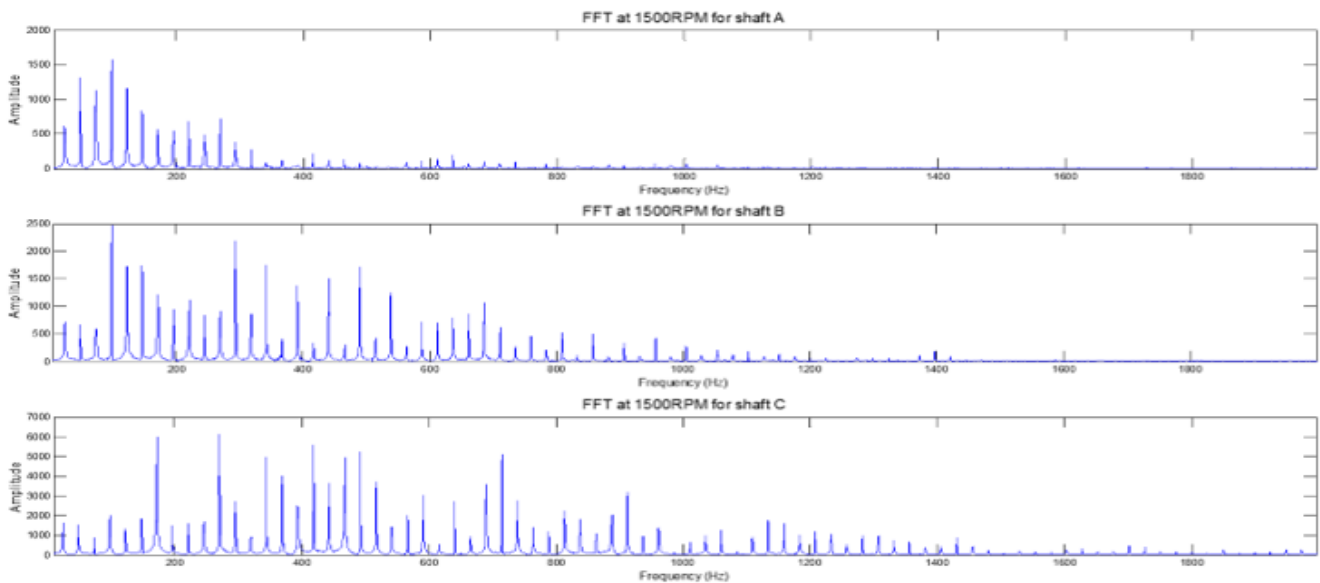

Figure 17. Frequency spectra of shafts A, B and C

Vibration Measurement of a Rotating Shaft using Electrostatic Sensor

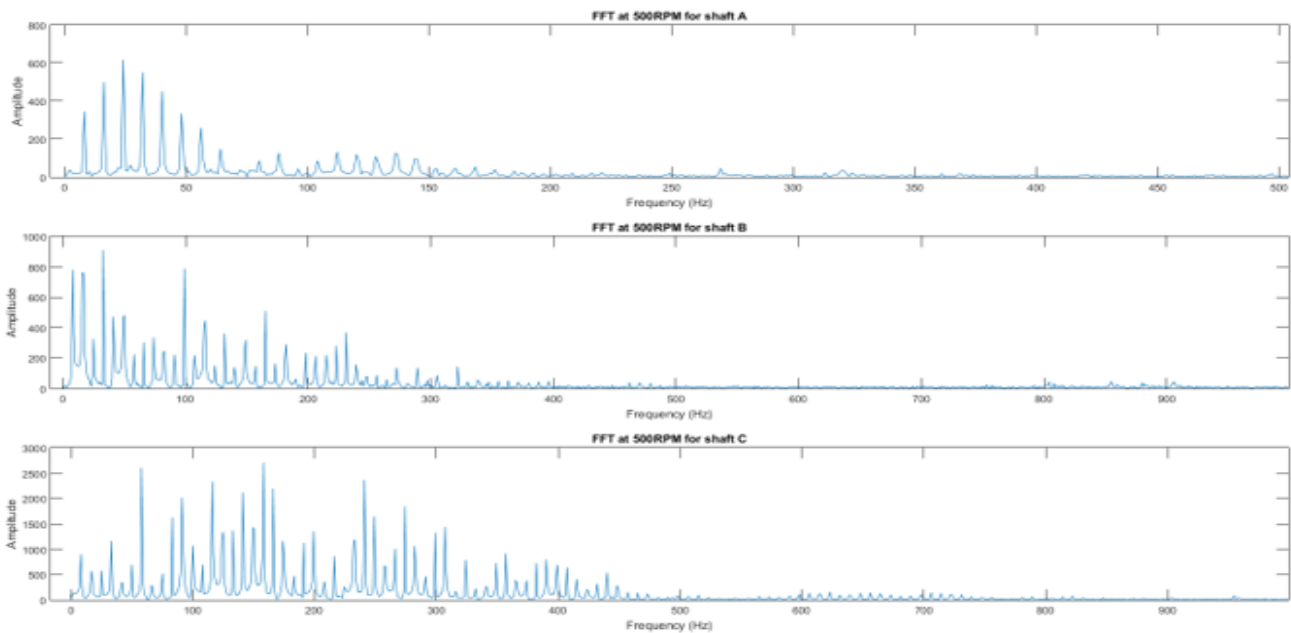

Figure 18. Frequency spectra of shafts A, B, and C

VI. CONCLUSION

The experiments made on the Test Rig [49] to assess the relative displacement vibration of the three modified shafts has been quite a challenge. The plot of the RMS values of shaft B and C were significantly increasing. Moreover, the plots of the frequency spectra were evident of how big the energy distribution of each shaft were. Although the results show an indication of relative displacement not directly. That is because of some other factors affected the results. The complex nature of the distribution of the charges during shaft rotating relies on the material and pattern of the shaft surface. Also, the electrode component of the electrostatic sensor is exposed to air. That might have the sensor to pick up unwanted noise from the surrounding environment such as humidity or the quantity of air particle.

The experiments can be improved if a dedicated and specially designed electrostatic sensor and Test Rig is made for different vibration mode conditions. A different electrodes shaped area can be tested to assess which shape gives a better result e.g., narrow, or wide. The use of multiple electrostatic sensors and a higher specs of Data Acquisition can tell us about more information on the condition of the vibration.

ACKNOWLEDGMENTS

I would like to express my gratitude and appreciation to the School of Engineering at the University of Kent, Canterbury, UK, for granting me the chance to use their instrumentation lab and test equipment in the Jennison building to conduct this experiment. Special thanks to Professor Yong Yan, Dr. Gang Lu, Dr. Peter Lee and Dr. Lijuan Wang for their valuable guidance.

REFERENCE

1. C. M. Harris and A. G. Piersol, "Harris's shock and vibration handbook," in *Ch 16*, 5th ed. Anonymous New York: McGraw-Hill, 2002, .
2. (). *Rotor shaft for aircraft engines*, DOA: 22/2/2015 [Rotor shaft]. Available: <http://www.cccme.org.cn/products/detail-3060739.aspx>.
3. (). *Forged Rotor Shaft for Steam Turbine*, DOA 22/2/2015 [Steam Turbine shaft]. Available:

http://www.weiku.com/products/15466195/forged_turbine_rotor_shaft.html.

4. Michael I. Friswell, John E. T. Penny, Seamus D. Garvey and Arthur W. Lees. "Introduction," in *Dynamics of Rotating Machines* Anonymous 2010, Available: <http://dx.doi.org/10.1017/CBO9780511780509.002>.
5. (). *Steam Turbines*. Available: <http://www.explainthatstuff.com/steam-turbines.html>.
6. (). *Forced Draft Fan*, DOA: 21/2/2015 [FD Fan]. Available: <http://windpowersystem.com.my/Products.php>.
7. (). *Structure of Electrical Machines*, DOA: 23/2/2015 [Electrical Machine]. Available: <http://www.globalspec.com/reference/57800/203279/2-4-structure-of-electrical-machines-and-their-types>.
8. S.G. Kolgiri, Sudarshan D Martande, Nitin S Motgi, "Stress Analysis for Rotor Shaft of Electric Motor," vol. 2, 2013.
9. P. R. N. Childs. "Chapter 4 - machine elements," in *Mechanical Design Engineering Handbook*, P. R. N. Childs, Ed. 2014, . DOI: <http://dx.doi.org.chain.kent.ac.uk/10.1016/B978-0-08-097759-1.00004-6>.
10. P. R. N. Childs. "Chapter 6 - rolling element bearings," in *Mechanical Design Engineering Handbook*, P. R. N. Childs, Ed. 2014, . DOI: <http://dx.doi.org.chain.kent.ac.uk/10.1016/B978-0-08-097759-1.00006-X>.
11. A. J. Ellison and C. J. Moore. Acoustic noise and vibration of rotating electric machines. *Electrical Engineers, Proceedings of the Institution Of 115(11)*, pp. 1633-1640. 1968. . DOI: 10.1049/piee.1968.0284.
12. R. K. Mobley. "Chapter 3 - vibration analysis overview," in *Vibration Fundamentals*, R. K. Mobley, Ed. 1999, . DOI: <http://dx.doi.org.chain.kent.ac.uk/10.1016/B978-075067150-7/50039-2>.
13. (). *Seismograph and Richter Scale*, DOA: 25/2/2015 [Earthquakes]. Available: <http://science.howstuffworks.com/environmental/earth/geophysics/question142.htm>.
14. (). *Seismograph illustration*, DOA: 22/2/2015. Available: <http://media.web.britannica.com/eb-media/62/168062-004-E52A6FF4.jpg>.
15. Commtest Instruments Ltd, *Beginner's Guide to Machine Vibration*. New Zealand: 2006.
16. R. K. Mobley. "Chapter 4 - vibration sources," in *Vibration Fundamentals*, R. K. Mobley, Ed. 1999, . DOI: <http://dx.doi.org.chain.kent.ac.uk/10.1016/B978-075067150-7/50040-9>. 31

17. C. Ciandrini, M. Gallieri, A. Giantomassi, G. Ippoliti and S. Longhi. Fault detection and prognosis methods for a monitoring system of rotating electrical machines. 2010, . DOI: 10.1109/ISIE.2010.5637762.
18. S. A. Ansari and R. Baig. A PC-based vibration analyzer for condition monitoring of process machinery. *Instrumentation and Measurement, IEEE Transactions On* 47(2), pp. 378-383. 1998. . DOI: 10.1109/19.744177.
19. I. Atoui, H. Meradi, B. Boulkroune, R. Saidi and A. Grid. Fault detection and diagnosis in rotating machinery by vibration monitoring using FFT and wavelet techniques. 2013, . DOI: 10.1109/WoSSPA.2013.6602399.
20. T. L. Jarrett. Computerized vibration analysis-the leading predictive maintenance tool. Presented at Pulp and Paper Industry Technical Conference, 1992., Conference Record of 1992 Annual. 1992, . DOI: 10.1109/PAPCON.1992.186301.
21. H. Seidel, B. Harazin, K. Pavlas, C. Sroka, J. Richter, R. Bläthner, U. Erdmann, J. Grzesik, B. Hinz and R. Rothe. Isolated and combined effects of prolonged exposures to noise and whole-body vibration on hearing, vision and strain. *Int. Arch. Occup. Environ. Health* 61(1-2), pp. 95-106. 1988. Available: <http://dx.doi.org/10.1007/BF00381613>. DOI: 10.1007/BF00381613.
22. V. Siskova and M. Juricka. The effect of sound on job performance. Presented at Industrial Engineering and Engineering Management (IEEM), 2013 IEEE International Conference On. 2013, . DOI: 10.1109/IEEM.2013.6962696.
23. (). *Fatal Failures: Siberia's hydro disaster*. Available: <http://eandt.theiet.org/magazine/2011/07/siberia-hydro-disaster.cfm>.
24. (). *The Catastrophic accident at the Siberian hydro plant*. Available: <http://eandt.theiet.org/magazine/2011/07/siberia-hydro-disaster.cfm>.
25. (). *Automatic Vibratoin Analysis and Conditoin Monitoring systems COMPACS [Automatic Vibratoin Analysis]*. Available: <http://www.dynamicsru.com/products/compacs-m/>.
26. (). *Stationary condition diagnostics and monitoring system, DOA: 26/2/2015*. Available: <http://www.vibrotek.com/article.php?article=articles/newgen/index.htm>.
27. (). *Piezoelectric Accelerometer*. Available: http://www.pcb.com/TechSupport/Tech_Accel.aspx.
28. (). *Basic Accelerometer DOA: 11/9/2015*. Available: <http://www.intertechnology.com/Kistler/indexAcceleration.htm>.
29. (). *Basic Accelerometer, DOA: 11/9/2015*. Available: http://www.industrial-electronics.com/DAQ/industrial_electronics/input_devices_sensors_transducers_transmitters_measurement/Accelerometers.html.
30. (). *Proximity Sensor, Eddy Current Probe, DOA 11/9/2015*. Available: <http://www.lionprecision.com/eddy-current-sensors/>.
31. (). *Photo of different sizes of Eddy Current type proximity sensors, DOA: 11/9/2015*. Available: http://www.globalspec.com/learnmore/sensors_transducers_detectors/proximity_presence_sensing/eddy_current_proximity_sensors.
32. (). *Working Principle of LDV*. Available: <http://www.polytec.com/se/solutions/vibration-measurement/basic-principles-of-vibrometry/>.
33. H. Schwenke, U. Neuschaefer-Rube, T. Pfeifer and H. Kunzmann. Optical methods for dimensional metrology in production engineering. *CIRP Ann. Manuf. Technol.* 51(2), pp. 685-699. 2002. . DOI: [http://dx.doi.org.chain.kent.ac.uk/10.1016/S0007-8506\(07\)61707-7](http://dx.doi.org.chain.kent.ac.uk/10.1016/S0007-8506(07)61707-7).
34. L. Xiang, S. Yang and C. Gan. Torsional vibration measurements on rotating shaft system using laser doppler vibrometer. *Optics and Lasers in Engineering* 50(11), pp. 1596-1601. 2012. . DOI: <http://dx.doi.org/10.1016/j.optlaseng.2012.05.018>.
35. M Johansmann, G. Siegmnd, M. Pineda, "Targeting the limits of laser Doppler Vibrometry," 2005.
36. (). *Laser Deflection method, DOA 11/9/2015*. Available: <http://www-cs.cuny.cuny.edu/~zhu/LDV/FinalReportsHTML/CCNY-LDV-Tech-Report-html.htm>.
37. (). *LDV Sensor , DOA 11/9/2015*. Available: http://acoutronic.se/images/vibration/Polytec_picture_RSV-150.png.
38. L. Wei, Z. Zhou, J. Huang and Y. Tan. FBG-based non-contact vibration measurement and experimental study. *International Journal of Precision Engineering and Manufacturing* 14(9), pp. 1577-1581. 2013. Available: <http://dx.doi.org/10.1007/s12541-013-0213-9>. DOI: 10.1007/s12541-013-0213-9.
39. S. J. Arif, S. H. Laskar and I. Imdadullah. Measurement of machine vibrations by using a fast rotating magnetic field. 2011, . DOI: 10.1109/MSPCT.2011.6150496.
40. J. Pelegri, J. Alberola, R. Lajara and J. Santiso. Vibration detector based on GMR sensors. 2007, . DOI: 10.1109/IMTC.2007.379261.
41. L. Wang, Y. Yan, Y. Hu and X. Qian. Rotational speed measurement using single and dual electrostatic sensors. *Sensors Journal, IEEE* 15(3), pp. 1784-1793. 2015. . DOI: 10.1109/JSEN.2014.2368091.
42. L. Wang, Y. Yan, Y. Hu and X. Qian. Rotational speed measurement through electrostatic sensing and correlation signal processing. *Instrumentation and Measurement, IEEE Transactions On* 63(5), pp. 1190-1199. 2014. . DOI: 10.1109/TIM.2013.2292283.
43. T. J. Harvey, R. J. K. Wood and H. E. G. Powrie. Electrostatic wear monitoring of rolling element bearings. *Wear* 263(7-12), pp. 1492-1501. 2007. . DOI: <http://dx.doi.org/10.1016/j.wear.2006.12.073>.
44. J. Q. Zhang and Y. Yan. On-line continuous measurement of particle size using electrostatic sensors. *Powder Technol* 135-136(0), pp. 164-168. 2003.. DOI: <http://dx.doi.org/10.1016/j.powtec.2003.08.012>.
45. L. Wang, Y. Yan, Y. Hu and X. Qian. Rotational speed measurement using electrostatic sensors and correlation signal processing techniques. 2013, . DOI: 10.1109/I2MTC.2013.6555413.
46. L. Wang, Y. Yan, Y. Hu and X. Qian. Intelligent condition monitoring of rotating machinery through electrostatic sensing and signal analysis. 2013, . DOI: 10.1109/ICSIMA.2013.6717951. 33
47. Y. Y. Lijuan Wang and. Mathematical modelling and experimental validation of electrostatic sensors for rotational speed measurement. *Measurement Science and Technology* 25(11), pp. 115101. 2014. Available: <http://stacks.iop.org/0957-0233/25/i=11/a=115101>.
48. Lijuan Wang, Yong Yan, Yonghui Hu and Xiangchen Qian. Performance assessment of the rotational speed measurement system based on a single electrostatic sensor. Presented at Instrumentation and Measurement Technology Conference (I2MTC) Proceedings, 2014 IEEE International. 2014., DOI: 10.1109/I2MTC.2014.6860718.
49. Muhammad Jamal, MSc Project Report "Vibration monitoring of Rotating machinery using electrostatic sensors" MSc Embedded Systems and Instrumentation, School of Engineering, University of Kent, Canterbury, Kent CT2 7NT, UK, 2015.

AUTHOR PROFILE



Khaled S Al Rasheed, (B.Sc.Eng 1998-MS 2010, PHD 2021), is currently an Senior specialized engineer at Public Authority for Applied Education and Training-Higher Institute of Energy(HIE)-Electrical Power Department (PAAET). He received B. Eng. (V Good) in Electrical and Electronics Engineering from New Mexico State University (USA), and later received MSc from University of Mansour Egypt in Electrical Engineering. He was later Leadership at HIE-Students Affairs (2012-2016), then a Leadership at HIE-Training Committee, and Adviser in the scientific club in Kuwait (Since 2008). PHD in Islamic International University of Malaysia. Interest in Renewable Energy (solar), Power Electronics.



Muhammad R A A Jamal, B. Sc. in Electrical Engineering 2002, University of Wisconsin-Milwaukee USA. M.Sc. in Embedded Systems and Instrumentations 2015, University of Kent, UK. Spent 6 years in the instrumentation and control engineering at Doha Power Station, Kuwait. Currently member of training staff in the Higher Institute of Energy PAAET, Kuwait, since 2008. Dedicated in industrial automation and sensors. Worked as embedded system consultant in prototypes development.